



— OPEN·HONEST·CONSCIENTIOUS·FAST·PROMISE —

Open Group Holding Ltd

TEMPERATURE CONTROLLER

Open Group Holding Ltd

Address: OPEN Building, Liunan Industrial Zone, Liushi Town, Yueqing
City, Wenzhou City, China

Post Code: 325619

TEL: 0086-577-6262 1999

FAX: 0086-577-6273 2105

E-mail: sales@opengroup.cc global-sales@opengroup.cc
salesdirector@opengroup.cc

- <http://www.cn-opengroup.com>
- <http://mcb.en.alibaba.com/>



Company Profile



OPEN GROUP HOLDING LTD. is located in Liushi, Wenzhou, Zhejiang Province, China. It faces the 104 National Highway that run-through Zheming Economic Zone, close to Qili Harbor and Wenzhou Airport on the south, close to the scenic spot Yandang Mountain on the north.

Quality assurance and customer satisfaction lead Open Group's top belief. OPEN GROUP HOLDING LTD. is one of the most professional manufacturers producing low-voltage and high-voltage electrical products, power equipment, cables & wires, etc. Through last 10 years' development, OPEN GROUP HOLDING LTD. has grown up as one of the biggest group companies in China, and the products range includes lightings, and lamp. We have over fifty member factories for the products above, and our products include 1,500 series and more than 15,000 industrial components.

We have precious experiences in exporting our products to the Southeast Asian, Australian, European and the American markets. Our products are well-known greatly due to high quality and reasonable price. After more than 10 years' promotion and service in the world, our products are enjoying a great share in the international market.

To present our customer more considerate service, OPEN GROUP HOLDING LTD. has modernized our production equipment, enhanced production technology and management mode. To form designing, producing, quality checking, selling as an organic whole, from quality control of the input of the raw materials and feedback of the after-sale service, etc., we have introduced TQM and other advanced producing methods to ensure the interest of our customers.

The 21st century is the era of the knowledge economy, full of the fierce competitions of technology and managing mode, but meanwhile, we can tell that there are also so many opportunities to get mutual benefits. Welcome domestic and international friends to cooperate cordially with OPEN GROUP HOLDING LTD. We believe with our best efforts, we can create the prosperity and development for both of our business.



Contents

02	KTO 011/KTS 011 (Compact Thermostat)
04	FTO 011/ FTS 011 (Tamperproof Thermostats)
06	ZR 011 (Dual Thermostat)
08	MFR 012 (Mechanical Hygostat)
10	MT01 (Mechanical Thermostat)
11	MT02 (Fan coil mechanism thermostat)
12	MT05 (Heating mechanical thermostat)
13	MT06 (fan coil mechanical temperature controller)
14	MT07 (Heating mechanical Thermostat)
15	MT08 (Fan coil mechanical thermostat)
16	ET03 (Electronic Thermostat)
17	ET05 (Mechanical Thermostat)
18	FS60/FS30 (Fan three gear speed switch)
19	SMT (Smart Constant Thermostats)
20	DC40/HT40 (LCD thermostat)
21	DC5/HT50 (LCD thermostat)
22	DC80/HT80
23	DC110/HT110(LCD thermostat)
24	DC90 (LCD touch screen controller)
25	WL-601 (Wireless Thermostat) / WL-602 (Wireless Receiver)
26	EA20...(Electric actuators)
27	EA30 (Electrical actuator)
28	WZA-RF15/18 (Fuel Gas Temperature Control Valve)
29	WZA-RF11/12/16 (Fuel Gas Temperature Control Valve)
30	WZA-CS/CY (Thermostat)
31	WZA-F (High-Power Pressure Type Thermostat)
32	WZA-A/B/C/G (Pressure Type Thermostat)
33	WZA-X/CX/I/H (Pressure Type Temperature Limiter)
34	WZA-SK/SKP/F2000 (Boiler And Water Pump Automatic Controller)
35	WZA-ST (Water Thermometer)
36	WZA-SJ (Intelligent Thermostat)
37	KSD-301/302/304 (Kick Type Thermostate)

KTO 011/KTS 011 (Compact Thermostat)



Characteristic Parameters

- Large setting range ;
- Small size;
- Simple to mount;
- High switching performance.
- KTO 011: thermostat (normally closed); contact breaker for regulating heaters.
- KTS 011: thermostat (normally open); contact maker for regulating of filter fans and heat exchangers or for switching signal devised when temperature limit has been exceeded.

Technical Data

Switch temperature difference	7K (± 4K tolerance)
Sensor element	Thermostatic bimetal
Contact type	Snap-action contact
Contact resistance	<10mΩ
Service life	> 100,000 cycles
Max. Switching capacity	250VAC, 10(2)A 120CAC, 15(2)A DC 30W
EMC	Acc. To EN 55014-1-2, EN61000-3-2, EN61000-3-3
Connection	2-pole terminal, clamping torque 0.5Nm max.: Rigid wire 2.5mm ² Stranded wire (with wire end ferrule) 1 .55mm ²
Mounting	Clip for 35mm DIN rail, En50022 (or for exit filter EF 118 Series)
Casing	plastic according to UL94-HB, black
Dimensions	60 × 33 × 43mm
Weight	Approx. 40g
Fitting position	Variable
Operating/Storage temperature	-45 to +80°C (-49 to +176° F)
Protection type	IP20

KTO 011/KTS 011 (Compact Thermostat)



Overall Dimension

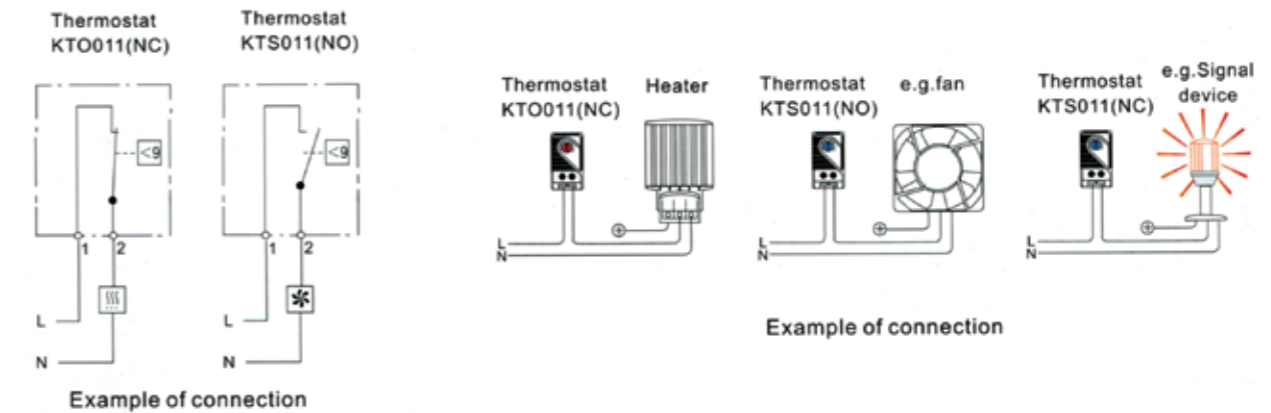
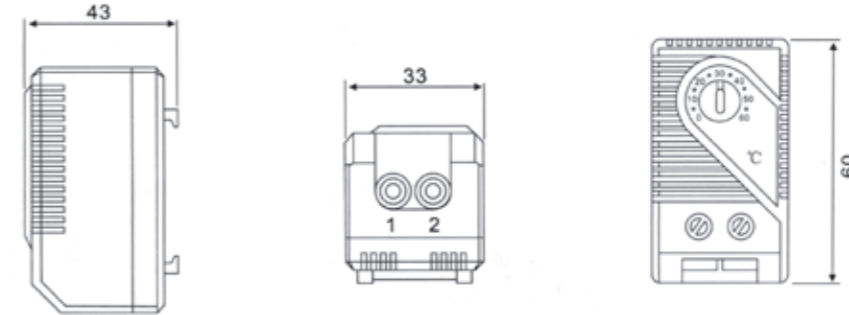

Setting tange	Art.No. Contact breaker (NC)	Art.No. Contact Maker (NO)
0 to + 60°C	01140.0-00	01141.0-00
-10 to + 50°C	01142.0-00	01143.0-00
+20 to + 60°C	01159.0-00	01158.0-00
+30 to+140° F	01140.9-00	01141.9-00
+14 to+122° F	01142.9-00	01143.9-00
0 to + 60°C	01146.9-00	01147.9-00

FTO 011/ FTS 011 (Tamperproof Thermostats)



Characteristic Parameters

- Small size;
- Default temperature setting;
- Easy to install;
- High switching performance.
- Tamperproof (Pre-set) Thermostat FTO 011
Contact breaker/NC (red casing) for regulating heaters or for switching signal devices when temperature has fallen below the minimum value. The contact opens when temperature is rising.
- Tamperproof (Pre-set) Thermostat FTS 011
Contact breaker/NO (blue casing) for regulating filter fans, heaters exchangers, cooling devices or for switching signal devices when temperature limit has been exceeded. The contact closes when temperature is rising.

Technical Data

Sensor element	Thermostatic bimetal
Contact type	Snap-action contact
Contact resistance	<20mΩ
Service life	> 100,000 cycles
Max. Switching capacity	250VAC, 10(2)A 120CAC, 15(2)A DC 30W
Max. Inrush current	AC 10A
EMC	Acc. To EN 55014-1-2, EN61000-3-2, EN61000-3-3
Connection	2-pole terminal, clamping torque 0.8Nm max.:
Mounting	Clip for 35mm DIN rail, En50022
Casing	plastic according to UL94-0, light grey
Dimensions	47 × 33 × 33mm
Weight	Approx.23g
Fiffing position	Variable
Operating/Storage temperature	-20 to +80°C (-4 to +176° F)/-45 to +80°C (-49 to +176° F)
Prot. type	IP20
Approvals	VED+UL File No.E164102

FTO 011/ FTS 011 (Tamperproof Thermostats)



Example of connection

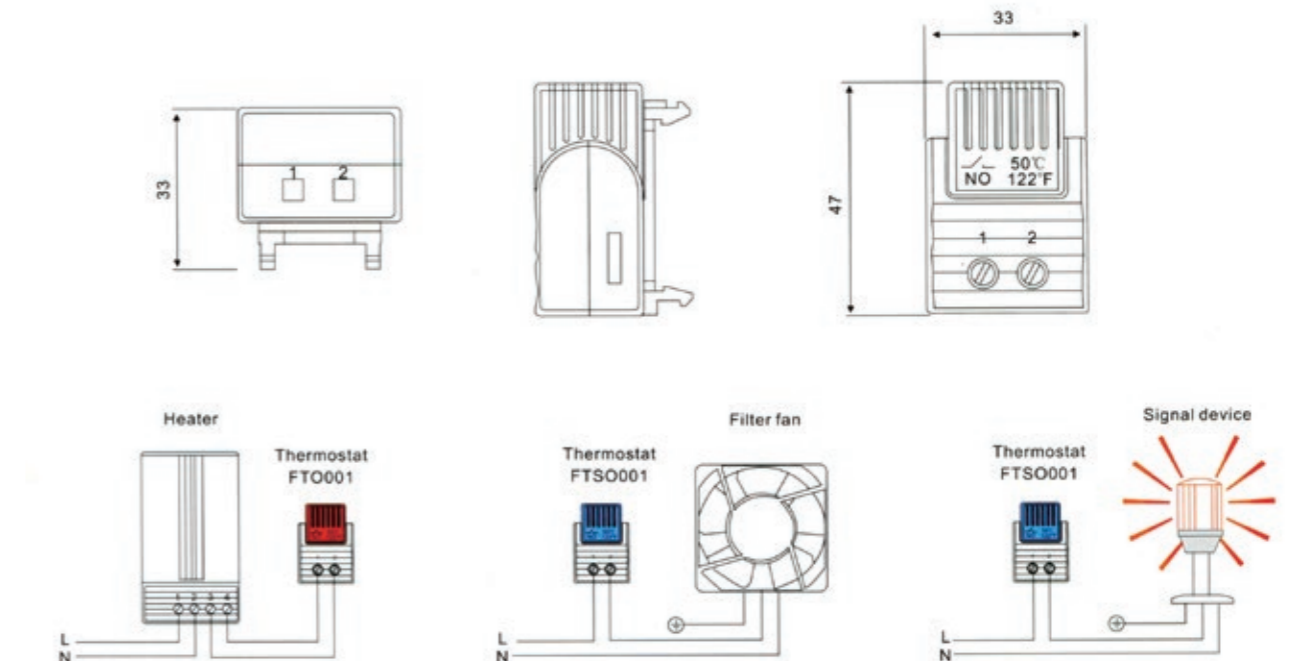

Art.No.	Contact	Switch-off temperature	Switch-on temperature
01160.0-00	Contact breaker(NC)	+15°C +59° F(± 5K tolerance)	+5°C +41° F(± 5K tolerance)
01160.0-01	Contact breaker(NC)	+25°C +77° F(± 5K tolerance)	+15°C +59° F(± 5K tolerance)
		Switch-on temperature	Switch-off temperature
01161.0-00	Contact breaker(NO)	+50°C +122° F(± 6K tolerance)	+40°C +104° F(± 6K tolerance)
01161.0-01	Contact breaker(NO)	+60°C +140° F(± 6K tolerance)	+50°C +122° F(± 6K tolerance)
01161.0-02	Contact breaker(NO)	+35°C +95° F(± 6K tolerance)	+25°C +77° F(± 6K tolerance)

ZR 011 (Dual Thermostat)



Two thermostats in one casing:

Thermostat (contact breaker, normally closed); for regulating heaters.

Thermostat (contact maker, normally open);

for regulating of filter fans and heat exchangers or switching signal devised when temperature limit has been exceeded.

Heaters and cooling equipment can be switched independently from each other with a temperature offset as opposed to the usual change-over contacts.

Technical Data

Switch temperature difference	7K (± 4K tolerance)
Sensor element	Thermostatic bimetal
Contact type	Snap-action contact
Contact resistance	<10mΩ
Service life	> 100,000 cycles
Max. Switching capacity	250VAC, 10(2)A 120CAC, 15(2)A DC 30W
EMC	Acc. To EN 55014-1-2, EN61000-3-2, EN61000-3-3
Connection	4-pole terminal, clamping torque 0.5Nm max.: Rigid wire 2.5mm ² Stranded wire (with wire end ferrule) 1.55mm ²
Mounting	Clip for 35mm DIN rail, En50022
Casing	plastic according to UL94-HB, black
Dimensions	67 × 50 × 46mm
Weight	Approx. 90g
Fitting position	Variable
Operating/Storage temperature	-45 to +80°C (-49 to +176° F)
Protection type	IP20
Approvals	UL file No. E164102

ZR 011 (Dual Thermostat)

Characteristic Parameters

- NO and NC in one casing
- Separate adjustable temperatures
- High switching capacity
- Terminals easily accessible
- Clip fixing

Example of connection

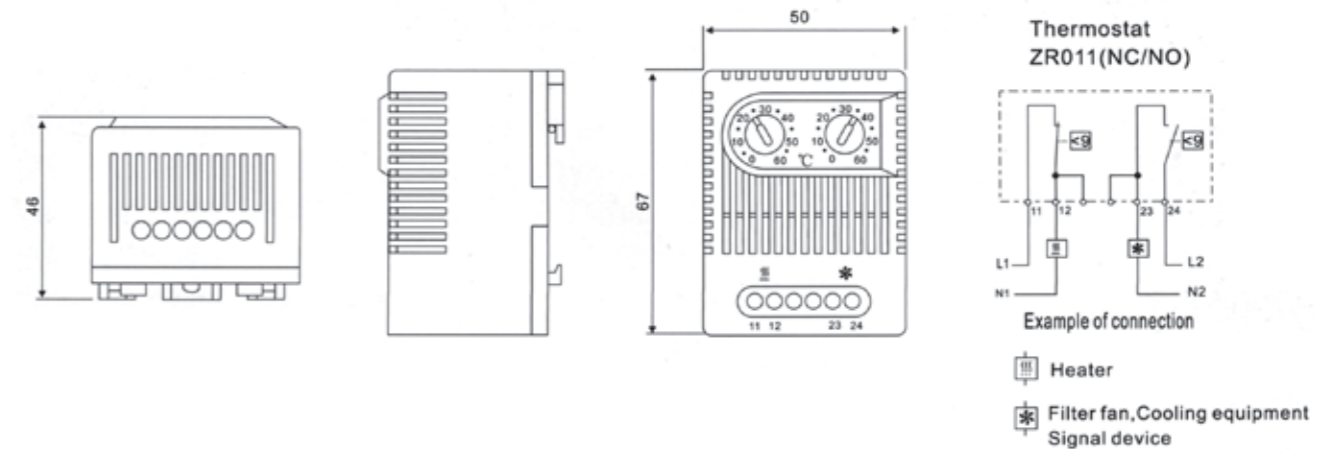

Art.No.	Setting range	Setting range
01172.0-00	Contact breaker, normally closed 0 to +60°C	Contact breaker, normally closed 0 to +60°C
01172.0-01	Contact breaker, normally closed +32 to +140° F	Contact breaker, normally closed +32 to +140° F
01175.0-01	Contact breaker, normally closed 10 to +50°C	Contact breaker, normally closed 20 to +80°C
01175.0-01	Contact breaker, normally closed +14 to +122° F	Contact breaker, normally closed +68 to +176° F
01176.0-00*	Contact maker, normally open 0 to +60°C	Contact maker, normally open 0 to +60°C
01176.0-00*	Contact maker, normally open +32 to +140° F	Contact maker, normally open +32 to +140° F

* For regulating heat exchangers and fans(e.g. LE019) and as an alarm contact for monitoring the interior temperature of electronic enclosures.

MFR 012 (Mechanical Hygrostat)



Introduction

The electromechanical hygrostat MFR 012 is designed to control enclosure heaters so that the dew point is raised when a critical relative humidity of 65 % is exceeded. In this way condensation and corrosion is effectively prevented.

Technical Data

Switch difference*	4% RH (± 3% tolerance)
permissible air velocity	15M/sec
Contact type	Snap-action contact
Contact resistance	<10mΩ
Service life	> 100,000 cycles
Min. Switching capacity	20VAC/DC, 100mA
Max. Switching capacity	250VAC, 5(1)A DC 20W
EMC	Acc. To EN 55014-1-2, EN61000-3-2, EN61000-3-3
Connection	3-pole terminal for 2.5mm ² , clamping torque 0.5Nm max: Rigid wire 2.5mm ² Stranded wire (with wire end ferrule) 1.5mm ²
Mounting	Clip for 35mm DIN rail, En50022
Casing	plastic according to UL94V-0, light grey
Dimensions	67 × 50 × 38mm
Weight	Approx. 60g
Fitting position	Variable
Operating/Storage temperature	0 to +60°C (-32 to +140° -20 to 860°C (-32 to +140° F)
Protection type	IP20

MFR 012 (Mechanical Hygrostat)

Characteristic Parameters

- Adjustable relative humidity
- Change-over contact
- High switching capacity
- Easily accessible terminals
- Clip fixing

Example of connection

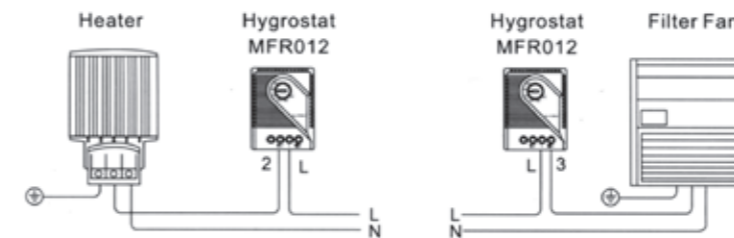

Example of connection

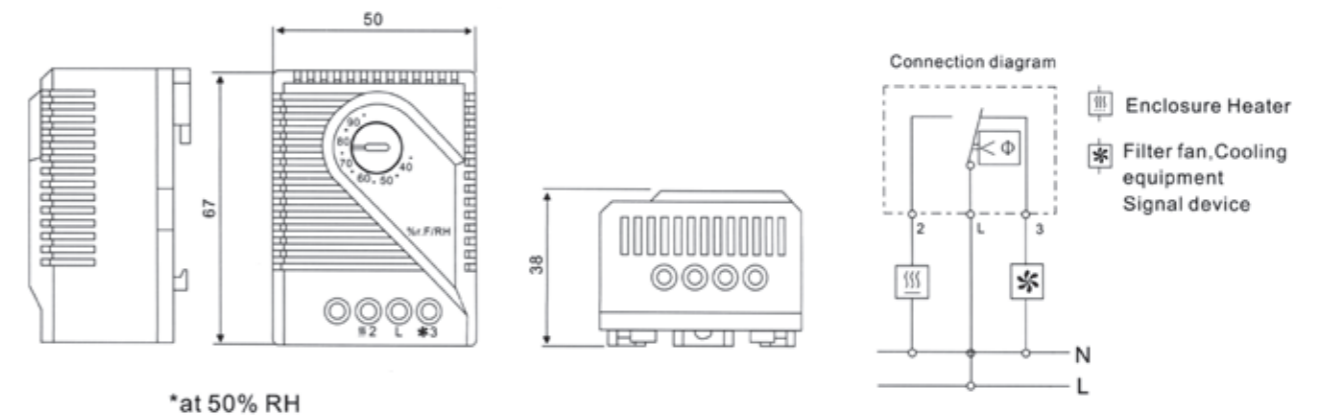

Art No	Setting range
01220.00	30 to 95% RH

MT01 (Mechanical Thermostat)



Introduction

MT01 series of thermostats are usually used on the commercial, industrial and civil constructions, which can control the fan coil of air-conditioning, water valve and wind valveect. It can make the temperature balance in the setting range in the location, and all switches are manual switch. Very simple to manipulate.

Characteristics

- Dialing button for setting the temperature: The place the finger points to is the current temperature value.
- ON/OFF Switch for System: Press ON/OFF Key to turn on/off of the thermostat.
- Working Mode Switch: Press HEATCOOL key to switch the heating/Cooling mode.
- Fan Speed Key: L-M-H, that is, Low speed-Moddle speed-High speed, Wind valve controller does not have this fLJnction.

Functions spec

Model name	Function explanation	Objects controlled
MTOIA	2 tubes fan coil controller, can be set up to control the fan coil	3 gears of fan coil, 2 and 3 wire of motorized valve, magnetic valve on/off wind valve, 3 wires of wind valve.
MTOIB	4 tubes fan coil controller, can be set up to control the fan coil	3 gears of fan coil, 2 and 3 wire of motorized valve, magnetic valve on/off wind valve, 3 wires of wind valve.

Technique Parameters

- Emperature Controlling Range: 10~30°C
- Warking Voltage: 230VAC ± 10%, 50Hz/60Hz
- Current Load: < 3A(Resistant Load)
- Sensing element: Box with the gas.
- Temperature differential: ≤ 1°C (at the 25°C)
- Storing Environment: temperature: -20°C ~55°C , relative humidity: RH < 92%
- Surface material: ABS engineering plastic, manual switch is Off-white, the rest is ivory-white.
- Exiernal dimension: 85 × 130 × 40mm(W × H × D)
- Installation: Standard 86 installing box

MT02 (Fan coil mechanism thermostat)



General

MT02 Mechanical Series thermostat is applied in commercial, industrial and civil building. It can control the fan coil, electric valve and wind valve on the end of cooler central air condition. This keeps the environmental temperature of control place under setting temperature range ,All of the switches are toggle switch which is easy to operate .It will be better if you use this goods with SEV and MDEV Series.

Features

- Mechanical structure design ,It is Stable and durable
- Using toggle plate and toggle switch to set the temperature and patterns which is easy to operate, looks good.
- Using three kinds of wind speed to set low ,mid and high wind.
- Have fan controlled function
- The controller general power will be cut off by power switch without time.
- Easy installation; Stable performance
- Durable use; Easy operation

Main technical data

Model	Rated voltage	Load current	Range of temperature controlling	Temperature difference	Net weight (kg)
MT02A/MT02AF	230V ± 10% AC	≤ 3A (Resistive load)	10°C ~30°C	± 1°C (25°C)	190
MT02D/MT02DF	110V ± 10% AC 24V ± 10% DC	Can be customized load 6A			

Select table

Model	Suitable equipment	Load current	Fan controlled	Temperature difference
MT02A	four-pipe	cold-warm		three gear fan, two line electric valve , electromagnetic valve , Switch air valve , three line air- valve
MT02D	two-pipe	cold		
MT02AF	four-pipe	cold-warm	✓	
MT02DF	two-pipe	cold	✓	

Wiring diagram

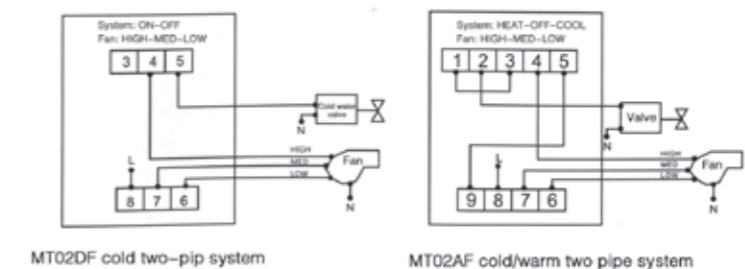

MT02DF cold two-pip system

MT02AF cold/warm two pipe system

MT05 (Heating mechanical thermostat)



Introduction

MT05...SERIES mechanical thermostat is suitable for CLP load control of electrical heating type floor heating system and valve control water cycle radiation floor heating.

Technical Data

- Power supply: AC220V ± 10%
- Working environment: -10°C ~ 60°C Relative humidity: RH < 85%
- Storage environment: -20°C ~ 70°C, Relative humidity: RH < 95%
- Temperature control range: 10°C ~ 30°C (customize 5°C ~ 35°C)
- Load current: ≤ 16A, Negative load
- Temperature control accuracy: ± 1°C
- Protection level: IP40
- Installation: 86 type standard cassette

Function characteristics

- With led light for work state
- Temperature Settings is made by panel wave knob, which is convenient and quick
- With the power switch, which can cut off the power supply controller
- With the power transfer function (AC220V AC24V input, output)

Functions spec

Type	Current	Specification	Control equipment
MT05B(T6360A)	16A	With power light, without the power switch	Heating cable, electric heaters, electrothermal film, electrical heating type heating, water cycle radiation heating system
MT05C(T6360C)	16A	With power light, with the power switch	
MT05E(T6360A)	16A	Without power light, without the power switch	
MT05A(T6360C)	16A	Without power light, with the power switch	
MT05D	6W	AC220V input, AC24V output	

Connection diagram

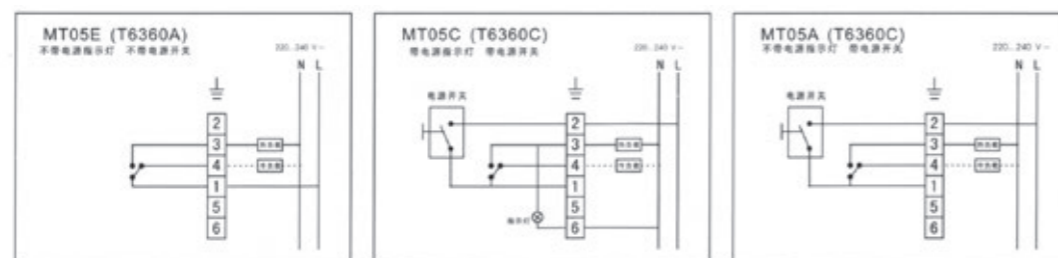

MT06(fan coil mechanical temperature controller)



General

MT06...fan coil mechanical temperature controller apply to commercial, industrial and residential buildings, the end of the central air-conditioning fan coil, electric valve and damper control. Workplace environment controlled by the temperature constant within the temperature range, so the switches are toggle switches, easy to operate. Supporting the use of the recommendations SEV ... series, MDEV ... Series

Functional Characteristics

- Mechanistic Structure design, stable and durable.
- Use dials and toggle switches to set temperature and mode directly, the operation is simple, intuitive, generous
- Three speed mode setting, low, medium, high wind.
- With fan controlled function (refer to the model description)
- With the power switch, do not have to cut the main power supply every time.
- Fashion Concise Compact structure
- Stable performance Easy operation

Main technical data

Model	Rated voltage	Load current	Temperature control range	Temperature departure
MT06A	230V ± 10% AC	≤ 3A (Ohmic load) NA RNA NK NKI load 6A	8°C ~ 30°C	± 1°C (when 25°C)
MT06B	110V ± 10% AC			
MT06E	24 V ± 10% AC			

Select table

Model	Applicable equipment	Mode	Controllable objects
MT06A(T125AAC)	Two control	Single cold	Third gear fan, two-wire electric valve, solenoid valve, switching damper, three-wire damper
MT06B(T125BAC)	Two control	Cold warm	
MT06E(T125FAC)	Four control	Cold warm	

Wiring diagram

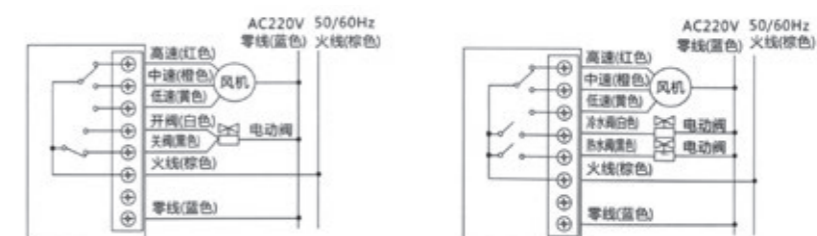

MT07 (Heating mechanical Thermostat)



General

The mechanical Thermostat has aesthetic design and good performance on stability, safety, reliability and sensitivity. It can be free from outside interference and its contactor can be used more than 100 thousand times. The product can control the temperature of the installing environment accurately to decrease the operating cost. What's more, the equipment itself has no consumption of electricity, so it can meet customers' requirement of creating a comfortable living environment. The indoor thermostats from Italy brand MIT are famous in China. Our product also has European CE and Italian IMQ quality certification.

Technical parameters

- Thermostat range: 7°C ~ 30°C
- Thermostat accuracy: 0.4K ~ 0.8K
- Protection class: IP20
- Insulation class: I
- Temperature rate: 1K/15 Min
- Shock capacity: 16 (2.5) A / 250V
- Switch output
- Maximum storage temperature

Feature

- Fashion & concise; Elegant appearance
- Smart&stable; Unique structure

Selection table

Model	Current	Instruction	Related Equipment
MT07B (TA3)	16A	with power indicator, no power switch	heating cable, electric heaters, electric film, Electric heating heater, water circulation radiation heating system
MT07C (TA3)	16A	with power indicator, power switch	
MT07E (TA3)	16A	with no power indicator, no power switch	
MT07A (TA3)	16A	with no power indicator, power switch	
MT07D	6W	input AC 220V, output AC 24V	

Outline size

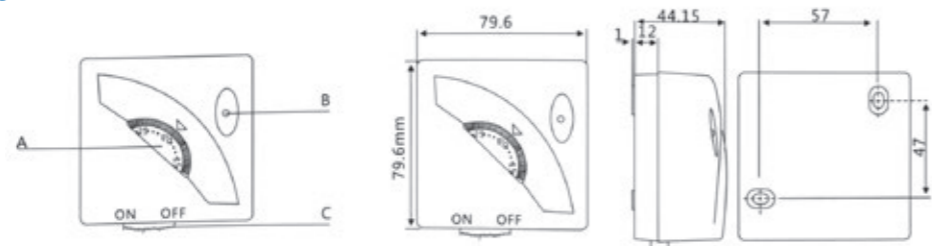

MT08 (Fan coil mechanical thermostat)

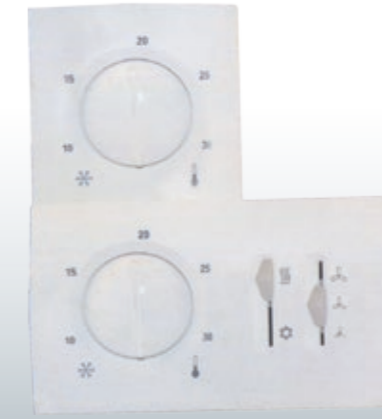

General

MT08 Mechanical Series thermostat is applied in commercial, industrial and civil building. It can control the fan coil, electric valve and wind valve on the end of cooler central air condition. This keeps the environmental temperature of control place under setting temperature range ,All of the switches are toggle switch which is easy to operate .It will be better if you use this goods with SEV and MDEV Series .

Features

- Mechanical structure design ,It is Stable and durable
- Using toggle plate and toggle switch to set the temperature and patterns which is easy to operate, looks good .
- Using three kinds of wind speed to set low ,mid and high wind .
- Have fan controlled function
- The controller general power will be cut off by power switch without time .
- New appearance; Unique structure
- High technic; Elegant and durable

Main technical data

Model	Rated voltage	Load current	Range of temperature controlling	Temperature difference
MT08A	230V ± 10% AC	≤ 3A (Resistive load) Can be customized load 6A	8°C ~30°C	± 1°C (25°C)
MT08B	110V ± 10% AC			
MT08E	24V ± 10% DC			

Select table

Model	Suitable equipment	Load current	Temperature difference
MT08A (T125AAC)	two-pipe	cold	three gear fan, two line electric valve , electromagnetic valve , Switch air valve , three line air- valve
MT08B (T125BAC)	two-pipe	cold-warm	
MT08E (T125FAC)	four-pipe	cold-warm	

Outline size

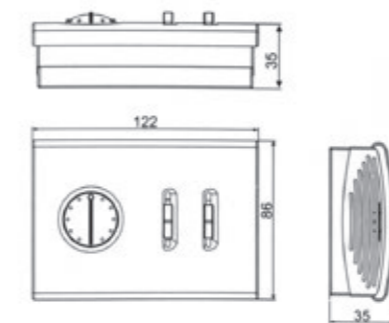

Installation pate size

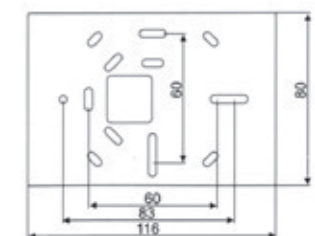

ET03 (Electronic Thermostat)



Introduction

The RTC70.XX is used for 2-position control with on/off output for the control the temperature by means of an NTC sensor placed externally or internally in the thermostat. The thermostat acquires the room temperature with its built-in sensor or floor sensor, and the heating contact will close when the room temperature falls below the selected set point.

Application

For the control of warm-water (floor) heating systems and direct electric heating systems used in Commercial buildings, Residential buildings, Light industrial buildings ...

Features

- LED indicator is light when heating is on
- With manual switch and knob for easy operation
- On/off control output for heating device

Technical Data

- Voltage: AC230V
- Current: 16A(maximum)
- Power consumption: 3680W
- Setting range: 4°C ~45°C
- Switching differential: $\pm 0.5K$
- Ambient temperature: -5°C ~50°C
- Protective housing: IP20
- Housing material: self-extinguishing PC
- Floor sensor: rubber-thermoplastic NTC sensor
- Cable length is 3m

ET05 (Mechanical Thermostat)



Characteristics

- Application: control of central air conditioner or heating appliance for room temperature
- Temperature control range: 10°C ~30°C
- Work voltage: 220V/24V-60Hz
- Max load: 10A-16A
- SENSOR type: gas filled syphon
- With on/off Switch, without LED indicator for power

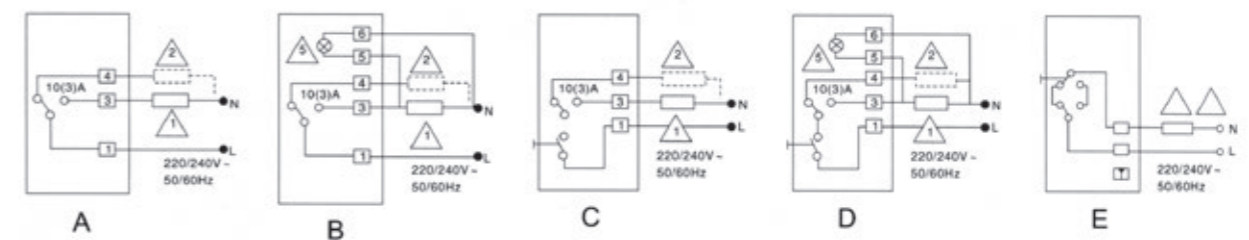

Room Temperature Controller

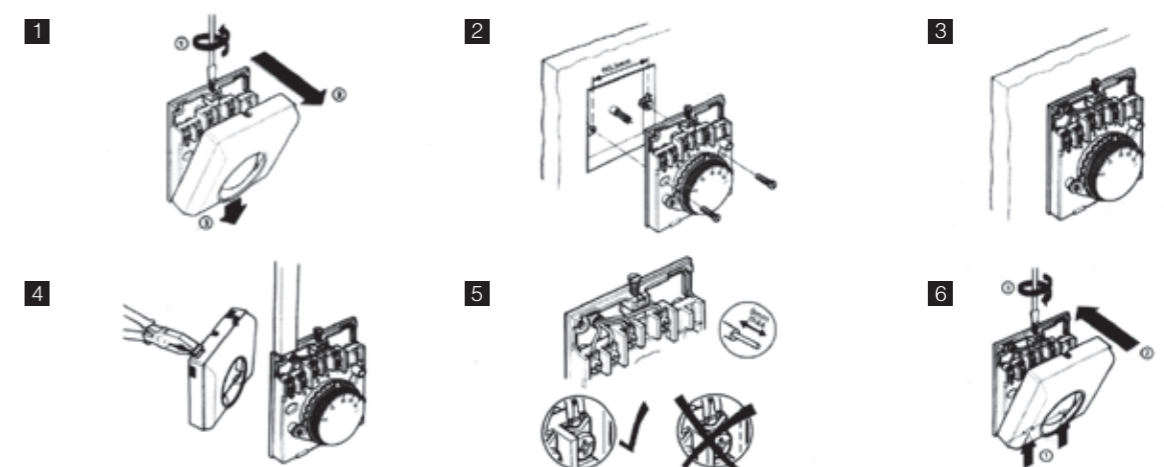

FS60/FS30 (Fan three gear speed switch)



General

FS... Series three gear speed switch is suitable for office, hotel, high-grade office building. It can control the three gear motor of the end coil of central air-conditioning. It has modern appearance and stable performance, and can afford relative high power load.

Technical data and feature

- Rated voltage: 230V AC +/- 10% 50/60Hz
- Load current: 3A resistive load
- Cover material: Environment-friendly fire retardant ABS
- Ambient temperature: -25 °C ~55°C three gears
- Independent switches: Longer life than the traditional rotary switch, more convenient, smarter
- LCD display: LCD screen display, high grade
- Control scape: control three gear fan, two line valve, three line valve
- Simple and concise; Durable in use
- Easy operation; Economical and practical

Selection table

Model	Load current	Control equipment
FS20	3A	Fan three gear air speed
FS30	3A	Fan three gear air speed, LCD display gear
FS60	8A	Fan three gear air speed, two line electric valve, three line electric valve

Wiring diagram

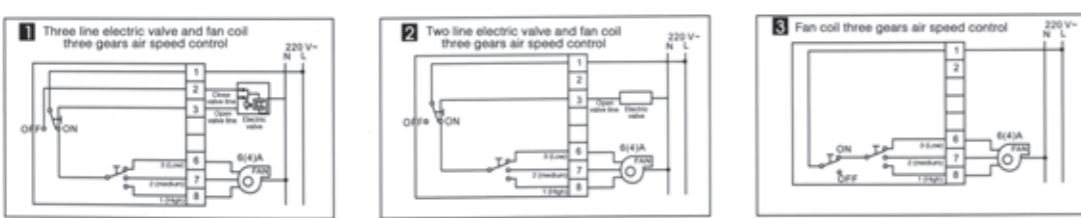

SMT (Smart Constant Thermostats)



Introduction

SMT Series smart constant thermostats can be used in business, industry, civil building for control of blower fan scroll and water valve of central air-condition heating and air conditioning system.

Key function: Set HOT/COOL mode; Set speed of equipments, such as, AUTO--FAST--MIDDLE--LOW; Timing: 0-48 hours; Correct indoor temperature; Power switch.

To control the speed of 3-gear fan scroll, 3-line electric valve and 2-line electric valve, electromagnetic valve, switch air valve or 3-line air-valve.

Electric Parameters

- Rated voltage: 220V/AC, 50/60 Hz
- Rated current: <5A
- Constant temperature scope: 5°C ~35°C
- Temperature differential: ± 1 °C

Overall Dimension

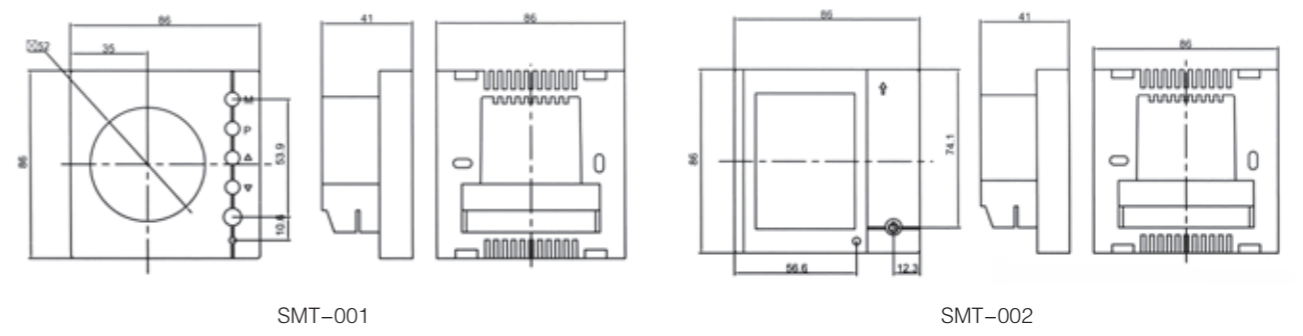

DC40/HT40 (LCD thermostat)



General

HT40... Series thermostat is used for temperature control of single room of residential building and commercial building, and used for the electric load control in electric heating type floor heating system or the water valve control in water cycle radiation type floor heating system.

DC40...Series thermostat is applied in commercial, industrial and civil building. It can control the fan coil, electric valve and wind valve on the end of cooler central air condition. It is advised to used with electric valve like SEV...Series, electric heating executive series, MDEV... Series

Feature

- Universal LCD display (symbol + English + Chinese).
- Indoor temperature correction and compensation function (can be done directly by button on panel).
- Multi-button household appliance operation interface, supper thin,supper miniature design.
- 5V power supply switch, 8 hours timing switch on/off.
- Power off memory, remembering the working state when power off, when power on, automatically recover previous working state.
- Fan' speed can be controlled manually or automatically.
- Low temperature protection function (As low temperature, start automatically).
- LCD digital display; Intelligent Control.
- Economical & Practical; Easy Operation.

Selection table

Model	Load current	Model description	Controlling device
DC40A	3A	control electric valve, without controlling fan coil	Three gear fan, two line electric valve, electromagnetic valve, switching type valve, three line fan valve
DC40AF		control electric valve,and control fan coil	
HT40W	16A	double temperature double control, single temperature control	suitable for controlling the water valve in water cycle radiation floor heating system
HT40E		double temperature double control, single temperature control	

DC50/HT50 (LCD thermostat)



General

HT50... Series thermostat is used for temperature control of single room of residential building and commercial building, and used for the electric load control in electric heating type floor heating system or the water valve control in water cycle radiation type floor heating system.

DC50...Series thermostat is applied in commercial, industrial and civil building. It can control the fan coil, electric valve and wind valve on the end of cooler central air condition. It is advised to used with electric valve like SEV...Series, electric heating executive series, MDEV... Series

Feature

- Weekly cycle, daily set 6 time interval and corresponding setting temperature.
- The operation mode of manual control and temporary control is optional
- Suitable for the control of electric heating equipment and the control of electric power valve of water system heating
- Fan controlled anti-condensation, after closing valve, keep operation under any state for 30 seconds on soft wind.
- With infrared remote control function, remote controller is optional
- Indoor temperature measurement, earth temperature over-heating protection, low temperature protection
- Easy Operation; Elegant Appearance
- Time programming; LCD Display

Technical Data

- Rated Voltage: AC24V, 110V, 230V (220V)
- Load Current: 3A(16A)
- Power: 4W
- Temperature control range: 5~90°C
- Protection grade: IP20
- Cover material: fire retardant PC

Selection table

Model	Load current	Model description	Controlling device
DC50A	3A	control electric valve, without controlling fan coil	Three gear fan, two line electric valve, electromagnetic valve, switching type valve, three line fan valve
DC50AF		control electric valve,and control fan coil	
HT50W	16A	double temperature double control, single temperature control	suitable for controlling the water valve in water cycle radiation floor heating system
HT50E		double temperature double control, single temperature control	

DC80/HT80 (LCD thermostat)



General

HT80... Series thermostat is used for temperature control of single room of residential building and commercial building, and used for the electric load control in electric heating type floor heating system or the water valve control in water cycle radiation type floor heating system.

DC80...Series thermostat is applied in commercial, industrial and civil building. It can control the fan coil, electric valve and wind valve on the end of cooler central air condition. It is advised to used with electric valve like SEV...Series, electric heating executive series, MDEV... Series

Selection table

Model	Load current	Model description	Controlling device
DC50A	3A	control electric valve, without controlling fan coil	Three gear fan, two line electric valve, electromagnetic valve, switching type valve, three line fan valve
DC50AF		control electric valve, and control fan coil	
HT50W	16A	double temperature double control, single temperature control	suitable for controlling the water valve in water cycle radiation floor heating system
HT50E		double temperature double control, single temperature control	suitable for controlling the electric load valve in electric heating floor heating system

DC110/HT110(LCD thermostat)



General

DC110...series thermostat is applied in commercial, industrial and civil building. It can control the fan coil, electric valve and wind valve on the end of cooler central air condition. It is advised to used with electric valve like SEV...series, electric heating executive series, MDEV... Series.

HT110... Series thermostat is used for temperature control of single room of residential building and commercial building, and used for the electric load control in electric heating type floor heating system or the water valve control in water cycle radiation type floor heating system.

Feature

- Super large LCD screen;
- Four speed mode setting, low, medium, high and auto wind adjustment;
- Can be connected to three line electric valve(two way or three way)and compatible with three line electric valve, electromagnetic valve or air valve;
- Indoor temperature display range: 1.0°C ~ 5 °C , temperature display resolution rate 0.2 °C , temperature error is less than + 1°C ;
- With sleeping function, cosy room temperature, economical and energy saving;
- Power off memory, remembering the working state when power off, when power on, automatically recover previous working state;
- Room temperature adjustment: directly use button to adjust room temperature measured value;
- Fan controlled anti-condensation, after closing valve, keep operation under any state for 30 seconds on soft wind. Or without controlled function;
- Remote control function, remote controller is optional;
- Electric auxiliary heating function;
- Large LCD digital display; Intelligent control; Precise temperature control; Elegant appearance.

Technical Data

- Rated voltage:220VAC+/-10%, 50/60Hz
- Load current: <3A (resistive load)
- Temperature control range:5.0 °C ~ 35.0 °C
- Material and color: White PC/ABS fire retardant material
- Power consumption (self): < 1.5W
- Temperature control accuracy: +/- 0.5 °C
- Outline size: 86*86*13mm (Panel: length x width x thickness)

Selection table

Model	Load current	Model description	Controlling device
DC110A	3A	control electric valve, without controlling fan coil	Three gear fan, two line electric valve, electromagnetic valve, switching type valve, three line fan valve
DC110AF		control electric valve, and control fan coil	
HT110W	16A	double temperature double control, single temperature control	suitable for controlling the water valve in water cycle radiation floor heating system
HT110E		double temperature double control, single temperature control	suitable for controlling the electric load valve in electric heating floor heating system

DC90 (LCD touch screen controller)



General

The thermostat adopts advanced touch control technology, large LCD screen display, blue back light, fashionable metal panel technology, ABS flame retardant materials, special metal base; Elegant appearance design, mature stable procedures, accurate time, ten points once accurate display.

Feature

- Luxurious appearance texture
- Sensitive touch soft key
- Accurate temperature control
- Simple and easy installation
- Reliable product quality
- Panel color can free choice
- LCD touch; Luxury
- Supper large screen; Intelligent control

Standard configuration

- Touch soft key
- Memory power
- The clock display
- Blue back light
- Refrigeration function
- Heating function
- Ventilation function
- Sleep function
- Timing open and shut down
- Automatic wind speed, manual wind speed

Technical data

Working voltage	220VAC ± 10%	Working frequency	50/60HZ
Current load	3A	Consumable power	1w
Display module	LCD	Temperature detection	ntc
Display temperature	0-45°C	Controlled temperature	0-45°C
Mounting hole distance	60mm	Clock error	< 3S/day

Overall dimension

Type	L(mm)	W(mm)	H(mm)
DC90-01	106	90	13
DC90-02	100	90	14
DC90-03	86	90	14
DC90-04	86	100	14

WL-601 (Wireless Thermostat) WL-602 (Wireless Receiver)



General

WL-601 Wireless Thermostat is available in WL-602 wireless receiver. It applies advanced wireless technology to achieve transmitting and receiving data by wireless methods. This thermostat with the function of adjusting the indoor temperature, can be programmed to control temperature in different time periods and achieve programming freely 4 periods per day, 7days a week. This series can setting indoor temperature in different time periods based on the user's working schedules and patterns of life. It is mainly applied to water heating system and has good scalability. WL-601 thermostat transmit signal to wireless receiver and executive command and then feedback the result to the wireless thermostat after comparing the difference between the indoor temperature and the setting temperature. Then the present data would be transmitted to the control center immediately through net. It would be user-friendly by network controlling and setting the temperature in different time periods.

Technical data

WL-601 :

- Power supply: 2pcs N0.5 AA Alkaline cell
- Working conditions: -9°C ~80°C
- Storage conditions: -20°C ~70°C
- Temperature range: 5°C ~35°C
- Temperature accuracy: ± 1°C
- Open distance: >100m
- Rated output power: <200W
- Shell material: PC+ABS
- Protection Grade: IP40

WL-602 :

- Power supply: 220V
- Connection mode: terminal crimping
- Eight combinations
- Signal transmission mode: RFID

Feature

- Wireless remote control, no wiring when installation, time and cost saving
- Low battery display
- Time switch
- Thermoregulation and calibration
- Setting the clock and week
- High speed, medium speed and low speed controlling
- Setting time freely 4 periods per day, 7days a week
- With large LCD screen and attractive appearance
- Beautiful and durable; Safe and reliable
- Energy-saving and environmental friendly; smart LCD display

Outline size

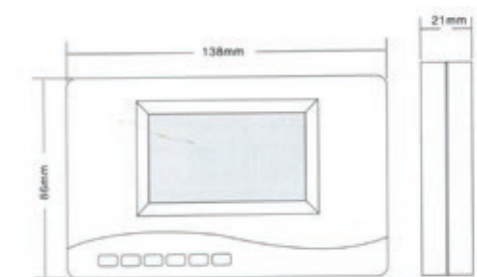

EA20...(Electric actuators)



General

EA20...type Electric actuators is the two-point switch structure implementation , applied to the implementation of the radiators, floor heating system or zone valves, under the room thermostat and an electric switch control can be automatically closed system flow rate, the drive only used as the switch actuators.

Working principle

- When electric actuators power on,the induction body heated inflated, valve open.
- When power cut, valve recover to closed status.
- Room thermostat by controlling the electric drive power on or off to control valve.

Valve adapter

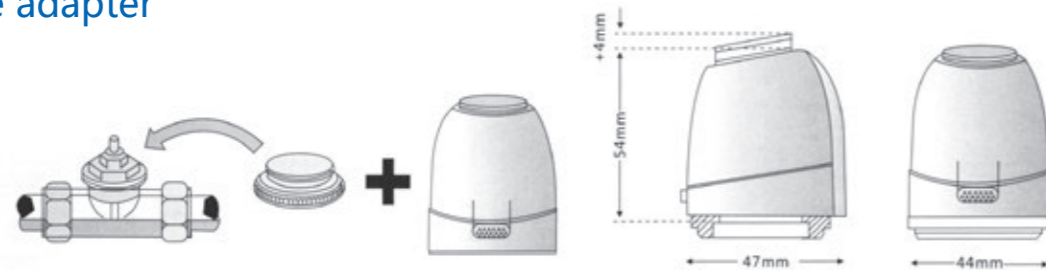

Different valve adapters match various valve and the thermostatic valve core of water segregator

Specification size and technological

Type	EA20.23	EA20.24
Output voltage	AC230V ± 10%	AC24V ± 10%
Initial Current	about 30mA	about 2A
Power Consumption	4W(after stabled)	6W(after stabled)
Protection Grade	IP54	
Working stroke	≥4.0mm	
Working temperature	0°C ~50°C	
Storage temperature	-200°C ~700°C	
Safe class	II(double insulation)	
Cable length	100cm(customizable)	
Working time	≤5 minutes(25°C)	
CE certificate	En60730	
Size	62mm × 39mm × 39mm	

EA30 (Electrical actuator)



General

EA30 series electric actuator is a two-point switch actuating mechanism , applied to the radiators, floor heating systems , or regional implementation of the valve. Under the control of the room thermostat and other motor switches can automatically shut down the system flow. This actuator can only be used as switching actuators.

Feature

- When the electrical actuator powers on, the inductor is heated to expand and then the valve opens.
- When power is off , the valve would restore to the off state
- Room thermostat control by the electric actuator power on and off to control the valve
- The degree of opening indicate the position of travel distance.
- Easy and fast nut separate installation and easy dismantling
- Powerful function, Easy operation; Smart and stable, Well-made

Valve adapter

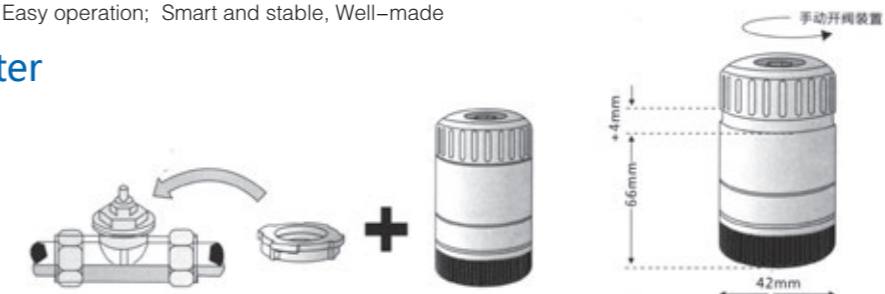

Different valve adapters match various valve and the thermostatic valve core of water segregator

Specification size and technological

Type	EA10.23/EA20.23	EA10.24/EA20.24
Output voltage	AC230V ± 10%	AC24V ± 10%
Initial Current	about 300mA	about 2A
Power Consumption	4W(after stabled)	6W(after stabled)
Protection Grade	IP54	
Working stroke	≥4.0mm	
Working temperature	0°C ~50°C	
Storage temperature	-200°C ~700°C	
Safe class	II(double insulation)	
Cable length	100cm(customizable)	
Working time	≤5minutes(25°C)	
CE certificate	En60730	
Size	62mm × 39mm × 39mm	

WZA-RF15/18(Fuel Gas Temperature Control Valve)

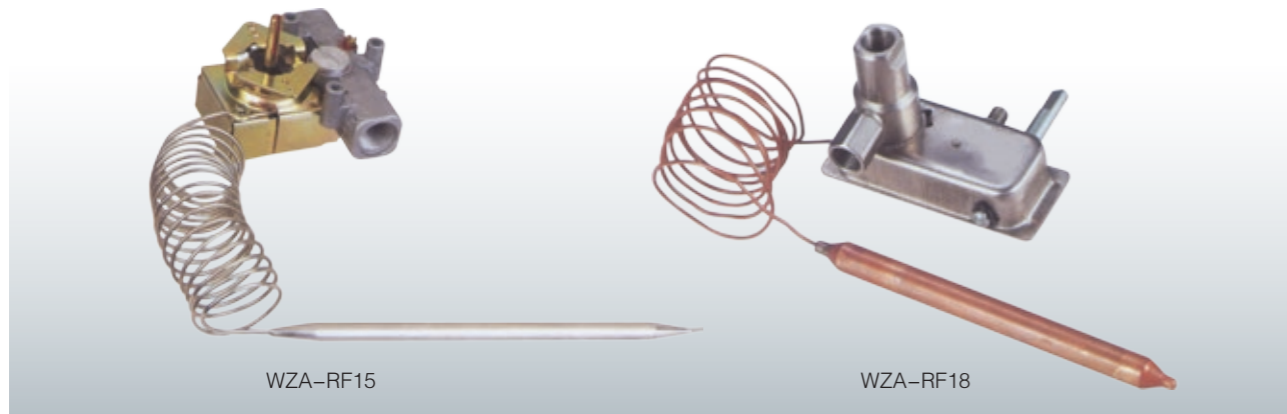

Introduction

WZA-15/18 series gas temperature control valve products are the latest gas pipe temperature controller developed by our company, has applied for state patent of utility model and design patent, and certified to CSA.

The products have features of small volume, compact structure and power free. It can directly control the gas pipe by using switch. Burst switch resets automatically, with good constant temperature effect. It may be applied in gas warmer, turkey cooker, storage type water heater, wall-mounted warming oven, gas temperature control valve with open fire and self extinguish protection for gas air condition.

Characteristic Parameters

- Applicability: turkey cooker, oven, gas air condition, fireplace, etc.
- Gas pressure: 1/2PSI (5PSI、 10PSI)
- Range of temperature control: 0°C ~ 120°C (90°C ~220°C)
- On/off difference: 2°C ~9°C
- Structure model: burst structure, reset automatically, and shift purposively, strong thermal power, without producing charcoal deposit to cooker body or gas appliances.

Overall Dimension

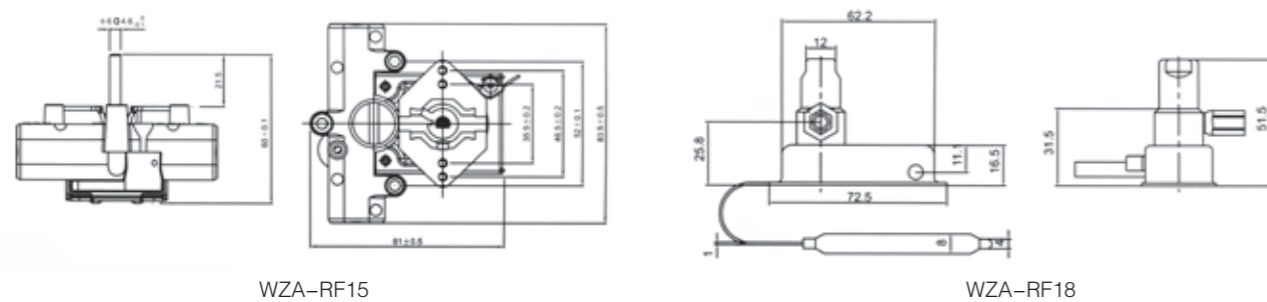

WZA-RF11/12/16 (Fuel Gas Temperature Control Valve)



Introduction

WZA-RF 11/12/16 series temperature control valve, Applicable for fuel gas oven, fuel gas boiler and western style kitchen, Constant open flame fuel gas temperature control valve.

Parameters

Temperature control range	Open point deviation	Break point deviation	On/off difference
160°C ~220°C	±3	±3	±5

Overall Dimension

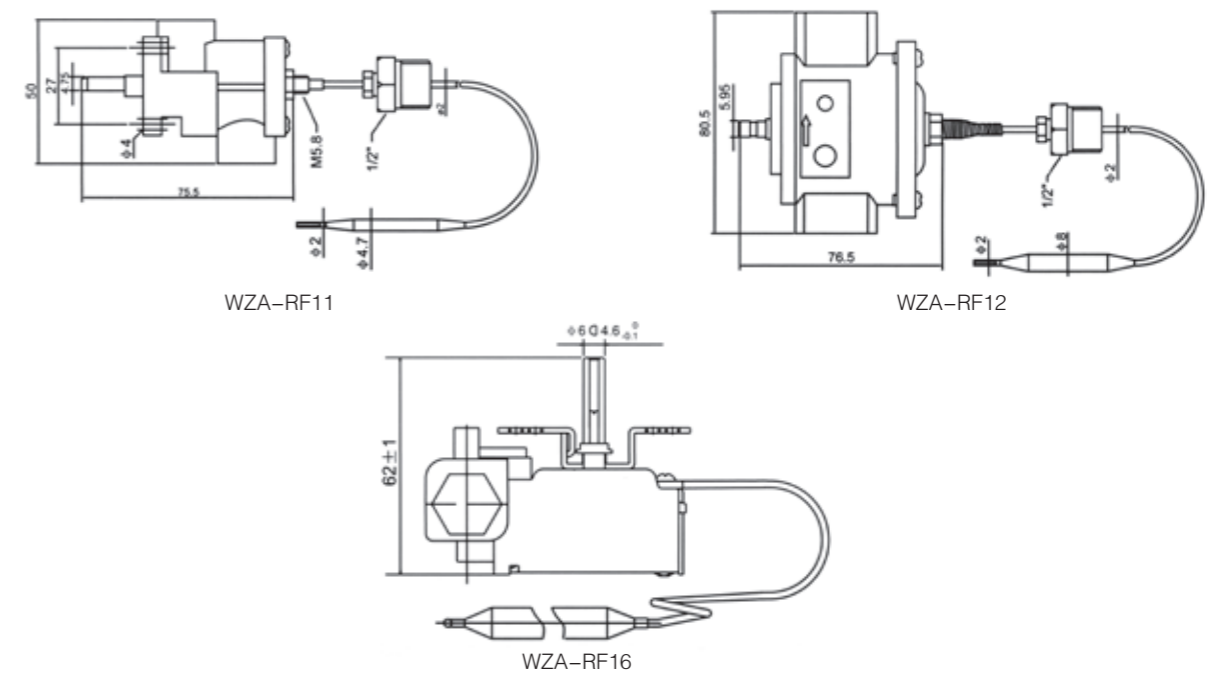

WZA-CS/CY (Thermostat)



Introduction

WZA-CS/CY Series thermostat of pressure type is applicable for hot water pipeline, boiler, Bimetal and pressure type temperature controllers.

Parameters

Temperature control scope (°C)	Start/stop differential(°C)	Temperature control precision(°C)	Rated voltage and current
10~60	>2<9	± 4	220V 16A
30~90	>2<9	± 5	220V 16A
30~110	>2<9	± 6	220V 16A

Overall Dimension

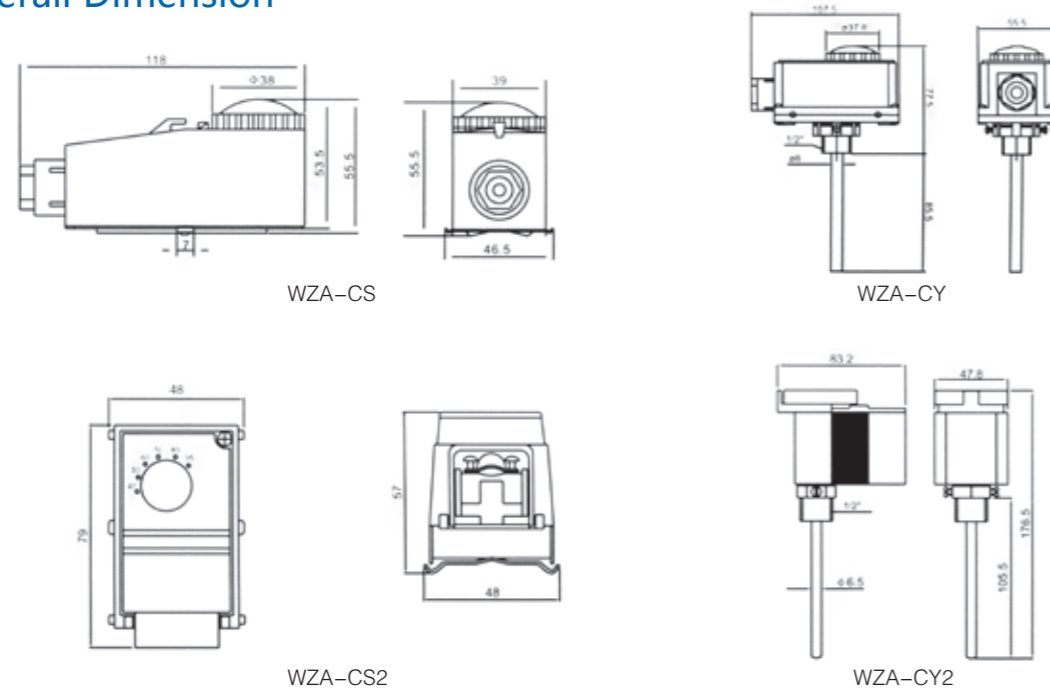

WZA-F (High-Power Pressure Type Thermostat)

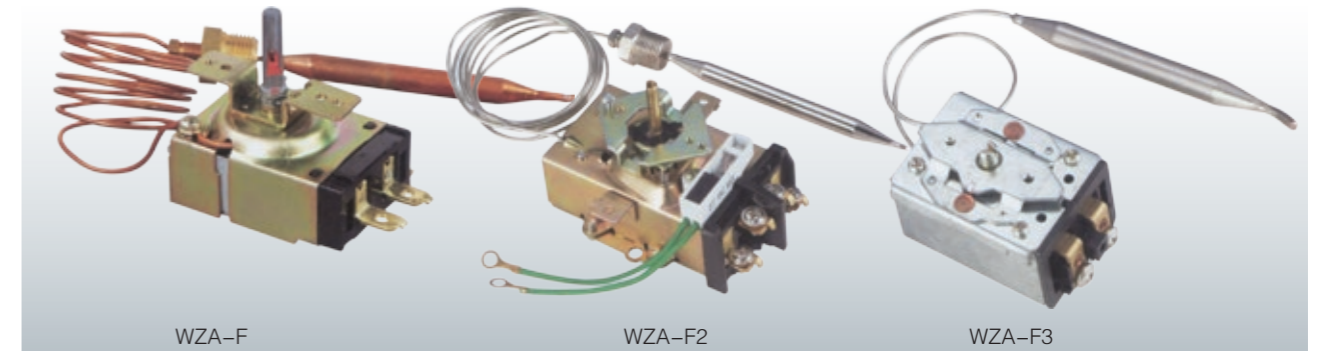

Introduction

WZA-F Series high-power thermostat of pressure type is applicable for electric oven, boiled water device, and kitchenware.

Parameters

Temperature control scope(°C)	Start/stop differential(°C)	Temperature control precision(°C)	Rated voltage and current
30~85	>2<9	± 5	220V 30A
30~110	>2<9	± 6	
50~200	>2<9	± 6	
50~320	>2<9	± 9	

Overall Dimension

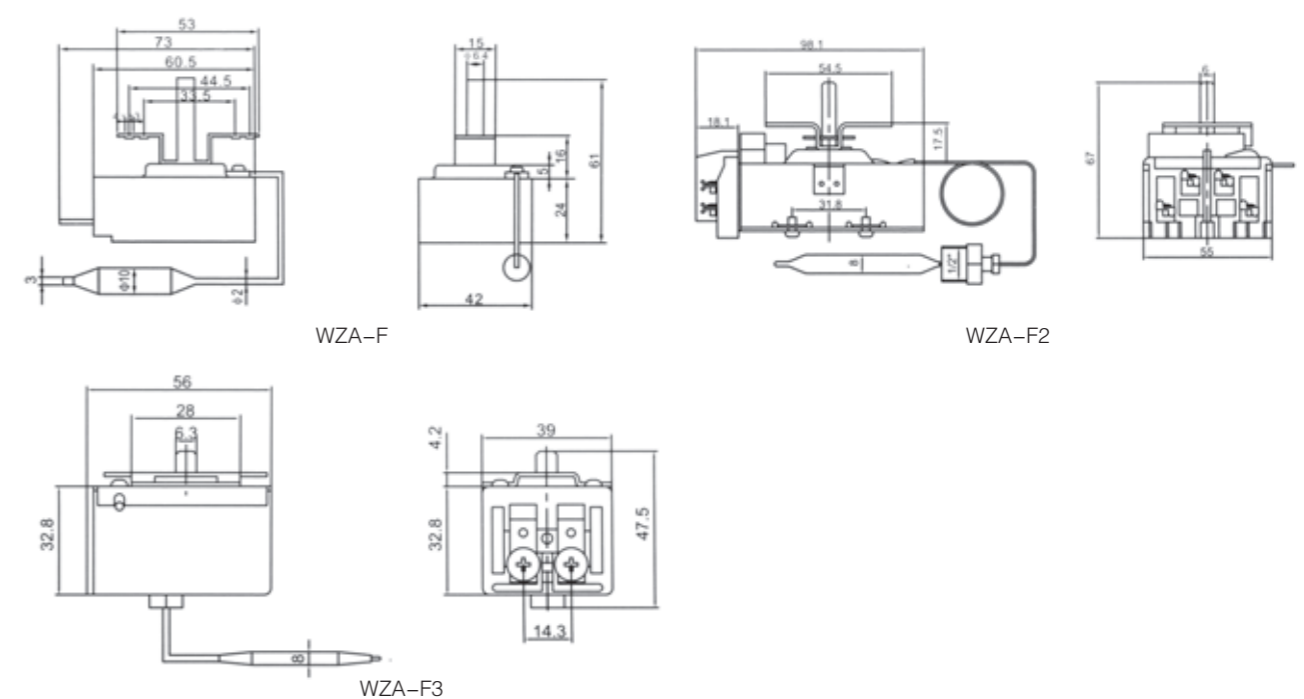

WZA-A/B/C/G (Pressure Type Thermostat)

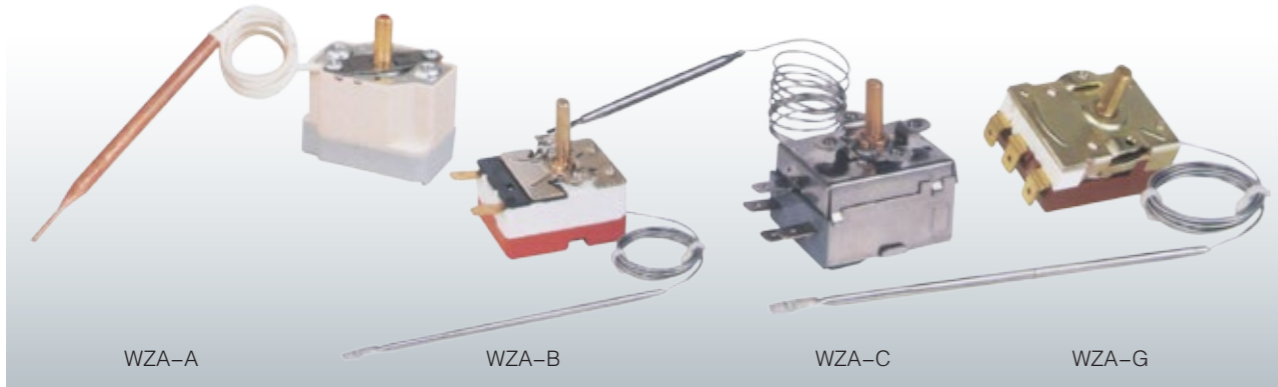

Introduction

WZA-A/B/C/G Series thermostat of pressure type is applicable for electric water heater, kitchenware, washing machine, electric oven and boiled water device.

Parameters

Temperature control scope(°C)	Start/stop differential(°C)	Temperature control precision(°C)	Rated voltage and current
10~60	>2<9	± 4	220V 16A
30~85	>2<9	± 5	
30~110	>2<9	± 6	
30~230	>2<9	± 8	
50~320	>5<10	± 9	

Overall Dimension

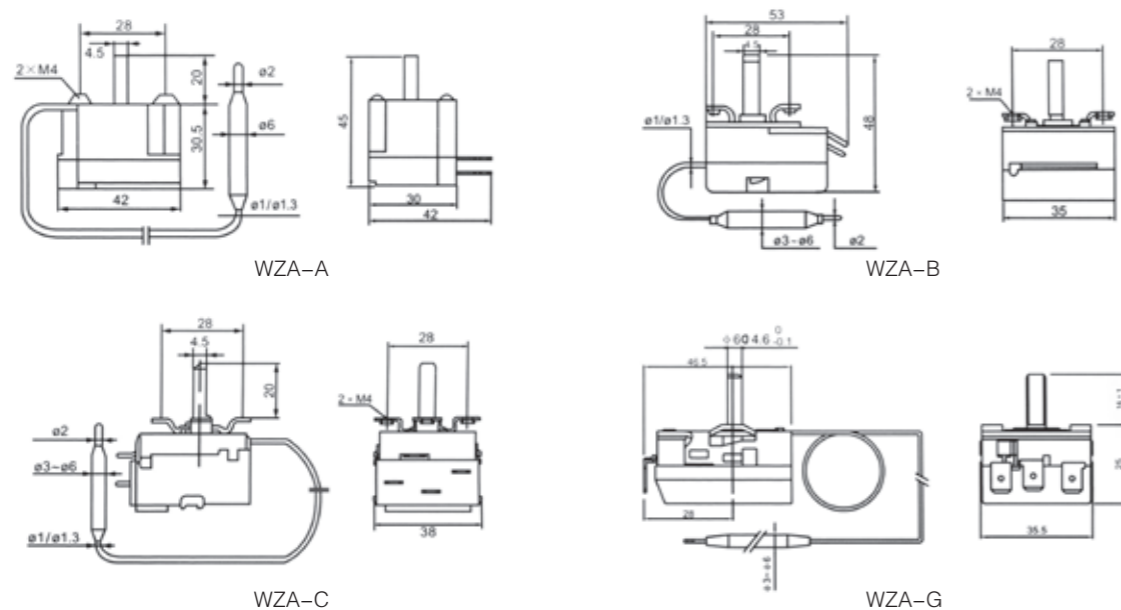

WZA-X/CX/I/H (Pressure Type Temperature Limiter)

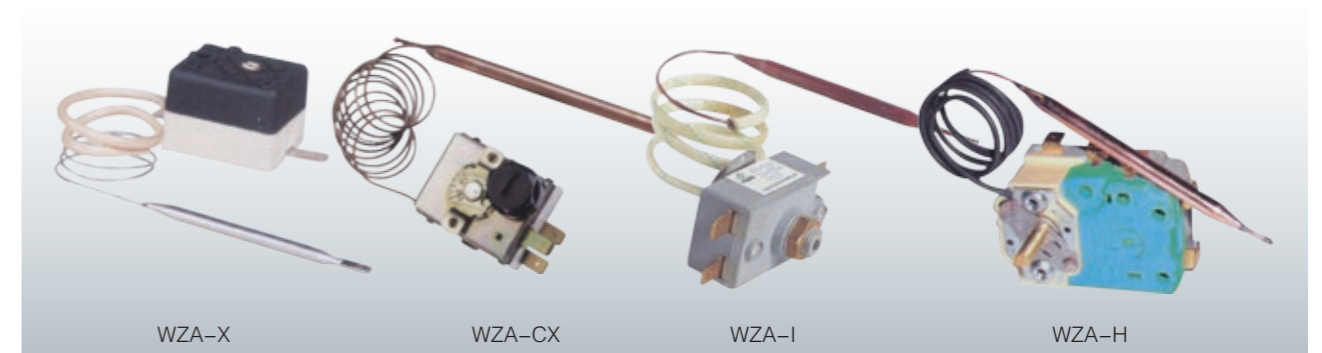

Introduction

WZA-X/CX/I/H Series temperature limiter of pressure type is applicable for electric water heater and electric oven kitchenware, Pressure type temperature limiter with manual reset and leakage protection.

Parameters

Temperature control scope(°C)	Temperature limiting precision(°C)	Rated voltage and current	Notes
50	± 3	220V 16A	Manual reset
90	± 3	220V 16A	
120	± 3	220V 16A	
210	± 5	220V 16A	
320	± 8	220V 16A	

Overall Dimension

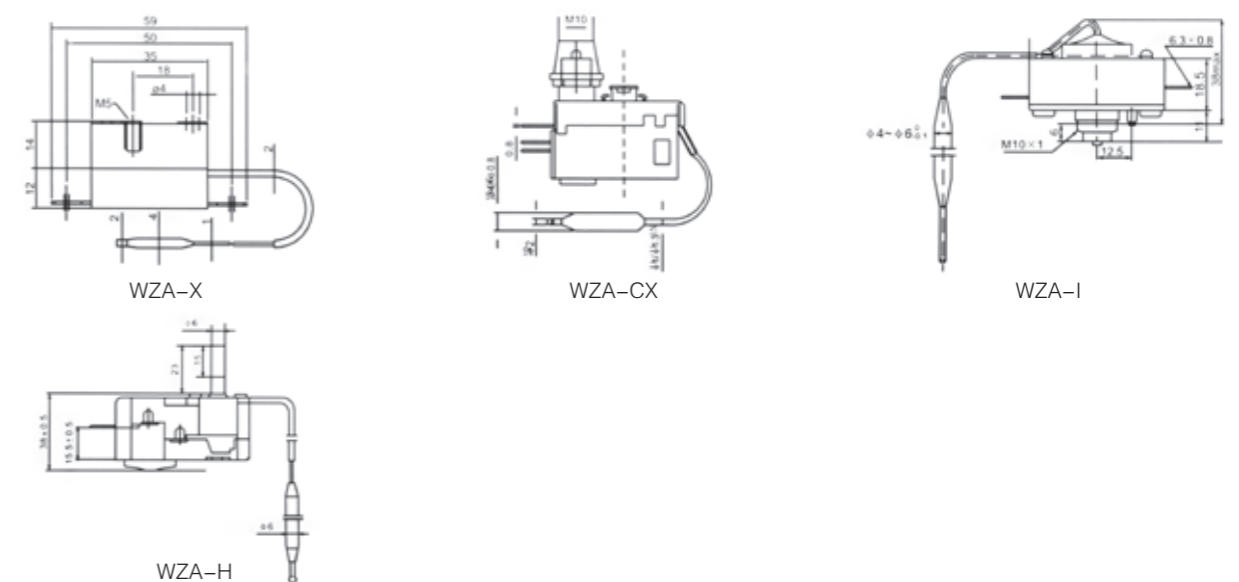

WZA-SK/SKP/F2000 (Boiler And Water Pump Automatic Controller)



WZA-SK

WZA-SK-II

WZA-SKP-05

WZA-SKP-05-1

WZA-SKP

WZA-SKP-II

WZA-SKP-V

F2000

Introduction

WZA-SK/SKP/F2000 Series boiler and water pump automatic controller is one of our company newest development new style electronic formula automatic thermostats.

Parameters

Type	Rated Voltage	Rated Current	Load power	Temperature Ranges	Precision	Standby power	Appearance size(mm)
WZA-SK	AC220	5A	≤ 750W	30-99°C	± 3°C	3W	96 × 126 × 48
WZA-SK-II	AC220	5A	≤ 750W	30-99°C	± 3°C	3W	86 × 136 × 50
WZA-SKP-05	AC220	5A	≤ 750W	0-99°C	± 1°C	3W	86 × 136 × 38
WZA-SKP-05-1	AC220	5A	≤ 750W	10-99°C	± 1°C	3W	86 × 136 × 38
WZA-SKP	AC220	15A	≤ 2.5KW	0-99°C	± 1°C	5W	110 × 160 × 52
WZA-SKP-III	AC380	12A	≤ 7.5KW	0-99°C	± 1°C	5W	145 × 216 × 70
WZA-SKP-V	AC380	20A	≤ 12KW	0-99°C	± 1°C	5W	300 × 420 × 120
F-2000	AC220	15A	≤ 2.5KW	0-99°C	± 3°C	3W	58 × 86 × 35

WZA-ST (Water Thermometer)



WZA-ST/1

WZA-ST/2

WZA-ST/3

WZA-ST/5

WZA-ST/6

WZA-ST/7

Introduction

WZA-ST Water thermometer, applicable for indicating the temp. of stainless steel boiled water device and other heaters.

Parameters

Type	Temperature control scope(°C)	Temperature Precision	Notes
WZA-ST/1	20-100	± 3°C	Max.temperature: 120~350°C Temperature sensing part: 120°C ~350°C Body: 60°C /120°C
WZA-ST/2	± 40/0-120	± 3°C	
WZA-ST/3	± 40/0-120	± 3°C	
WZA-ST/5	0-350	± 5°C	
WZA-ST/6	0-120	± 3°C	
WZA-ST/7	20-120	± 3°C	

WZA-SJ (Intelligent Thermostat)



Introduction

WZA-SJ thermostat with rated voltage 250V and rated current 16A is a time proportion thermostat applicable for west kitchen equipment and plastic machinery.

Parameters

Out put at 75°	Out put at 243°	Full
1~9	50~80	+

Overall Dimension

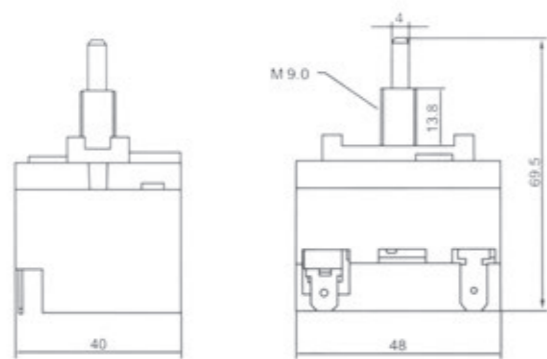

WZA-SJ

KSD-301/302/304 (Kick Type Thermostat)

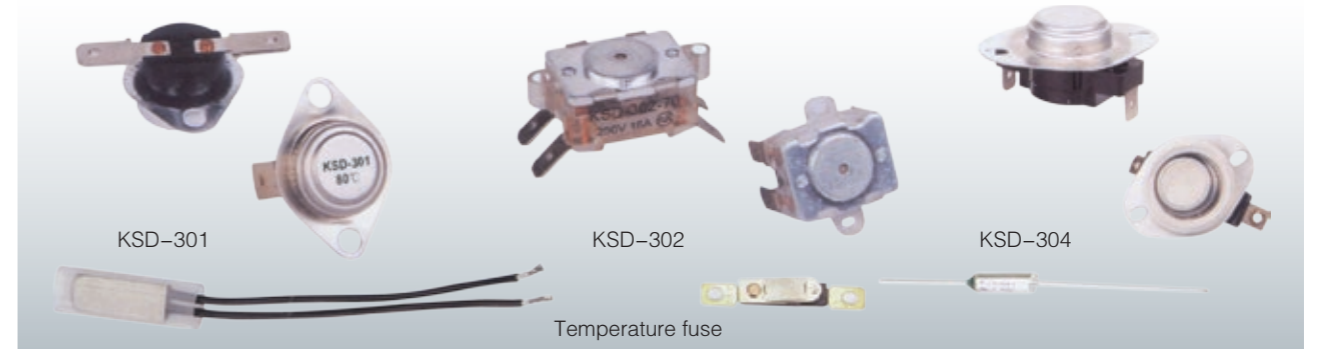

Introduction

KSD-301/302/304 Series Kick type thermostat, applicable for protective temp, limit of electric water heater and boiled water device (Temperature fuse).

Parameters

Temperature limited scope(°C)	Open point differential(°C)	Breaking differential(°C)	Start/stop differential	Rated voltage and current	
				KSD-301/302 Temperature Fuse	KSD-304
≤ 100°C	± 3°C	± 5°C	11°C	220V 10A(5A)	380V 20A
101°C ~130°C	± 3°C	± 5°C	14°C		
131°C ~150°C	± 3°C	± 5°C	17°C		