

## Non-segregated phase bus duct

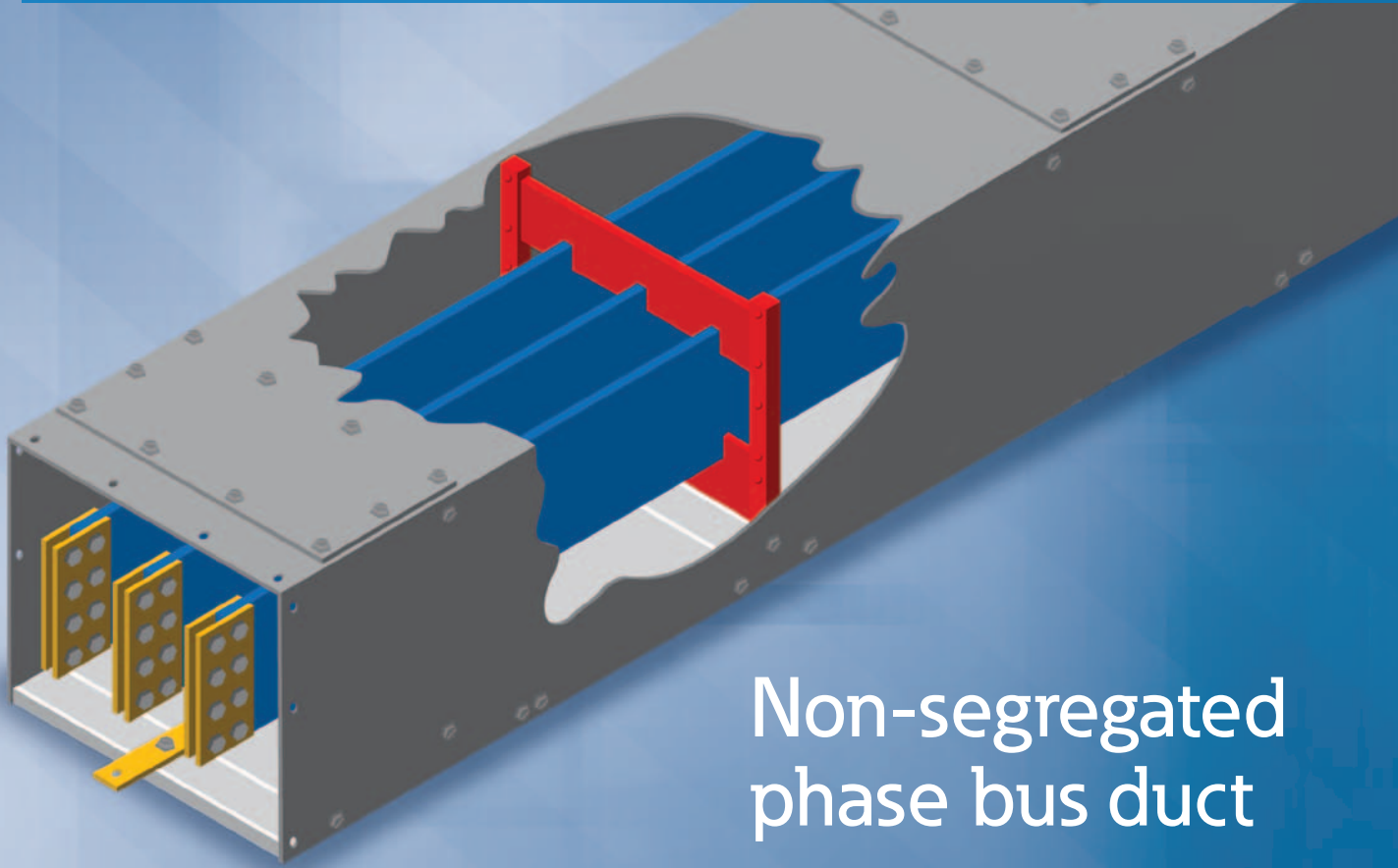

Non-segregated  
phase bus duct

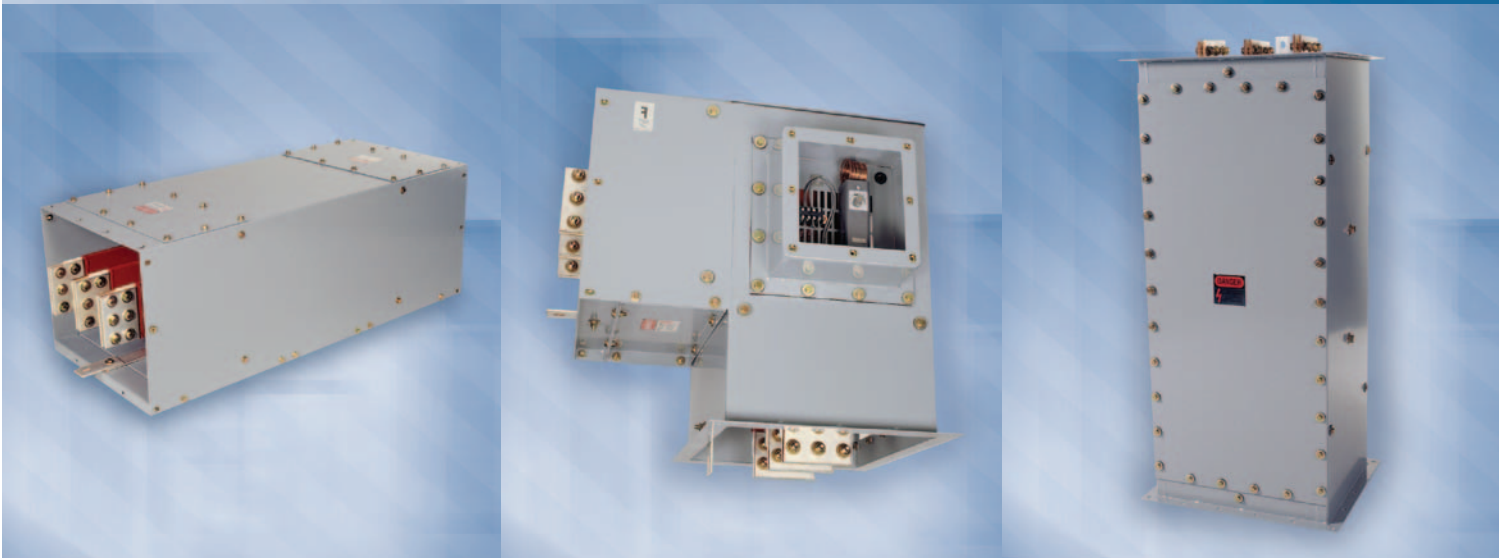

**EATON**

*Powering Business Worldwide*

# Eaton non-segregated phase bus duct

## Non-segregated phase bus duct offers a full range of products to meet many diverse applications

For over 30 years, Eaton's non-segregated phase bus duct has been designed to meet specific installation requirements for reliable power distribution. Typical of such applications are the connections from transformers to switchgear assemblies in unit substations, connections from switchgear assemblies to generators, and tie connections between switchgear assemblies. Non-segregated phase bus duct is an assembly of bus conductors with associated connections, joints and insulating supports confined within a metal enclosure without inter-phase barriers. Because of its compact dimensions, relative light weight and user-friendly design, non-segregated phase bus duct is easy to install.

## Product offering

- 1200–5000A rated continuous current
- 600V–38 kV rated maximum voltage
- 40–63 kA symmetrical short-circuit withstand
- 10–17 kV impulse withstand
- Straight sections of indoor or outdoor bus duct are available in any length in 1/8-inch increments from a 24.00-inch (609.6 mm) minimum to a 96.00-inch (2.4 m) maximum. A wide range of fittings are available for indoor and outdoor bus duct

## Product features and benefits

- Standard 11 gauge aluminum housing provides durability and product integrity; steel and stainless steel also available
- Standard finish (inside and out) is a baked-on epoxy powder coating, which provides excellent mechanical strength, is scratch resistant and resists chalking caused by ultraviolet rays
- An epoxy insulation process ensures optimum conductor protection, reducing the possibility of corona and electrical tracking
- 98% conductivity copper with all joint surfaces silver-plated to ensure maximum conductivity through the joint
- Innovative joint design allows each horizontal joint to expand and contract up to 0.50 inch (12.7 mm), ensuring a reliable installation
- Product design and manufacturing meets requirements of NEMA®, ANSI/IEEE®, ISO and CSA®; also seismic-certified for the Uniform Building Code (UBC) and California Building Code
- A full family of fittings and accessories to meet any application requirements
- High two-second short-circuit ratings optimize coordination between bus duct and power equipment
- Easy installation allows for a lower installation cost in comparison to power cable

## Bus duct capabilities

- The non-segregated phase bus duct manufacturing facility in Greenwood, SC, is able to meet your emergency or quick-ship lead-times from two days to three weeks
- Customer approval drawings can be available in two weeks or less to meet your project requirements
- Eaton's Final Field Fit program ensures accurate layout and allows for minor last minute modifications during installation
- Advanced system tools, including Bid Manager, ProDesign™, and AutoCAD®, provide quick and accurate information as well as help meet your custom requirements

## Product support

Non-segregated phase bus duct product and application support is available from a professional team of Eaton employees that includes field sales engineers, application engineers, engineering service and Greenwood bus duct product engineers.

## Additional information

*Technical Data*  
TD01702001E

*Distribution Products Catalog*  
CA08101001E

*Consulting Application Guide*  
CA08104001E

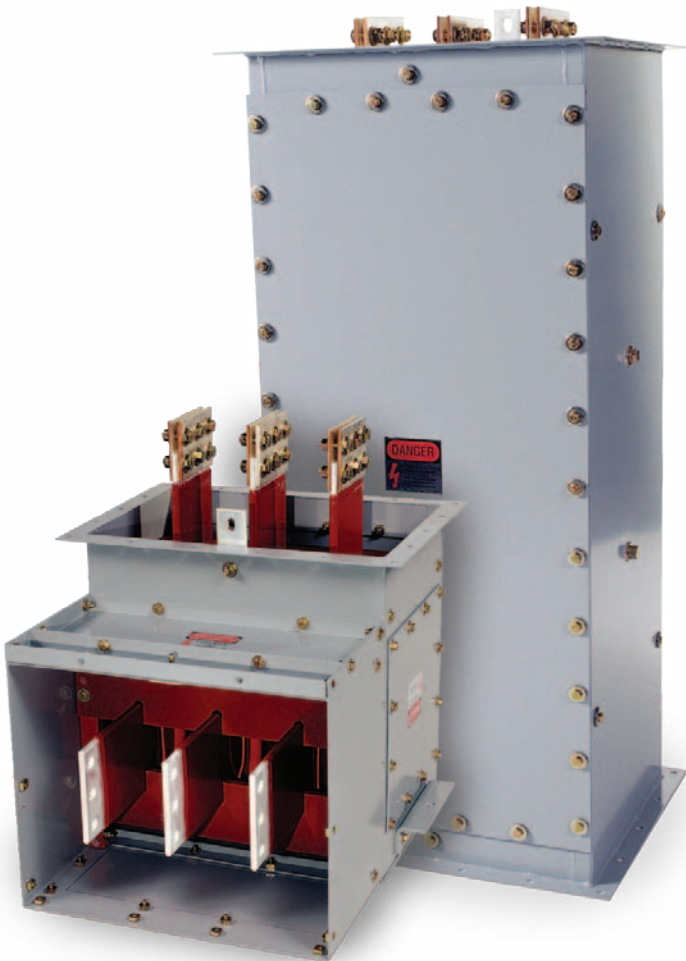

# Lightweight enclosures with built-in features for easy installation

## Housing design

Enclosures are fabricated from 11-gauge aluminum as standard. Eleven-gauge mild steel and stainless steel are available upon request. Enclosures are welded for maximum rigidity. Removable covers are secured with bolts for ease of access when making joints and subsequent periodic inspections.

Enclosures are painted with a baked-on polyester powder coat paint system resulting in a very durable finish with uniform thickness and gloss. This cosmetically pleasing finish minimizes the risk of problems in harsh environments. The standard color is ANSI-61 light gray. Special paint colors are available upon request.

The housing is designed with 0.50-inch adjustability at the joint (0.25-inch more or less than nominal). To make these adjustments, remove the two nominal position screws and loosen the two 0.375-16 bolts on the adjustable angle. The adjustable angle, collar, and busbars are slotted to allow movement. Adjustment available on horizontal joints only.

Enclosures for outdoor applications are supplied with a neoprene gasket. The gasket is applied under the collar and around the cutout of the top access cover (when provided). Rubber washers are provided with the collar hardware and top access cover hardware.

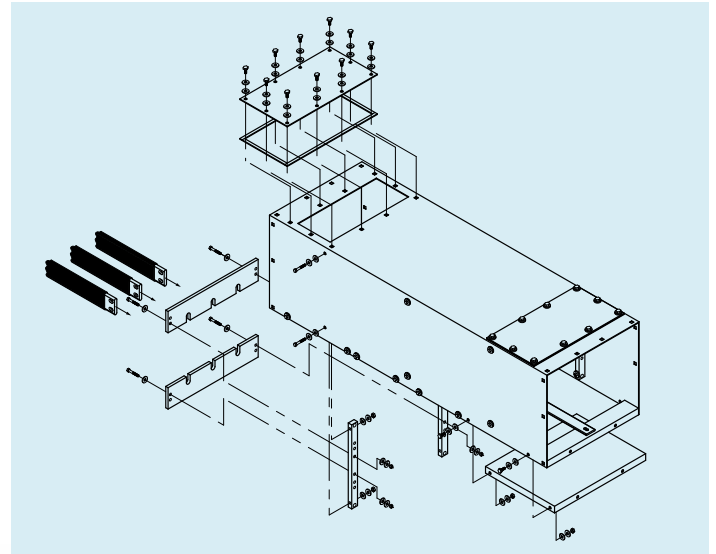

Housing Assembly

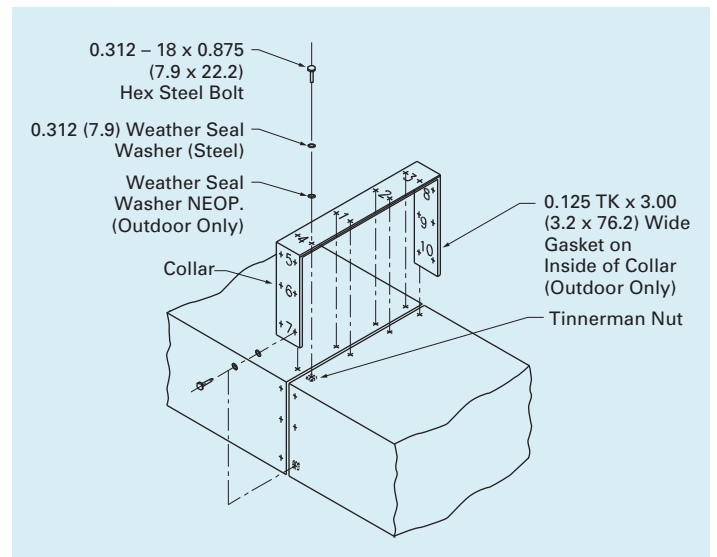

Joint Collar Assembly

# Epoxy insulation provides exceptional performance

## Busbar insulation system

Busbars are fabricated from high-strength, 98% conductivity copper. The phase and neutral bars are insulated with a Class B, 130°C, epoxy insulation applied by an automated fluidized bed process. This application insulates the conductors in a precisely defined and controlled manner to ensure a smooth, continuous, and uniform thickness.

The busbars undergo a series of pre-treatment processes, which cleans them to enhance bonding of the epoxy powder. The pre-treatment stage also helps to prevent any contamination of powder. After pre-treatment, the bars are submerged in a two-station water bath to rid them of any abundance of the chemicals used in the pre-treatment process. After the cleaning is complete, the bars are preheated uniformly in an air-circulating oven to enable the epoxy powder to melt and fuse to the busbars.

The epoxy powder is applied over the full length of the preheated bar except for the joint and contact surfaces. After the epoxy has been allowed to gel and fuse to the busbars, they enter a cure oven. This ensures that all the epoxy cross-links and hardens to the bars.

The consistent thickness and smooth surface of the epoxy provides a high-quality insulation with a 50-year life cycle. The fluidized bed process also provides excellent edge coverage to the bars. Epoxy provides optimum resistance to water absorption and chemical erosion. It has excellent dielectric strength, is flame retardant, and resists impacts that other Class B insulating material cannot withstand. Epoxy has outstanding heat transfer characteristics.



The preheated copper bars are shown prior to immersion in the epoxy powder.



All phase and neutral bars receive a coating of Class B, 130°C, epoxy insulation applied by a fluidized bed process. The copper feeder bars are shown being withdrawn from the bed and sent to a cure oven.

## Highly durable silver-plating

Silver-plating is applied to all joint and contact surfaces. Tin-plating is also available. Copper bars are silver-plated by a flashing process. Silver-plating provides an extremely durable contact surface for each splice joint.



# High short-circuit and withstand ratings

## Bar design

All conductors are 98% conductivity copper bars. Each conductor for 2400V service and above is insulated with a fluidized bed epoxy coating throughout, which reduces the possibility of corona and electrical tracking. Insulating 600V is available upon request.

The conductors are adequately separated and insulated from each other using non-hygroscopic,

track-resistant, flame-retardant polyester supports. Porcelain supports are available upon request.

Bus joints are made by solidly bolting busbars together with splice plates on each side. All joint surfaces are silver-plated as standard to ensure maximum conductivity through the joint. Tin-plating is available upon request.

After bolting, each standard joint is covered by a preformed, flame-retardant insulating boot, providing full insulation for bus conductors. These boots are easily removable for inspection of the joints at any future time.

## Copper bar only

Custom-made copper conductors are available. See *Technical Data* TD01702001E page 4 for available bar sizes.

## Available options

- Fluidized epoxy insulation
- Silver-plating
- Tin-plating
- Piercing per customer specification
- Bend per customer specification (90°–180°)

## Available Non-Segregated Bus Ratings per ANSI/IEEE Standards C37.23-1987

Rated Maximum Voltage kV rms	Rated Power Frequency Hz	Power Frequency Withstand 1 min. Dry, kV rms	Impulse Withstand (1.2 x 50 microsec) kV Peak	Rated Continuous Current Amperes	Rated Short-Time Short-Circuit Withstand Current (kA rms Symmetrical)		Rated Momentary Short-Circuit Withstand Current	
					2 sec	1 sec ①	10 Cycle ②	
							kA Peak	kA rms Asymmetrical
0.635	60	2.2	10	1200	49	69	132	78
				2000				
				3000				
				3200				
				4000				
5000								
0.635	60	2.2	10	1200	63	89	170	100.8
				2000				
				3000				
				3200				
4.76	60	19	60	1200	49	—	132	78
				2000				
				3000				
				3200				
				4000				
5000								
4.76	60	19	60	1200	63	—	170	100.8
				2000				
				3000				
				3200				
8.25	60	36	95	1200	41	—	111	66
				2000				
				3000				
				3200				
				4000				
5000								
8.25	60	36	95	1200	63	—	170	100.8
				2000				
				3000				
				3200				
15	60	36	95	1200	48	—	130	77
				2000				
				3000				
				3200				
				4000				
5000								
15	60	36	95	1200	63	—	170	100.8
				2000				
				3000				
				3200				
27	60	60	125	1200	40	—	108	64
				2000				
38	60	80	170	1200	40	—	104	64
				2000				

① This is a value calculated from two second short-circuit current withstand rating based on relationship  $I^2t = \text{constant}$ .

② For 600V application, four-cycle momentary current withstand rating up to 158 kA peak (98.8 kA rms asymmetrical) is also available.

# A complete line of accessories for indoor and outdoor applications

## Accessories

### Flange

Connects non-segregated phase bus to medium voltage switchgear, medium voltage motor control centers, low voltage switchgear, low voltage switchboards, and low voltage motor control centers

### Phase transposition

Can be provided within the bus run system to align phasing of terminal equipment at two ends

### Elbow

Used to turn the bus run by 90°

### Tee

Used for three-directional connections

### Offset

Used to avoid obstacles

### Expansion joint

Provided in runs longer than 50 feet to accommodate thermal expansion of bus conductors with respect to the enclosure

### Wall flange

Provided when a bus run passes through a wall or floor

### Transformer throat

Used when making connections to transformers; includes a matching flange and required number of flexible copper braids for connections to transformer bushing terminal pads

### Cable tap box

Used for cable connections to the bus run

### Bushing box

Used to connect bus duct to an outside source such as a power station or cable connection located outdoors

### Horizontal hanger

Provided on indoor runs and attached to the existing building structure through the use of 5/8-inch diameter drop rods

### Column support

Used to support outdoor runs; normally consists of a single structural column with a crossbeam, which is bolted to brackets provided on the bus housing (Eaton provides the brackets only)

### Space heater

Provided on outdoor bus runs for use with customer-supplied 120 Vac (or 240 Vac) power supply; energized continuously, or optional thermostat control available

### Seismic application

Bus run assemblies are designed to meet Uniform Building Code® (UBC) and California Building Code Title 24 for Seismic Zones 4.3.2a.2b.1 and 0; complete guidelines for proper supports are provided on each seismic-specified order

### Thermostats

Two options available for control of space heaters: fixed or non-adjustable to provide continuous heat, and adjustable for controlled heat up to 110°F

### Vapor barriers

Provided as specified to prevent moisture and air from passing through the bus duct

### Fire barriers

Come with vapor barriers and use fire-stop foam to provide 1-, 2- or 3-hour fire barrier

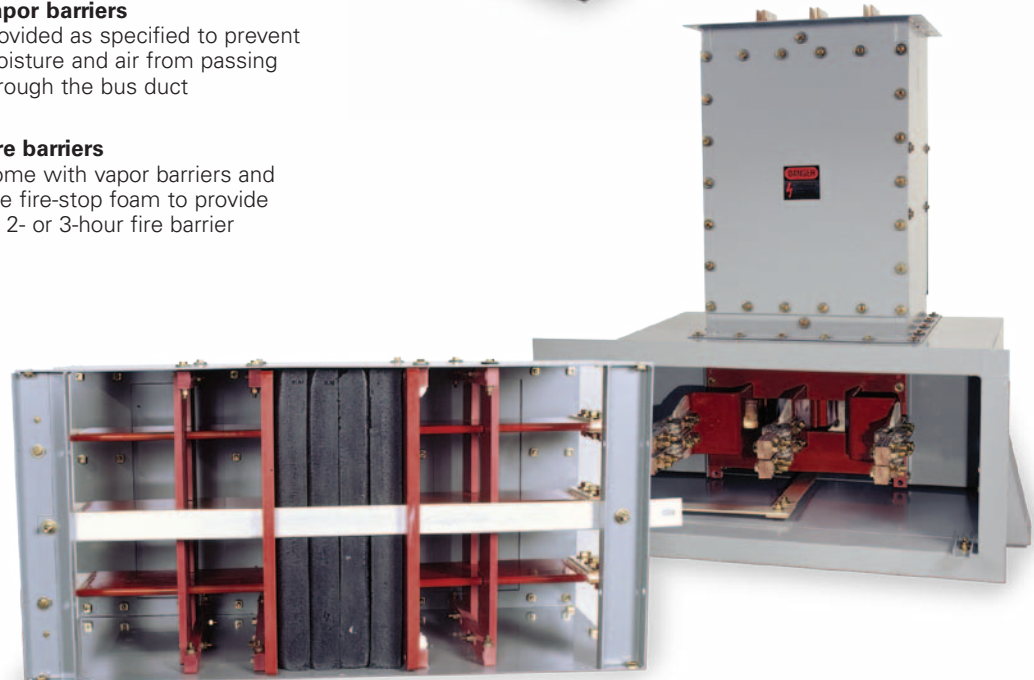
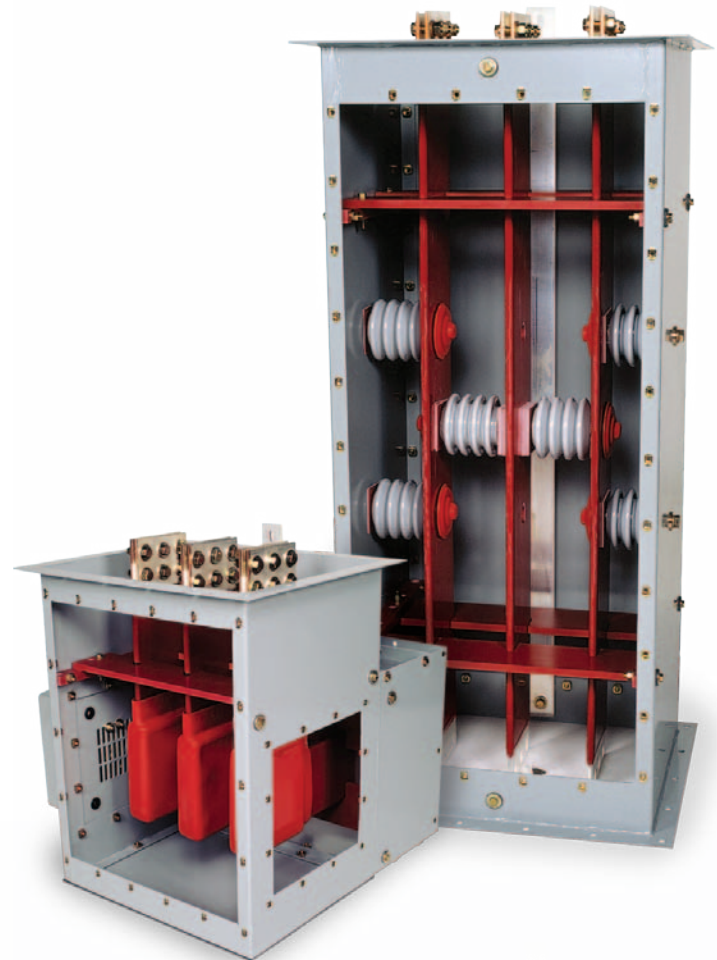

Configurable in multiple combinations to complete any system  
Engineered-to-order and custom-built to meet customer-driven solutions

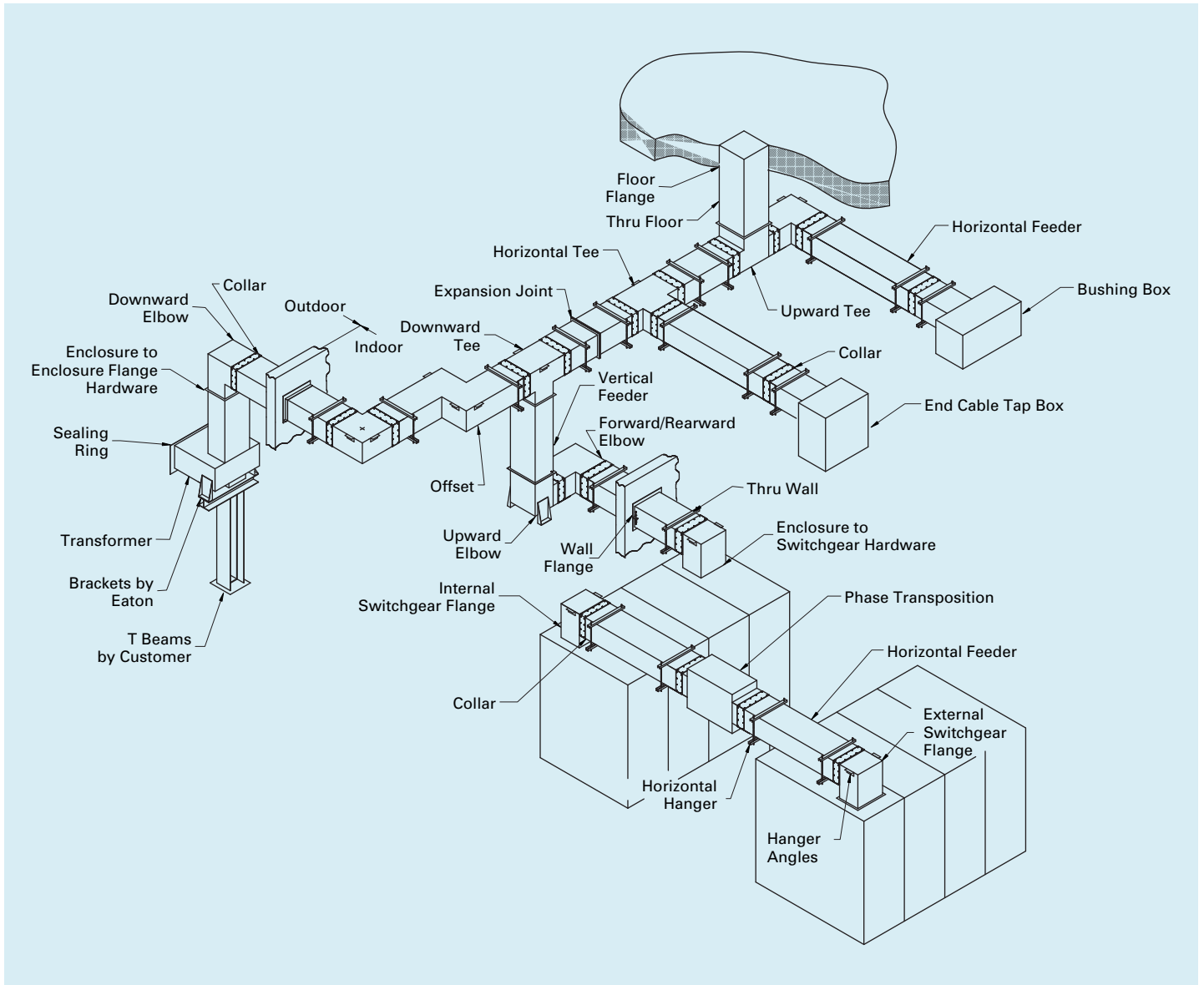

Eaton's Electrical Sector is a global leader in power distribution, power quality, control and automation, and monitoring products. When combined with Eaton's full-scale engineering services, these products provide customer-driven PowerChain™ solutions to serve the power system needs of the data center, industrial, institutional, public sector, utility, commercial, residential, IT, mission critical, alternative energy and OEM markets worldwide.

PowerChain solutions help enterprises achieve sustainable and competitive advantages through proactive management of the power system as a strategic, integrated asset throughout its life cycle, resulting in enhanced safety, greater reliability and energy efficiency. For more information, visit [www.eaton.com/electrical](http://www.eaton.com/electrical).

**Eaton Corporation**  
Electrical Sector  
1111 Superior Ave.  
Cleveland, OH 44114  
United States  
877-ETN-CARE (877-386-2273)  
[Eaton.com](http://Eaton.com)

© 2010 Eaton Corporation  
All Rights Reserved  
Printed in USA  
Publication No. BR01702001E / Z10442  
November 2010



**PowerChain  
Management®**

PowerChain Management is a registered trademark of Eaton Corporation.

All other trademarks are property of their respective owners.



*Powering Business Worldwide*