

Metering Devices, Protective Relays, Software and Connectivity

9.1	Monitoring Software	
	Power Xpert Insight	V3-T9-2
9.2	Metering Devices	
	Product Overview	V3-T9-6
	Power Xpert Meter 4000/6000/8000 Series	V3-T9-13
	Power Xpert Meter 2000 Series	V3-T9-26
	IQ 250/260 Series Electronic Power Meters	V3-T9-35
	IQ 130/140/150 Series Electronic Power Meters.	V3-T9-41
	IQ 150S/250S Self-Enclosed Electronic Meters	V3-T9-46
	IQ 35M	V3-T9-51
	IQ Analyzer 6400/6600 Series.	V3-T9-54
	IQ DP-4000 Series.	V3-T9-62
	Power Xpert Multi-Point Meter	V3-T9-68
	PM3 Monitoring and Metering Module.	V3-T9-80
	Current Transformers (CTs)	V3-T9-81
	Clamp-On Current Transformers	V3-T9-90
	IQ Flange.	V3-T9-93
	Enclosed Meters.	V3-T9-95
9.3	Protective Relays	
	Product Selection Guide	V3-T9-117
	Digitrip 3000	V3-T9-123
	EDR-3000 Feeder Protection.	V3-T9-133
	EDR-5000 Distribution Protection Relay	V3-T9-142
	FP-5000 Feeder Protection	V3-T9-155
	MP-3000 Motor Protection	V3-T9-163
	MP-4000 Motor Protection	V3-T9-173
	EMR-3000 Motor Protection Relay	V3-T9-179
	EMR-4000 Motor Protection Relay	V3-T9-191
	EMR-5000 Motor Protection Relay	V3-T9-204
	ETR-4000 Transformer Protection Relay	V3-T9-216
	ETR-5000 Transformer Protection Relay	V3-T9-228
	EGR-5000 Generation Protection Relay	V3-T9-241
	Ground Fault Relay	V3-T9-254
	Universal RTD Module.	V3-T9-257
9.4	Connectivity Options	
	Power Xpert Gateway	V3-T9-261
	Power Xpert Ethernet Switches	V3-T9-270
	mMINT	V3-T9-274
	IPONI.	V3-T9-276
	DPONI.	V3-T9-277
	MPONI	V3-T9-278
	I/O Devices Digital Input Module (DIM)	V3-T9-279
	Addressable Relay II	V3-T9-281
	Breaker Interface Module II (BIM II)	V3-T9-283

Revision notes

Volume 3—Power Distribution and Control Assemblies, CA08100004E

Tab 9—Metering Devices, Protective Relays, Software and Connectivity

Revision date	Section	Change page(s)	Description
05/04/2017	9.2	V3-T9-6 to V3-T9-116	Content edits to entire section; IQ 230 Meters and IQ Energy Sentinel product deletion.



Powering Business Worldwide

Power Xpert Insight



Contents

Description	Page
Power Xpert Insight	
Features	V3-T9-3
Product Selection	V3-T9-4
Technical Data and Specifications	V3-T9-5



Power Xpert Insight

Product Description

Power Xpert Insight® is a power and energy monitoring system that is amazingly simple—simple to install, simple to use, simple to add new devices and simple to obtain the information needed to make important operating decisions every day. Power Xpert Insight provides the insight into your customers’ electrical system and takes the complexity out of power and energy management.

A Web-based software, Power Xpert Insight is designed to be quick to install and configure so that systems can be up and running quickly. Developed after extensive study and testing with users, the software allows customers to view only the device information that they want to see, simplify alarm management, view energy usage and demand data, compare and trend data, and view a one-line representation of their electrical system.

Power Xpert Insight provides the energy and power information you need to:

- Keep the lights on with real-time, actionable alarms across desktop and mobile
- Save money and energy with easy-to-use and share energy reports
- Stay up to speed on your most critical devices with adjustable dashboards
- Drill into problems quickly with powerful graphics and detailed data
- Understand current issues and plan for future investments using trends and visualizations

Features

Energy

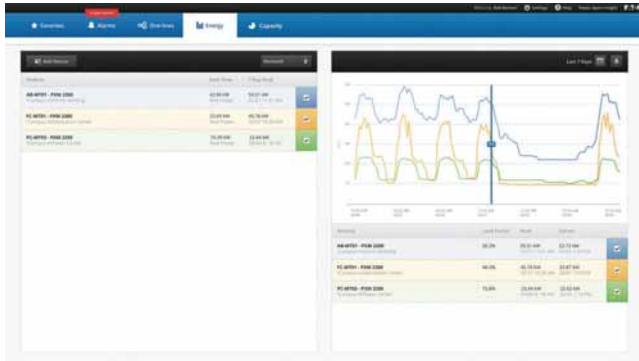

- View energy usage and demand
- Select the desired devices and time range, 24 hours to a custom range
- Choose the type of graph that best suits; line or stacked bar chart
- Move the cursor over the graph to view detailed data
- Export data to a CSV-format file
- Expand to the Trend Viewer for additional information
- Energy usage is automatically summed for the devices shown in the table

Capacity

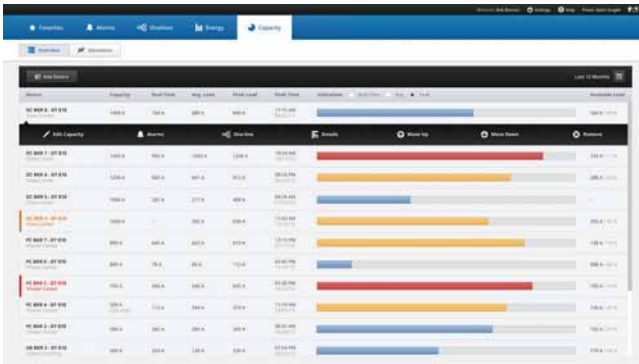

- Benchmark capacity usage in real-time to determine tripping points and avoid downtime
- Custom trigger thresholds for cautionary and critical levels support all types of electrical environments and changing needs
- Simulate and trend with line graphics load additions prior to device installation to avoid tripping and downtime
- Forecast, budget and plan capacity requirements
- Proactively predict overall electrical system performance by modeling capabilities

Alarms

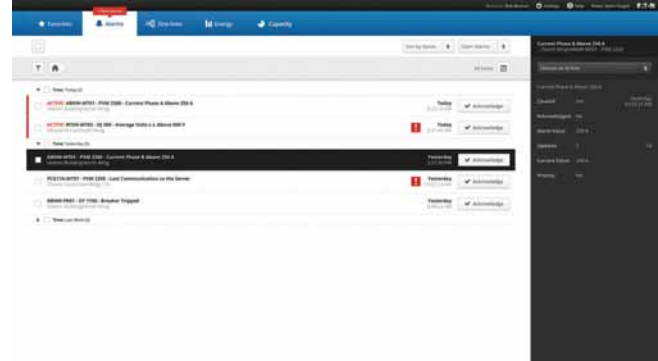

- View color-coded alarms on one page (Black = Normal, Red = Alarm, Orange = Loss of Communication)
- Sort alarms by Time, Device or Priority for a specified time range, view by Alarm Status
- Acknowledge Alarms by individual device or group together
- Open the Alarm Pop Out to view additional data and add notes
- Export alarm history to a CSV-format file

Favorites Dashboard

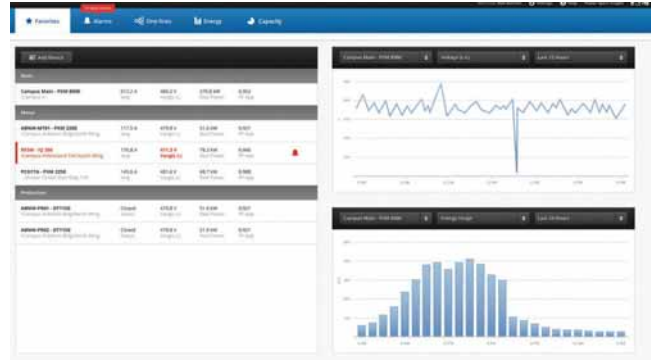

- Each user can create a unique dashboard to focus on the devices or systems that they are interested in
- Devices are displayed by device type (Main, Meter, Protection) and populate the top 4 channels for that device
- Alarm color-coding is automatically propagated across pages
- A quick Trend Graph and Energy Graph are also displayed for a selected device and channel over a time range up to 24 hours
- Quickly add or remove devices from the Favorites dashboard

One-lines

9

- Build an electrical one-line representation of the system with device widgets and the symbols library
- Drag-and-drop devices, lines, symbols where needed, add text boxes. Easily updated when devices are removed or added to service
- The top 4 device channels are automatically populated on the device widgets and alarm color-coding carries through on the one-lines
- Upload a unique background image
- Use the Device Tree to set up the one-line structure

Offline Configuration

- Power Xpert Insight provides the ability to completely configure a system in advance. The more you know about the final system, the more complete the offline configuration process will be
- Configure Power Xpert Insight in advance using an Excel® spreadsheet (template available at Eaton.com/pxi)
- Upload the spreadsheet to an offline Power Xpert Insight system
- Set up one-line graphics in the offline Power Xpert Insight system
- Extract the entire system configuration
- Upload the configuration into the target system when ready and connect when the devices are online

Product Selection**Power Xpert Insight**

Description	Catalog Number
PXI for up to 10 device connections	PXI-A
PXI for up to 25 device connections	PXI-B
PXI for up to 50 device connections	PXI-C
PXI for up to 100 device connections	PXI-D
PXI for up to 200 device connections	PXI-E

PXI Device Count Upgrades

Description	Catalog Number
PXI 10 to 25 upgrade	PXI-A2B
PXI 10 to 50 upgrade	PXI-A2C
PXI 10 to 100 upgrade	PXI-A2D
PXI 10 to 200 upgrade	PXI-A2E
PXI 25 to 50 upgrade	PXI-B2C
PXI 25 to 100 upgrade	PXI-B2D
PXI 25 to 200 upgrade	PXI-B2E
PXI 50 to 100 upgrade	PXI-C2D
PXI 50 to 200 upgrade	PXI-C2E
PXI 100 to 200 upgrade	PXI-D2E

Service Packs

Description	Catalog Number
Power Xpert 1-day startup service pack	PX-1S
Power Xpert 2-day startup service pack	PX-2S
Power Xpert 5-day startup service pack	PX-5S

Technical Data and Specifications

Hardware Requirements

Power Xpert Insight requires a server-class machine with the following minimum hardware specifications:

Hardware	Specification
Processor	Quad core
Memory	16 GB
Disk space required for application	100 GB—5 years estimated data storage
Disk space required for database	A typical database will grow to 2 GB within a year. If you have a large number of devices, reserve additional storage space
Video resolution	1920 by 1080 pixels

Software Requirements

Supported Operating Systems

Software	Specification
Server	Windows® Server 2008 R2, Standard and Enterprise, SP1 Windows Server 2012 Standard and Datacenter
Client	Windows 7 Professional, Ultimate or Enterprise, x64, SP1 Windows 8 Professional and Enterprise, x64
Supported versions of Microsoft® SQL Server	
SQL Server 2008 R2 Standard (and Standard for Small Business) SP2	
SQL Server 2008 R2 Enterprise	
SQL Server 2012 Express with Advanced Services, Standard, Enterprise, Enterprise Core and Business Intelligence	

Note: If you do not have one of the above versions installed, Power Xpert Insight will install SQL Server 2012 Express with Advanced Services.

Supported Web Browsers

- Microsoft Internet Explorer® (IE) 9, 10 or 11
- Google Chrome™
- Firefox®
- Other browsers (such as Opera and Safari®) that support Silverlight® may also work, but are not officially supported by Eaton

Metering Products Family



Contents

<i>Description</i>	<i>Page</i>
Metering Products Family	
Power Xpert Meter 4000/6000/8000 Series	V3-T9-13
Power Xpert Meter 2000 Series	V3-T9-26
IQ 250/260 Series Electronic Power Meters	V3-T9-35
IQ 130/140/150 Series Electronic Power Meters	V3-T9-41
IQ 150S/250S Self-Enclosed Electronic Meters	V3-T9-46
IQ 35M	V3-T9-51
IQ Analyzer 6400/6600 Series	V3-T9-54
IQ DP-4000 Series	V3-T9-62
Power Xpert Multi-Point Meter	V3-T9-68
PM3 Monitoring and Metering Module	V3-T9-80
Current Transformers (CTs)	V3-T9-81
Clamp-On Current Transformers	V3-T9-90
IQ Flange	V3-T9-93
Panel Mounting Adapter Kit	V3-T9-94
Enclosed Meters	V3-T9-95

Product Overview

Eaton’s metering products provide solutions needed to monitor and manage all aspects of an electrical distribution system.

When greater reliability, increased productivity and significant cost savings are called for to remain competitive in today’s market, Eaton’s metering products fit the bill. These innovative meters and communications systems, along with Power Management software, make it possible to successfully take control of the electrical distribution system.

Power Xpert Meters

Power Xpert Meters are the benchmark for intelligent Web-enabled top-quality metering devices for the power system. Power Xpert Meters provide measurement of the critical elements found in the power system, whether that be voltage, power, current, transients, harmonics or even time. Power Xpert Meters provide Web-enabled communications for use with the Power Xpert Insight. All Power Xpert Meters provide a standard communications protocol for easy integration into other systems.

Features and Benefits

Greater Reliability

Eaton’s metering products give the ability to receive an early warning of potential problems, eliminate unnecessary trips, isolate faults to ensure minimum downtime and shed or equalize loads while a problem is being corrected.

Increased Productivity

Equipment downtime resulting from voltage or frequency variations can be very costly to an operation. Monitoring power quality with Eaton’s metering products throughout the electrical distribution system provides data to identify, isolate and correct problems quickly and efficiently.

Reduced Energy and Operating Costs

When we think about meters and power quality, the common thread throughout the basket of solutions is information. Collecting, monitoring and managing data from the electrical distribution system can help reduce costs for those facilities prepared to define and analyze present electrical energy usage levels and patterns. Data provided by Eaton’s metering products comprise the data for verifying utility bills for energy management and lowering operating costs. Deregulation in some geographical locations permits energy users to select a utility provider and negotiate rate structures. For large users with heavy utility bills, this may be an incentive to verify the utility bill, identify an opportunity for savings, negotiate a better utility rate and apply the savings directly to the bottom line. Users are also empowered to decrease energy consumption, thereby lowering peak demand charges and decreasing operating costs.

When an Eaton meter is used with Eaton trip units and relays incorporating built-in metering capabilities, the entire electrical distribution system can be cost-effectively managed.

Eaton is an industry leader offering a complete integrated solution to oversee your entire electrical distribution system. As a global manufacturer of low and medium voltage electrical distribution system equipment and components, Eaton is an experienced innovator of metering products that incorporate cutting-edge technology. These innovations result from our scientific and engineering expertise, physical resources and the ongoing R&D programs at our technology centers.

Product Selection Guide

Metering Selection Chart

Power Xpert Meter 4000/6000/8000 Series



Power Xpert Meter 2000 Series



IQ 250/260 Series



Device Name
Accessories
See Page V3-T9-90

Section Page Number

V3-T9-13

V3-T9-26

V3-T9-35

Electrical Parameters

Volts	0.1% of RV + 0.02% FS	0.1% of RV	0.1% of RV
Amperes	0.05% of RV + 0.01% FS	0.1% of RV	0.1% of RV
Current range (% of nominal)	0.005–20A (400%)	0.1–200%	0.1–200%
Watts	0.1% of RV + 0.0025% FS	0.2% of RV	0.2% of RV
VARs	0.1% of RV + 0.0025% FS	0.2% of RV	0.2% of RV
VA	0.1% of RV + 0.0025% FS	0.2% of RV	0.2% of RV
PF-apparent	0.1%	0.2% of RV	0.2% of RV
PF-displacement	0.1%	—	—
Frequency	±0.01 Hz	±0.03 Hz	±0.03 Hz
THD-voltage	127th	40th ②③④⑤	40th ⑥
THD-current	127th	40th ②③④⑤	40th ⑥
Wathours	±0.2% per ANSI C12.20 0.2 Class ①	±0.2% per ANSI C12.20 0.2 Class ①	±0.2% per ANSI C12.20 0.2 Class ①
VAR-hours	±0.2% per ANSI C12.20 0.2 Class ①	±0.2% per ANSI C12.20 0.2 Class ①	±0.2% per ANSI C12.20 0.2 Class ①
VA-hours	±0.2% per ANSI C12.20 0.2 Class ①	±0.2% per ANSI C12.20 0.2 Class ①	±0.2% per ANSI C12.20 0.2 Class ①
Ampere-demand	0.05% of RV + 0.01% FS	±0.1% per ANSI C12.20 0.2 Class	±0.1% per ANSI C12.20 0.2 Class
Watt-demand	±0.2% per ANSI C12.20 0.2 Class ①	±0.2% per ANSI C12.20 0.2 Class ①	±0.2% per ANSI C12.20 0.2 Class ①
VAR-demand	±0.2% per ANSI C12.20 0.2 Class ①	±0.2% per ANSI C12.20 0.2 Class ①	±0.2% per ANSI C12.20 0.2 Class ①
VA-demand	±0.2% per ANSI C12.20 0.2 Class ①	±0.2% per ANSI C12.20 0.2 Class ①	±0.2% per ANSI C12.20 0.2 Class ①
Revenue accuracy	±0.2% per ANSI C12.20 0.2 Class ①	ANSI C12.20 (0.2%)	ANSI C12.20 (0.2%)
Individual ampere harmonics	85th ⑦	40th ③④⑤	—
Individual voltage harmonics	85th ⑦	40th ③④⑤	—
Interharmonics	Yes	—	—

Minimum and/or Maximum Values

Volts	L-L, L-N, N-G, VAUX L-L	L-L, L-N	L-L, L-N
Current	A, B, C, N, G	A, B, C, N	A, B, C
Power	Watt, VAR, VA	Watt, VAR, VA	Watt, VAR, VA
Power Factor	Apparent/displacement	Apparent	Apparent
Frequency	Hertz	Hertz	Hertz
THD	Amperes/volts (L-L, L-N, AUX L-L)	Amperes/volts ②③④⑤	Amperes/volts ⑥
Demand values	kW, kVAR, kVA, amperes	kW, kVAR, kVA, amperes	kW, kVAR, kVA, amperes
Trend analysis	2 / 4 ⑧ / 8 ⑨ GB	256 / 512 ② / 768 ③④⑤ MB	128 KB ⑩
Event logging	2 / 4 ⑧ / 8 ⑨ GB	100,000 alarms/events with timestamp	⑩
Disturbance recording	2 / 4 ⑧ / 8 ⑨ GB 60 cycles per event	768 MB ④⑤ up to 64 cycles per event ④⑤	—

Notes

- ① Under typical operating conditions.
- ② PXM 2260 only.
- ③ PXM 2270 only.
- ④ PXM 2280 only.
- ⑤ PXM 2290 only.
- ⑥ IQ 260 only.

- ⑦ Individual values reported to 85th harmonic; anti-alias filtering prevents higher frequencies from distorting readings (see IEC 61000-4-7).
- ⑧ PMX 6000 only.
- ⑨ PXM 8000 only.
- ⑩ Optional.
- ⑪ At computer only.

Legend: PG = Programmable

- FS = Full scale
- RV = Read value
- Auxiliary voltage (optional) = Provides three additional voltage inputs to the meter: Va2, Vb2, Vc2.
- Interharmonics = Power Xpert Meter 6000/8000 supported.

Metering Selection Chart, continued

Power Xpert Meter 4000/6000/8000 Series



Power Xpert Meter 2000 Series



IQ 250/260 Series



Device Name
Accessories
See Page V3-T9-90

Section Page Number

V3-T9-13

V3-T9-26

V3-T9-35

Other Features

Storage	2 / 4 ^① / 8 ^② GB	256 / 512 ^③ / 768 ^④ MB Standard	128 KB for logging, up to 8 parameters every 15 minutes for 30 days
PG output relays	5 maximum	Optional (2) Form C, 5A or (4) Form A, 120 mA	Optional (2) Form C, 5A or (4) Form A, 120 mA
PG analog outputs	—	Optional (4) 4–20 mA or (4) 0–1 mA	Optional (4) 4–20 mA or (4) 0–1 mA
Discrete contact inputs	8	Optional (2) or (4)	Optional (2) or (4)
Analog inputs	—	—	—
Synch-input kW utility	Via status input	Via end of interval pulse with optional digital inputs	Via end of interval pulse with optional digital inputs
Auxiliary voltage ^⑤	Yes	—	—
kWh pulse initiator	Yes	Yes	Yes
Waveform display	Local/computer	^⑥	—
Waveform capture, samples/cycle	Yes, 512 (4096 oversampling)	Yes, up to 64 ^⑦ , up to 512 ^⑧	—
Frequency distribution display	—	—	—
Display type	LCD ^⑨	Red LED	Red LED
Display lines/character	Color graphic	3 lines, 4 characters	3 lines, 4 characters
Display character height	—	0.56 (14.2) H	0.56 (14.2) H
Communications	Serial: Modbus RTU, Modbus ASCII ^⑩ Network: Modbus TCP, Ethernet TCP/IP, HTTP, SNMP, SMTP, FTP, DNP 3.0	Serial: Modbus RTU, Modbus ASCII, DNP 3.0 Network: Modbus TCP, BACnet/IP, Ethernet TCP/IP, HTTP, HTTPS, SNMP, SMTP, ^⑦ ^⑧ Waveform FTP	Serial: Modbus RTU, Modbus ASCII, DNP 3.0 Network: Modbus TCP via Power Xpert Gateway
Setup configuration	Via Web browser	Via Web browser/display	Via configuration software/display
Dimensions	Refer to TD02601007E	Refer to TD02601017E	Refer to TD02601016E
Operating temperature range	–20° to 60°C display unit –20° to 70°C meter base unit	–20° to 70°C	–20° to 70°C
Reference literature	TD02601007E	TD02601017E	TD02601016E

Notes

- ① PXM 6000 only.
- ② PXM 8000 only.
- ③ PXM 2260 only.
- ④ PXM 2270 only.
- ⑤ The auxiliary voltage option adds three additional voltage input channels to Power Xpert Meters.
- ⑥ At computer only.
- ⑦ PXM 2280 only.
- ⑧ PXM 2290 only.
- ⑨ Optional

- Legend:** PG = Programmable
FS = Full scale
RV = Read value
- Auxiliary voltage (optional) = Provides three additional voltage inputs to the meter: Va2, Vb2, Vc2.
- Interharmonics = Power Xpert Meter 6000/8000 supported.

Metering Selection Chart, continued

IQ 130/140/150 Series



IQ 150S/250S Series



IQ 35M Series



Device Name
Accessories
See Page V3-T9-90

Section Page Number

V3-T9-41

V3-T9-46

V3-T9-51

Electrical Parameters

Volts	±0.25% of RV	0.1% of RV	0.4% +0.015% per °C deviation from 25°C
Amperes	±0.25% of RV	0.1% of RV	0.4% (5–100%), 0.8% (1–5%) +0.015% per °C from 25°C
Current range (% of nominal)	0.1–200%	0.1–200%	1–120%
Watts	0.5% of RV ①	0.2% of RV	0.5% per ANSI C12.20 and IEC 62053-22 Class 0.5S
VARs	0.5% of RV ①	0.2% of RV	2.0% per IEC 62053-23 Class 2
VA	0.5% of RV ①	0.2% of RV	Calculated: vector sum of watts and VARs
PF-apparent	0.5% of RV ①	0.2% of RV	Calculated: Watts / VAs
PF-displacement	—	—	—
Frequency	±0.03% Hz ①	±0.03 Hz	±0.02 Hz
THD-voltage	—	—	—
THD-current	—	—	—
Watt-hours	±0.5% per ANSI C12.20 0.5 Class ②	±0.2% per ANSI C12.20 0.2 Class	0.5% per ANSI C12.20 and IEC 62053-22 Class 0.5S
Var-hours	±0.5% per ANSI C12.20 0.5 Class ②	±0.2% per ANSI C12.20 0.2 Class	±2.0% per IEC 62053-23 Class 2
VA-hours	±0.5% per ANSI C12.20 0.5 Class ②	±0.2% per ANSI C12.20 0.2 Class	—
Ampere-demand	±0.5% per ANSI C12.20 0.5 Class ②	±0.1% per ANSI C12.20 0.2 Class	—
Watt-demand	±0.5% per ANSI C12.20 0.5 Class ②	±0.2% per ANSI C12.20 0.2 Class	0.5% per ANSI C12.20 and IEC 62053-22 Class 0.5S
VAR-demand	±0.5% per ANSI C12.20 0.5 Class ②	±0.2% per ANSI C12.20 0.2 Class	2.0% per IEC 62053-23 Class 2
VA-demand	±0.5% per ANSI C12.20 0.5 Class ②	±0.2% per ANSI C12.20 0.2 Class	Calculated: vector sum of watts and VARs
Revenue accuracy	ANSI C12.20 (0.5%)	ANSI C12.20 (0.2%)	0.5% per ANSI C12.20 and IEC 62053-22 Class 0.5S
Individual ampere harmonics	—	—	—
Individual voltage harmonics	—	—	—
Interharmonics	—	—	—

Minimum and/or Maximum Values

Volts	L-L, L-N	L-L, L-N	—
Current	A, B, C	A, B, C	—
Power	Watt, VAR, VA	Watt, VAR, VA	—
Power factor	Apparent ①	Apparent	Apparent (low alert)
Frequency	Hertz ①	Hertz	Hertz (out of range alert)
THD	Ampere/Volts	—	—
Demand values	kW, kVAR, kVA, amperes ①	kW, kVAR, kVA, amperes	kW, kVAR, kVA; Maximum kW, kVAR, kVA
Trend analysis	③	2 MB ⑤	—
Event logging	③	2 MB ⑤	Logging on demand interval or Modbus command ④
Disturbance recording	—	—	—

Notes

- ① IQ 140 and IQ 150.
- ② IQ 150 only.
- ③ At computer only.
- ④ Optional.
- ⑤ IQ 250S only.

Legend: PG = Programmable
FS = Full scale
RV = Read value

Metering Selection Chart, continued

IQ 130/140/150 Series



IQ 150S/250S Series



IQ 35M Series



Device Name
Accessories
See Page V3-T9-90

Section Page Number

V3-T9-41

V3-T9-46

V3-T9-51

Other Features

Storage	—	2 MB ^②	10 registers (16 bit) by 5760 entries each (115 KB) ^①
PG output relays	—	—	—
PG analog outputs	—	—	—
Discrete contact inputs	—	—	2 pulse inputs with BACnet
Analog inputs	—	—	—
Synch-input kW Utility	—	—	Optional demand synchronization via Modbus
Auxiliary voltage ^③	—	—	—
kWh pulse initiator	^①	Yes	Yes
Waveform display	—	—	—
Waveform capture	—	—	—
Frequency distribution display	—	—	—
Display type	Red LED	Red LED	Backlit LCD
Display lines/character	3 lines, 4 characters	3 lines, 4 characters	2 lines by 5 characters ea (full alphanumeric top row)
Display character height	0.56 (14.2) H	0.56 (14.2) H	7.5 mm
Communications	Serial: Modbus RTU, Modbus ASCII ^① Network: Modbus TCP ^①	Serial: Modbus RTU, Modbus ASCII, DNP 3.0 Network: Modbus TCP, wired or wireless	Serial: Modbus RTU ^① , BACnet MS/TP ^① Network: Modbus TCP via Power Xpert Gateway
Setup configuration	Via configuration software/display	Via configuration software/display	Via display/configuration software
Dimensions	4.85 (123.2) H x 4.85 (123.2) W x 4.97 (126.2) D	7.90 (200.7) H x 7.50 (190.5) W x 3.10 (78.7) D	3.60 (91.4) H x 4.20 (106.7) W x 2.30 (58.4) D
Operating temperature range	–20 to 70°C	–20 to 70°C	–20 to 70°C
Reference literature	TD02601015E	TD02601019E	TD02601015E

Notes

- ^① Optional.
- ^② IQ 250S only.
- ^③ The auxiliary voltage option adds three additional voltage input channels to Power Xpert Meters.

Legend: PG = Programmable
FS = Full scale
RV = Read value

Metering Selection Chart, continued

Device Name Accessories See Page V3-T9-90	IQ Analyzer 6000 Series 	IQ DP-4000 Series 	Power Xpert Multi-Point Meter 
Section Page Number	V3-T9-54	V3-T9-62	V3-T9-68



Electrical Parameters			
Volts	±0.2% FS ①	±0.3% FS	±0.2% RV
Amperes	±0.2% FS ①	±0.3% FS	±0.2% RV
Current range (% of nominal)	3–800%	10–250%	—
Watts	0.4% FS, 6 RV ②	±0.6% FS	±0.5% RV
VARs	0.4% FS, 6 RV ③	±0.6% FS	±0.5% RV
VA	0.4% FS, 6 RV ②	±0.6% FS	±0.5% RV
PF-apparent	0.8% FS ①	±1.0% FS	±0.5% RV
PF-displacement	0.8% FS ①	±1.0% FS	—
Frequency	0.04% ① or 0.01 Hz	±0.17% FS	±0.1 Hz
THD-voltage	50th	31st	—
THD-current	50th	31st	—
Watt-hours	0.5% RV ②	±0.6% FS	±0.5% per ANSI C12.20 0.5 class
Var-hours	1% RV ③	±0.6% FS	±0.5% per ANSI C12.20 0.5 class
VA-hours	0.5% RV ②	±0.6% FS	±0.5% per ANSI C12.20 0.5 class
Ampere-demand	±0.2% FS ①	±0.3%	—
Watt-demand	±0.4% FS ①	±0.6%	±0.5% per ANSI C12.20 0.5 class
VAR-demand	±0.4% FS ①	±0.6%	±0.5% per ANSI C12.20 0.5 class
VA-demand	±0.4% FS ①	±0.6%	±0.5% per ANSI C12.20 0.5 class
Revenue accuracy	ANSI C12.20 (0.5%)	—	ANSI C12.20 (0.5%)
Individual ampere harmonics	50th	—	—
Individual voltage harmonics	50th	—	—
Interharmonics	—	—	—
Minimum and/or Maximum Values			
Volts	L-L, L-N	L-L, L-N	L-L, L-N
Current	A, B, C, N, G	A, B, C	A, B, C
Power	Watt, VAR, VA	Watt, VAR, VA	Watts, VAR, VA
Power factor	Apparent/displacement	Apparent/displacement	Apparent
Frequency	Hertz	Hertz	Hertz
THD	Amperes/volts	Amperes/volts	—
Demand values	All	All	Watts (Delivered & Received), Watts (Q1–Q4), VA (Q1, Q4), VA (Q2, Q3)
Trend analysis	Time/date	2 alarms	Interval data
Event logging	504 events w/timestamp	④	20 latest events and historical
Disturbance recording	10 waveform events	—	—

Notes

- ① From 3–300% of FS.
- ② At unity power factory and 5–300% of FS.
- ③ At a power factor $\leq\pm 0.5$ and 5–300% of FS.
- ④ At computer only.

Legend: PG = Programmable
 FS = Full scale
 RV = Read value

Metering Selection Chart, continued

Device Name Accessories See Page V3-T9-90	IQ Analyzer 6000 Series 	IQ DP-4000 Series 	Power Xpert Multi-Point Meter 
Section Page Number	V3-T9-54	V3-T9-62	V3-T9-68
Other Features			
Storage	90 KB	15 parameters	256 MB standard, 2 GB optional
PG output relays	(4) 10A Form C ^①	(3) 10A Form C ^②	1 standard, 8 each module ^①
PG analog outputs	(4) 0–10/4–20 mA	—	3 standard, 8 each module ^①
Discrete contact inputs	(3) + 30 Vdc differential	(1) kW Demand ^②	—
Analog inputs	(1) 0–20/4–20 mA	—	Via communications and digital input
Synch-input kW Utility	At device or via communications	At device or via communications ^②	—
Auxiliary voltage	—	—	Aggregate or main-digital output, LED output on meter modules (accuracy check)
kWh pulse initiator	Yes	Yes ^②	—
Waveform display	Local ^② /computer	—	—
Waveform capture, samples/cycle	Yes, 128	—	—
Frequency distribution display	Local ^② /computer	—	—
Display type	Graphic LCD with LED backlight	7 Segment LED	LCD color touchscreen ^①
Display lines/character	7 lines, 147 characters	1 line, 7 characters	6-inch diagonal
Display character height	Up to 7 lines	1 line	Graphics
Communications	Serial: INCOM ^③ Network: via Power Xpert Gateway ^③	Serial: INCOM ^③ Network: via Power Xpert Gateway ^③	Serial: Modbus RTU ^① Network: Modbus TCP, BACnet/IP, Ethernet TCP/IP, HTTP, HTTPS, SNMP, SMTP, SFTP
Setup configuration	Via configuration software/display	Via configuration software/display	Via PXMP configuration software
Dimensions	Refer to TD1702BTE	Refer to TD1703ATE	Refer to TD150006EN (see Page V3-T9-110)
Operating temperature range	–20° to 70°C	–20° to 70°C	–20° to 70°C
Reference literature	—	—	TD150006EN

Notes

- ^① Relays programmable to operate on any measured function.
- ^② Optional.
- ^③ An IPONI is required.
- ^④ IQ 230M only.

Legend: PG = Programmable
FS = Full scale
RV = Read value

Power Xpert 4000/6000/8000 Series Display and Meter



Contents

<i>Description</i>	<i>Page</i>
Metering Products Family	V3-T9-6
Power Xpert Meter 4000/6000/8000 Series	
Power Xpert Meter 2000 Series	V3-T9-26
IQ 250/260 Series Electronic Power Meters	V3-T9-35
IQ 130/140/150 Series Electronic Power Meters	V3-T9-41
IQ 150S/250S Self-Enclosed Electronic Meters	V3-T9-46
IQ 35M	V3-T9-51
IQ Analyzer 6400/6600 Series	V3-T9-54
IQ DP-4000 Series	V3-T9-62
Power Xpert Multi-Point Meter	V3-T9-68
PM3 Monitoring and Metering Module	V3-T9-80
Current Transformers (CTs)	V3-T9-81
Clamp-On Current Transformers	V3-T9-90
IQ Flange	V3-T9-93
Panel Mounting Adapter Kit	V3-T9-94
Enclosed Meters	V3-T9-95



Power Xpert Meter 4000/6000/8000 Series

Product Description

The Power Xpert Meter 4000/6000/8000 Series monitors the critical aspects of an electrical distribution system. This premier power quality metering instrument is simple to use, powerful, scalable and highly flexible.

The Power Xpert Meter 4000/6000/8000 offers a new level of intuitive user interface design, presenting critical electrical distribution system information in simple-to-navigate and easy-to-understand information architecture. The Power Xpert Meter 4000/6000/8000 graphic display visualizes the information from up to 16 meter modules. The embedded Web server displays complex power quality data using standard Internet browsers and allows for device configuration from the browser.

Both the local display and the embedded Web server present real time, historical and event information in a browser-style graphical format to help the user interpret key circuit information, such as:

- Current loading
- Voltage and power levels
- Power factor
- Energy usage
- I/O status
- Power quality measurements
- Harmonic plots
- Disturbance and transient waveforms
- ITIC disturbance summary screen

The Power Xpert Meter 4000/6000/8000 color touchscreen displays allow the user to easily view meter parameters and historical data.

The Web server provides the energy and demand readings required to help manage the cost of energy. It also provides critical information regarding power quality, such as harmonic distortion, flicker, crest factor, K-factor and more.

Note: Features and functionality may vary depending on the meter model and options being used. Review the Features and Benefits chart on **Page V3-T9-16** for details.

Standards and Certifications

- Safety: EN61010-1, UL/cUL 61010-1
- Accuracy: IEC/EN60687 0.2 Class, ANSI C12.20 0.2 Class
- EMC: FCC Part 15 Subpart B Class A EN55011 Class A
- Measurement Canada Approval No. AE-1898 (4000/6000 meters)
- Immunity IEC 61326
- CE Mark



Application Description**Identify Power Quality Problems to Help:**

- Identify harmonics, sags, swells and transients damaging or disrupting sensitive, mission-critical IT equipment
- Boost IT equipment's service life to the maximum
- Analyze sequence of events up to 1 millisecond time resolution
- Protect motors from damage
- Preserve the integrity of processes and batches
- Prevent blown capacitor bank fuses
- Protect transformers and conductors from overheating

Detect and Record High-Speed Transients to Help:

- Avoid equipment damage and disruption
- Identify equipment malfunction

Monitor Circuit Loading to Help:

- Avoid overloads and nuisance overload trips
- Maximize equipment utilization
- Manage emergency overloads

Manage Energy Utilization to Help:

- Reduce peak demand charges and power factor penalties
- Identify excessive energy consumption

Metered/Monitored Parameters

Note: See **Page V3-T9-16**.

- Volts: L-L, L-N, Avg. L-L, Avg. L-N, N-G
- Phase neutral and ground currents
- Power: real, reactive and apparent
- Frequency
- Power factor: apparent and displacement
- Energy
- Demand
- % THD
- Minimum and maximum values
- Harmonics
- Flicker
- Individual harmonics
- Interharmonics
- % TDD
- ITIC events plot, duration, magnitude
- Energy comparisons
- Demand comparisons
- Event calendar
- Event timeline and sequence
- Number of 9s of availability
- Phasors
- Sequence components
- Crest factor
- K-factor
- PQ Index

Accuracy

- Currents: 0.05% RV + 0.025%FS
- Voltage: 0.1% RV + 0.025% FS
- Energy and demand power: 0.2% in accordance with ANSI C12.20
- Frequency: ± 0.01 Hertz
- Power factor:
 - 0.10% at Unity PF
 - 0.30% at 0.5 PF

Communications

Multiple communications ports including:

Standard

- RS-485 remote display port
- RS-485 Modbus RTU slave port
- RJ-45 10/100Base-T local configuration port (local Web server connection)
- HTTP (local), FTP, COMTRADE

Optional

- Communications Expansion Card (CEC)
 - Selectable 100FX or 10/100Base-T Ethernet network port
 - RS-485 Modbus RTU selectable master/slave port
 - RS-232 Modbus RTU slave port

Communication Protocols Supported

- Modbus RTU
- Modbus TCP
- Ethernet TCP/IP
- HTML
- NTP (Network Time Protocol)
- FTP (File Transfer Protocol)
- SMTP (Simple Mail Transfer Protocol)
- SNMP (Simple Network Management Protocol)
- COMTRADE (IEEE C37.111-1999)
- DNP 3.0 over Ethernet (Distributed Network Protocol)

Display/Meter Mounting Options

- The 6-inch color touchscreen display can be mounted back-to-back with one Power Xpert meter module on opposite sides of a panel

Meter Base Unit Characteristics

- NEMA rating: NEMA 1, IP30

Display Unit Characteristics

- NEMA rating: NEMA 12, IP42 front of panel rating

Power Xpert Meter 4000/6000/8000 Displays (Option)

The Power Xpert Meter 4000/6000/8000 has two display options: a 6-inch color touchscreen display (PXM468K-DISP-6) and a 12-inch advanced color touchscreen display (PXM468K-DISP-12).

The 6-inch color touchscreen display allows access to real-time metered values, min/max values, power quality, I/O (input/output), events and graphical trend charts.

The advanced 12-inch touchscreen display provides access to all measured and stored parameters in the meter. It supports graphical real-time information, trend charts of key circuit measurements, waveforms, harmonics and calendar displays.

All meter setup and programming can be performed through the display.

Inputs and Outputs

Power Xpert Meter 4000/6000/8000 is available with an optional digital I/O card, which includes:

- Eight digital inputs—self sourced 24 Vdc
- Three relay outputs—5A max. continuous, 240 Vac max., 30 Vdc max.
- Two solid-state outputs—80 mA max. continuous, 30 Vdc max.

Each of the 8 inputs are interrupt driven, allowing for 1 ms accuracy of digital events time stamps (1 ms accuracy requires local NTP TimeServer). Inputs can also be configured for demand synch and pulse counting. Inputs selected for pulse counting can be scaled. Interval by interval pulse recordings are maintained in profile memory and can be displayed graphically. Outputs can be used for KYZ, or alarm annunciation.

Ratings

- Application to 500 kV, no PTs to 600V
- CT ratios selectable from standard 120/600 Vac line
- CT inputs accept 5A secondary
- Power supply:
 - Standard 120/240 Vac or 110/250 Vdc

Storage Capacity

Power Xpert Meter 4000/6000/8000 Estimated Memory and Storage Capacity with 2/4/8 GB Memory Capacity

Model	Memory	Event	File Size (KB)	Occurrence Per Month ^①		Memory Usage (MB)		Months of Capacity ^②	
				Typical	Severe	Typical	Severe	Typical	Severe
PXM 4000	2 GB	Subcycle Disturbance	1260	10	60	12.3	73.8	166	28
PXM 6000	4 GB	ITIC Event	1260	5	20	6.2	24.6	666	166
		Subcycle Disturbance	1260	10	60	12.3	73.8	333	55
		ITIC + Subcycle Disturbance	Total--->	15	80	18.5	98.4	222	42
PXM 8000	8 GB	ITIC Event	1260	5	20	6.2	24.6	1332	333
		Subcycle Disturbance	1260	10	60	12.3	73.8	666	111
		Transients	2048	3	30	6.0	60.0	1365	137
		ITIC + Subcycle Disturbance + Transients	Total--->	18	110	24.5	158.4	335	52

Notes

- ① The typical and server power quality event occurrences are estimates and may vary depending on the electrical environment.
- ② Memory is not allocated by event category; memory is used first come, first served.

Features and Benefits

Power Xpert Meter 4000

- Harmonics, including individual harmonics
- Disturbance capture
- Low frequency transient detection and capture
- Standard power quality index

Power Xpert Meter 6000

- Interharmonics
- Flicker calculations
- ITIC performance curve
- Event calendar view
- Events timeline view
- Sequence of events waveform plot
- Enhanced power quality index

Power Xpert Meter 8000

- Impulsive transient capture at 6 MHz
- 100,000 samples per cycle
- Premium power quality index

Power Xpert Meter 4000/6000/8000

Feature	Power Xpert Meter			Benefit
	4000	6000	8000	
General				
Embedded Web server	■	■	■	Use a standard Web browser to monitor and manage the meter over the network, Internet
TOU metering support	■	■	■	Time of usage can be set up to support 4 different schedules
Firmware flash update support	■	■	■	Enables you to flash the meter with the latest firmware updates
Self-learning capability (characterizes "normal" per circuit)	■	■	■	The meter can automatically adjust to the environment and alarm only when "real" events occur
Power, Energy and Demand				
Voltage, current: per phase minimum, maximum, average, trend graph analysis, export, print	■	■	■	Review voltage and current trends, export, print and analyze parameters right on the meter or external software
Energy and demand plot comparisons month-to-month, week-to-week	■	■	■	Plot two months or two weeks for vivid energy or demand comparison
Power: power factor, apparent, real, reactive, frequency	■	■	■	Review power usage and power factor and avoid potential PF penalties
Energy, demand: forward, reverse, net, sum, tou, profile, previous month comparison, graph analysis, export, print	■	■	■	Keep track of your energy usage, compare time of usage and usage against previous month, identify peaks to conserve energy usage
Power Quality Analysis				
Statistical analysis (min., max., average)	■	■	■	Review statistical trends, identify past and future problem areas
Sag and swell monitoring, management and recording	■	■	■	Capture electrical sags and swells and analyze the waveforms
Symmetrical Components: Zero, Negative, Positive	■	■	■	Analyze possibly unbalanced three-phase power systems
Low frequency transient detection and capture	■	■	■	Capture lower frequency transient waveforms for retrospective analysis or e-mailing
Sampling rate, maximum samples/cycle	4096 ①	4096 ①	100,000	Extremely high sampling rate will effectively capture impulsive transients
"Number of Nines" uptime data (e.g., 6 nines = 99.9999%)	■	■	■	Review uptime availability per cent
K-factor	■	■	■	Review the ratio of eddy current losses, e.g., when driving nonlinear and linear loads
Crest factor	■	■	■	Review the peak-to-average ratio of the waveform
Security				
Secure 5 level user access privileges	■	■	■	Define appropriate security access level per user
Communications and I/O				
Modbus TCP	■	■	■	Easy integration with standard protocol to power management and other software
Modbus RTU	■	■	■	Integrate meters to existing Modbus networks, daisy chain several (1–16) meters together
HTML	■	■	■	Communicate to the meter over the Internet via standard Web browser
SNMP (simple network management protocol)	■	■	■	Communicate with the meter via Simple Network Protocol; hook to existing NMS system
SMTP (simple mail transfer protocol)	■	■	■	Send e-mail messages via standard Simple Mail Transfer Protocol
FTP (file transfer protocol)	■	■	■	Access, copy, paste, cut waveform capture files on the meter with an FTP Client
NTP (network time protocol)	■	■	■	Network Time Protocol support enables the meter to synchronize time over the network up to the 1 millisecond resolution
COMTRADE, open IEEE Standard file format for Waveform capture export	■	■	■	Import waveform captures in standard IEEE (C37.111-1999) COMTRADE file format to third-party software
DNP 3.0 over Ethernet (Distributed Network Protocol)	■	■	■	Communicate with the meter via DNP 3.0 over Ethernet; hook to existing utility systems

Notes

These specifications are subject to change without notice and represent the maximum capabilities of the product with all options installed. This is not a complete feature list. Features and functionality may vary depending on selected options, firmware version and product model. Please refer to the technical data sheet and User Manual for detailed specifications.

① Delta-Sigma A/D oversampling rate.

Power Xpert Meter 4000/6000/8000, continued

Feature	Power Xpert Meter			Benefit
	4000	6000	8000	
Communications and I/O, continued				
Trend measurements CSV file export	■	■	■	Easily export trend measurements to third-party applications, e.g., Microsoft Excel in standard CSV file format
I/O (8 digital inputs, 3 relay outputs, 2 solid-state KYZ outputs)	■	■	■	The Power Xpert I/O Card is extremely flexible and can be used in a large variety of different applications. Digital inputs and relay outputs can be programmed to interact during various conditions defined by the user. Various third-party devices, such as alarm, pulse meters, trip units, sensors can be easily integrated to the Power Xpert Meter. Triggers and events can be tied to the meters standard functions such as e-mail, logs and trends
Time Synchronization				
NTP time synchronization up to 1 millisecond accuracy	■	■	■	Network Time Protocol support enables the meter to synchronize time over the network up to the 1 millisecond resolution
GPS time synchronization up to 1 millisecond accuracy	■ ^①	■ ^①	■ ^①	The GPS option allows the meter to synchronize time over the GPS satellite positioning system up to the 1 millisecond resolution
Logs				
Trend logging	■	■	■	Log trend information for easy statistical analysis
Load profile	■	■	■	Review the load profile graph to get a better understanding of your electrical load versus time
Event logging	■	■	■	Log events for retrospective event analysis
Memory and Storage				
Standard memory, GB	2	4	8	Store large amounts of waveform captures and events for historical analysis
Harmonics				
Harmonic levels	127	127	127	Provides extremely fast, high resolution D/A conversion
Total harmonic distortion (THD)	■	■	■	Review the total harmonic distortion level directly on the meter
Delta-Sigma D/A conversion technology	■	■	■	Provides extremely fast, high resolution D/A conversion
Harmonics over-sampling (4096 samples per cycle)	■	■	■	Over-sampling enables the usage of Anti-Aliasing technology, increasing accuracy
Anti-alias filtering	■	■	■	Technology to remove out-of-band signal components resulting in more accurate data
Individual harmonics	■	■	■	Review individual harmonic levels directly on the meter
Total demand distortion (TDD)	■	■	■	Identify harmful harmonics in e.g. lightly loaded variable-speed drive environments where THD may be high but not relative
Interharmonics		■	■	Interharmonics allow you to see what is going on between the integer multiples of the fundamental. Zoom in on the harmonics trend graph and review frequency content every 5 Hz instead of every 60 Hz
Highlights				
Sub-cycle disturbance capturing	■	■	■	Capture fast voltage changes/low frequency transient (e.g. capacitor switching transient)
dV/dt triggers for sub-cycle oscillatory transients	■	■	■	Detect and record a large magnitude oscillation transient resulting in equipment damage
Absolute threshold and dV/dt triggering	■	■	■	Detect and record if a surge suppressor is necessary
Power quality index—standard (includes dv/dt count, %TDDi and %THDv)	■	■	■	Complex power quality data put into simple graphic format
Power quality index—enhanced (includes Standard Index plus Sag level, Swell level and Flicker)		■	■	Complex power quality data put into simple graphic format (includes ITIC events and flicker calculations)
Flicker calculations		■	■	Detect and quantify low frequency rms voltage variations causing incandescent lighting flicker
Automatic trigger setting		■	■	Trigger thresholds are automatically set according to ITIC (CBEMA) standard, no need to figure this out by yourself
Automatic event severity analysis		■	■	Automatically analyze the severity of the event with the ITIC (CBEMA) performance curve plot, see where the event actually hit

Notes

These specifications are subject to change without notice and represent the maximum capabilities of the product with all options installed. This is not a complete feature list. Features and functionality may vary depending on selected options, firmware version and product model. Please refer to the technical data sheet and User Manual for detailed specifications.

① When used with third-party device and I/O option.

Power Xpert Meter 4000/6000/8000, continued

Feature	Power Xpert Meter			Benefit
	4000	6000	8000	
Highlights, continued				
Event severity counters		■	■	An ITIC (CBEMA) event counter keeps track of the number of all sags, swells and transients
ITIC (Information Technology Industry Council), previously CBEMA performance curve		■	■	ITIC (Information Technology Industry Council), previously CBEMA performance curve for easy power problem evaluation
Custom ITIC (CBEMA) plot with individual event magnitude and duration		■	■	Review custom ITIC (CBEMA) plots of individual events showing you the actual magnitude, duration and hit are in a simple graphical representation
Event calendar view		■	■	The Events Timeline calendar view provides instant insight to the frequency of power events and helps detect reoccurring problems
Events timeline view		■	■	View and understand the sequence of events that have occurred during a period of time
Sequence of events and events plot on waveform		■	■	Plot color-coded events on a captured waveform to gain insight into the sequence of events cycle per cycle
Power quality index—premium (at-a-glance “thermometer” view of power quality)			■	Complex power quality data put into simple graphic format (includes ITIC events and flicker calculations)
High-Speed Transient Capture and Detection				
6 MHz capture of impulsive transients			■	Capture impulsive transients by taking 6 samples every millionth of a second
Transient Capture Duration: ~20 ms/6 MHz ~120 ms/1 MHz			■	Record and analyze transients during a longer timeframe
Waveform recorded at 100,000 samples per cycle			■	High-speed ensures impulsive transients are correctly captured (fast rise time)
Three-phase voltage and neutral-to-ground fast transient capture			■	Capture impulsive transients on all 4 channels

Discrete Contact Inputs

The optional PXMIO-B expansion card offers 8 digital inputs that are useful for a variety of applications such as:

- Status indication with time stamping of transitions (1 ms precision).
- Pulse counting of KYZ or other utility pulses such as air, water or gas.
- High-speed triggering of waveforms based on events such as breaker trips or static transfers
- Demand interval timing taken from a master utility meter end of interval pulse

Status inputs are self sourced providing a nominal 24 Vdc (20–30 Vdc) across the circuit.

Names can be configured for each input for ease of use.

Relay Outputs

The optional PXMIO-B card includes three 5A form C relay outputs rated for 240 Vac or 30 Vdc. These outputs can be used for applications such as:

- Alarm annunciation
- KYZ pulse output

Alarm outputs can be driven from triggers based on metering values. Output modes include:

- Normal—relay energized during alarm condition
- Latched—relay energized by event trigger, de-energized by acknowledgement
- Timed—relay energized by event trigger, maintained for a programmed interval.

Communications Expansion Card (CEC)

The optional PXMCE-B Card offers two Ethernet connection options, 10/100Base-T and a fiber-optic port that can be used for the following applications:

- Monitoring, managing and configuring the meter remotely using a standard Web browser interface like Microsoft Internet Explorer
- Alarm notifications via e-mail, SMTP
- Enabling access to the meter’s FTP server (energy, trend and waveform logs)
- Providing Modbus TCP/IP or RTU communications to BMS systems
- Providing DNP 3.0 over Ethernet to utility systems
- Providing SNMP communications to NMS systems
- Synchronizing with an NTP server for 1ms timestamping resolution
- Asset management via SNMP to Network Management Systems
- Updating firmware on the meter

Notes

These specifications are subject to change without notice and represent the maximum capabilities of the product with all options installed. This is not a complete feature list. Features and functionality may vary depending on selected options, firmware version and product model. Please refer to the technical data sheet and User Manual for detailed specifications.

Power Xpert Meter 4000/6000/8000 Module Layout

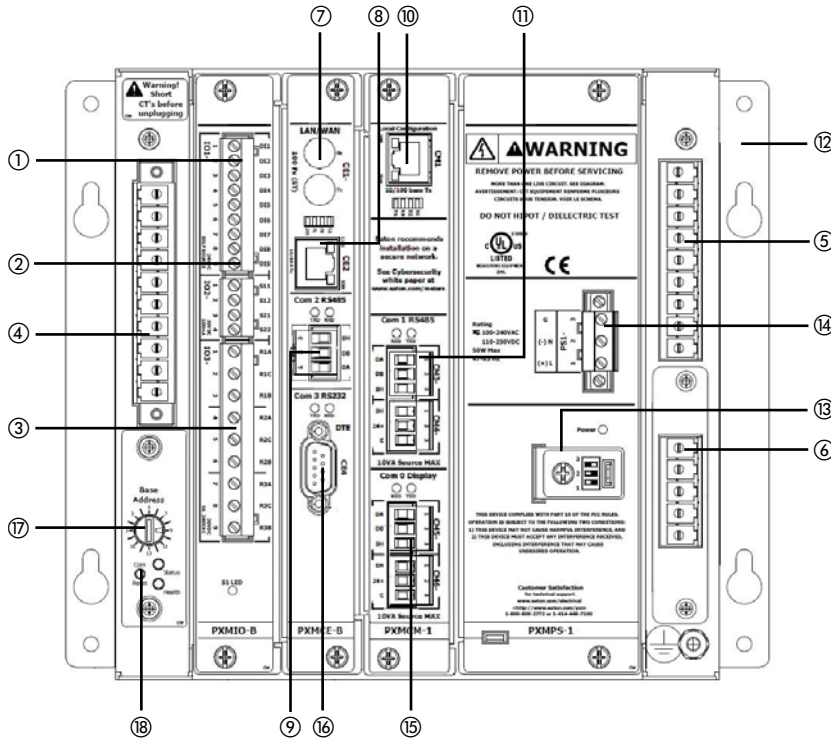

I/O Card

- ① Digital inputs 1–8 (option)
- ② Solid-state outputs 1–2 (option)
- ③ Relay outputs 1–3 (option)

CT and Voltage Connections

- ④ CT input connections
- ⑤ Standard three-phase voltage phase inputs
- ⑥ Aux. channel voltage inputs (option)

Communication Expansion Card (LAN/WAN Ethernet Networking)

- ⑦ 100FX ST-type Ethernet (multi-mode) (option)
- ⑧ 10/100Base-T Ethernet (option)
- ⑨ RS-485 (two-wire w/shield)—24V accessory power (com 2)

Standard Features

- ⑩ Local RJ-45 config. port (non-networkable Ethernet)
- ⑪ RS-485 (two-wire w/shield) Modbus RTU (com 1)
- ⑫ Meter mounting brackets
- ⑬ Sealable mode switch cover
- ⑭ Control power (100–240 Vac and 110–250 Vdc) ($\pm 20\%$)
- ⑮ Display RS-485 Network port (up to 15 meters)—24V accessory power (com 0)
- ⑯ RS-232 (Tx Rx) Modbus RTU (com (3) (option)
- ⑰ Meter base address
- ⑱ Com Reset Button

Catalog Number Selection

To order a Power Xpert Meter 4000/6000/8000, the catalog number should be determined using the chart shown below. The chart illustrates how to include the desired factory options as part of a catalog number. Option cards that are selected at time of order entry will be installed at the factory. Option cards are also field installable for field upgrades.

If a display is required, it should be ordered separately. Power Xpert Meter modules include panel mounting brackets. The color touchscreen displays are designed to mount separately. If back-to-back meter to display panel mounting is desired, a mounting bracket kit is available (**PX-PMBD**) for the 6-inch color touchscreen display. The 12-inch advanced color touchscreen display cannot be back-to-back mounted.

Example 1: PXM8251A1BB
(PXM 8000 Meter, w/ VAUX, Std. Pwr, Com. Exp. & I/O Cards)

Example 2: PXM6251A1BA
(PXM 6000 Meter, w/ VAUX, Std. Pwr, Com. Exp. Card)

Power Xpert Meter 4000/6000/8000

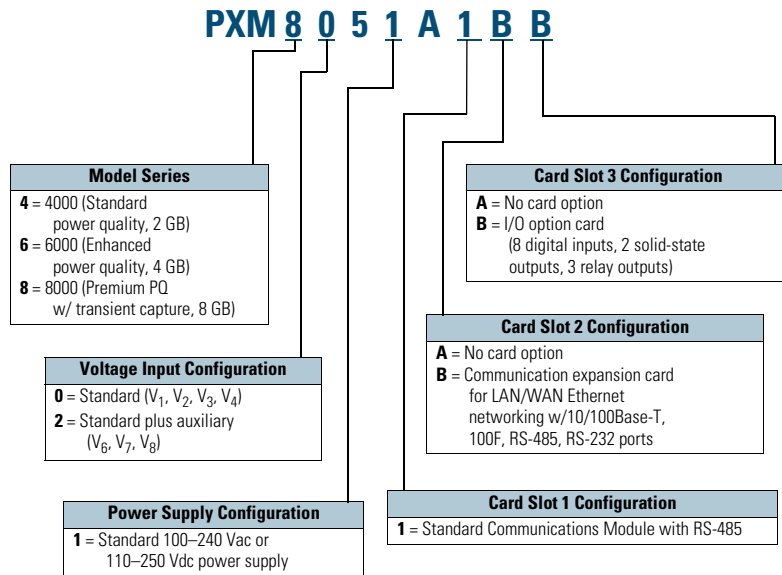

Example 1: **PXM8251A5BB** (PXM 8000 meter, w/ VAUX, std. pwr., com. exp. and I/O cards)
 Example 2: **PXM6251A6BA** (PXM 6000 meter, w/ VAUX, std. pwr., com. exp. card)

Accessories

Power Xpert Meter 4000/6000/8000

Description	Catalog Number
6-inch color touchscreen display	PXM468K-DISP-6
12-inch advanced color touchscreen display	PXM468K-DISP-12
Communication expansion card for LAN/WAN Ethernet networking: 100FX fiber-optic, 10/100T, RS-485, RS-232	PXMCE-B ①
Digital I/O card: eight digital input, two solid-state output, three relay output	PXMIO-B ①
Panel mounting bracket assembly for back-to-back meter to 6-inch color touchscreen display mounting	PX-PMBD
Panel mounting bracket assembly for retrofitting a 6-inch color touchscreen display to IQ Analyzer cutout	PX-PMBE
Panel mounting bracket assembly for retrofitting a 6-inch color touchscreen display to PXD-MMG cutout	PX-PMBF

Notes

① These items can be ordered separately or preinstalled in the meter by selecting option B in the model number.

Communication cable (standard Modbus RTU) is not included in the package for meter module connection.

Technical Data and Specifications

Environmental Conditions

- Operating temperature:
 - Meter: -20 to +70°C
 - Display: -20 to +60°C operating
- Storage temperature: -40 to +85°C
- Operating humidity: 5% to 95% condensing
- Device weight: 7.1 lbs—meter 2.1 lbs—display
- Meter and back of display are pollution degree 2
- Elevation to 6562 ft (2000m)

Current Inputs (Each Channel)

- Conversion: 4096 samples per cycle delta-sigma converter digitally filtered down to 512 samples per cycle
- CT Input: 4096 rms samples per cycle delta-sigma converter digitally filtered down to 512 samples per cycle for anti-aliasing
- Burden: less than 10 milliohms
- Overload withstand: 500A for 1 second, non-repeating
- Range: 0.005–20A continuous
- Accuracy: 0.05% or reading plus 0.01% of full scale (from 50 milliamps to 20A)

Voltage Inputs (Each Channel)

- Conversion: 4096 rms samples per cycle delta-sigma converter digitally filtered down to 512 samples per cycle for anti-aliasing
- PT input: 120V–500,000V primary
- Input range: 600V L-L, 347 L-N direct connect
- Nominal full scale: 1000V rms
- Input impedance: 2 megohms

Frequency Range

- 47–63 Hz

Harmonic Response (Voltage, Current)

- 127th harmonic

Accuracy

- ANSI C12.20 0.2 Class
- IEC 687 0.2 Class

Discrete Inputs

- Self sourced: 24 Vdc

Relay Output Contacts

- 5A maximum, 240 Vac maximum, 30 Vdc maximum
- Lifetime: 1,000,000 no load operations
- 100,000 under rated voltage and load

Solid-State Outputs

- Maximum load: 100 milliamps
- Maximum voltage: 30V (externally sourced)

Control Power Input

- Input range AC: 100–240 Vac (±20%)
- Frequency range: 47–63 Hz
- Input range DC: 110–250 Vdc ±20%
- Burden 50 VA
- Ride-through: 1–5s

Wiring Diagrams

Three-Phase, Three-Wire Delta (Up to 600 Volts)

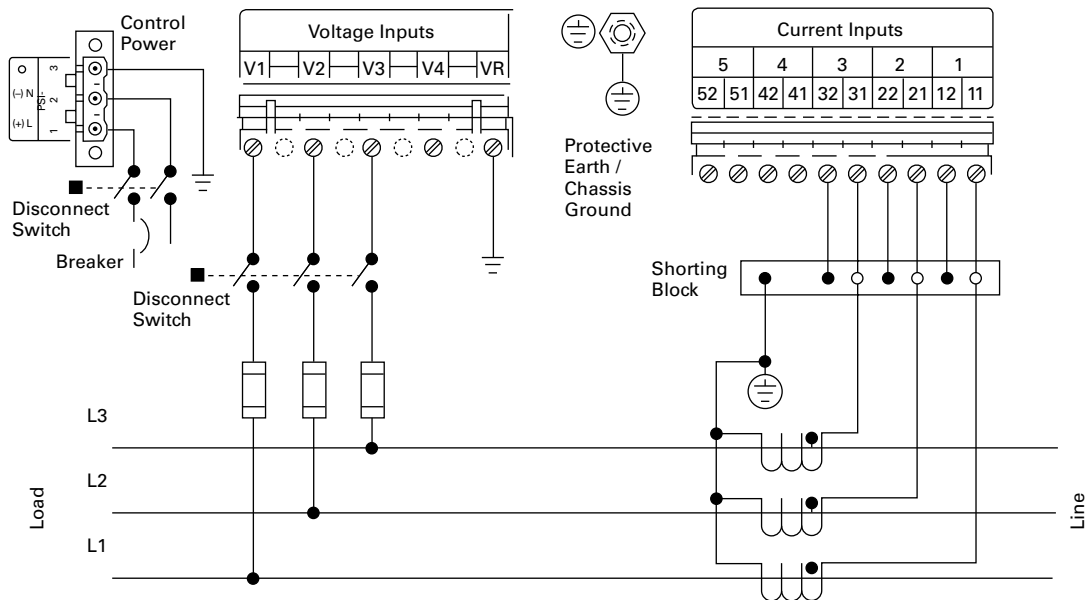

Three-Phase, Three-Wire Delta (Above 600 Volts)

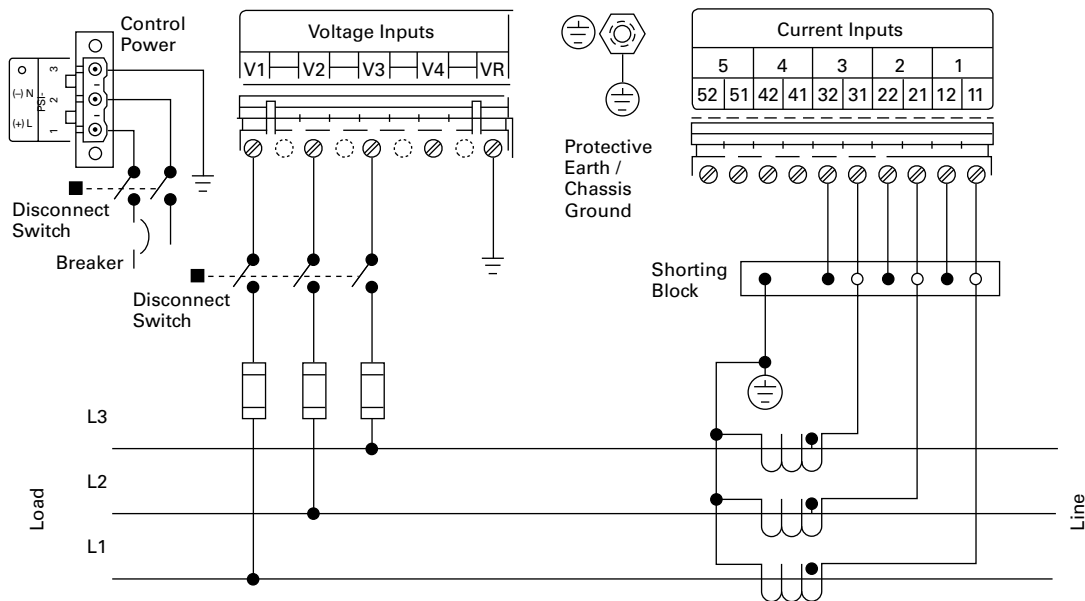

Note

Based upon the voltage rating, you may need a control power transformer for the control power.

Power Xpert Meters Configuration and Wiring Examples

Modbus RTU (RS-485) – Non-Web Enabled

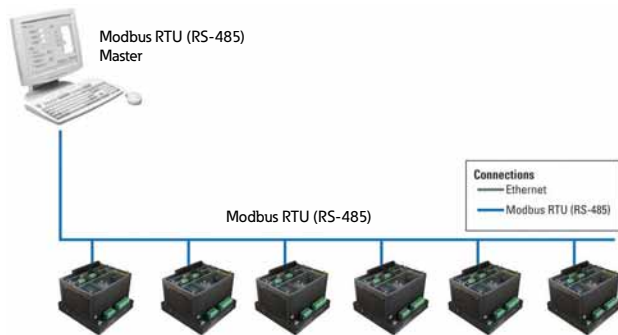

Web Enabled – Browser and Modbus TCP

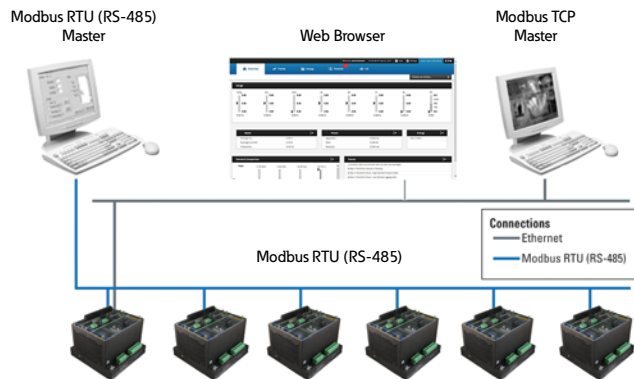

Accessories – I/O Card (Option)

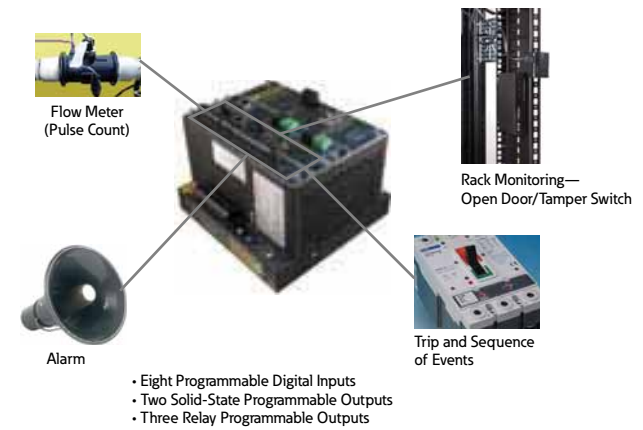

IT Configuration Examples – Accessories – I/O Card (Option)

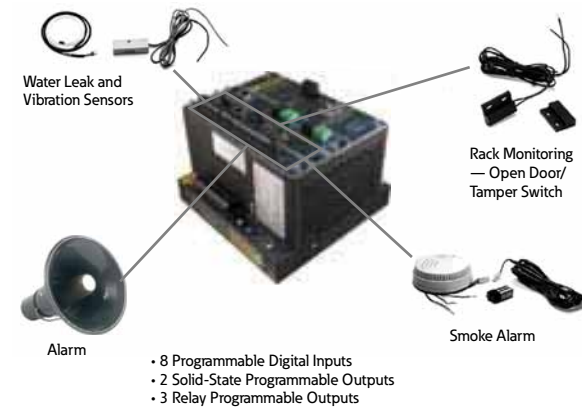

9.2

Metering Devices, Protective Relays, Software and Connectivity

Metering Devices

Dimensions

Approximate Dimensions in Inches (mm)

Power Xpert Meter 4000/6000/8000 12-Inch Advanced Color Touchscreen Display (PXM468K-DISP-12) – Sold Separately

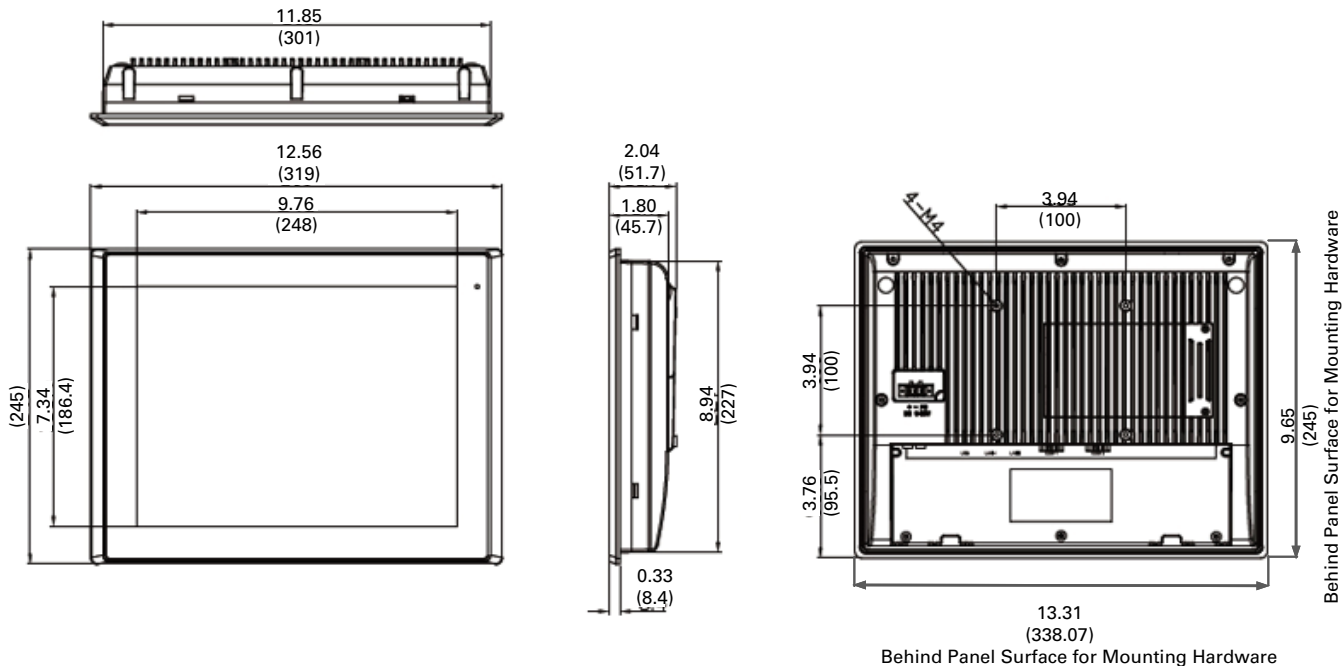

Power Xpert Meter 4000/6000/8000 6-Inch Color Touchscreen Display (PXM468K-DISP-6) – Sold Separately

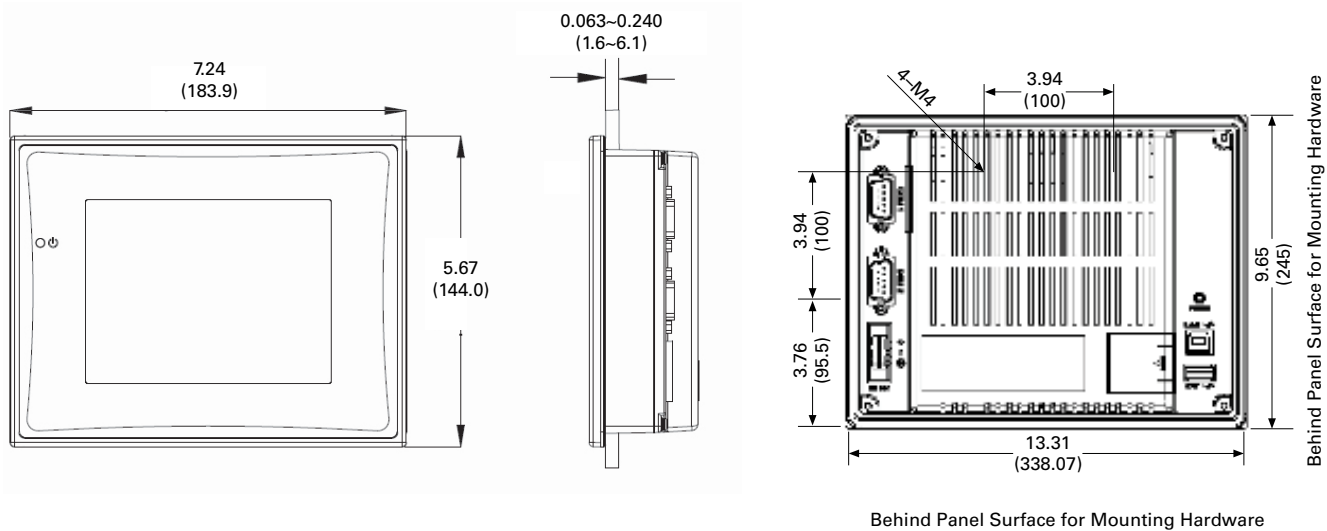

Approximate Dimensions in Inches (mm)

Power Xpert Meter 4000/6000/8000 Module

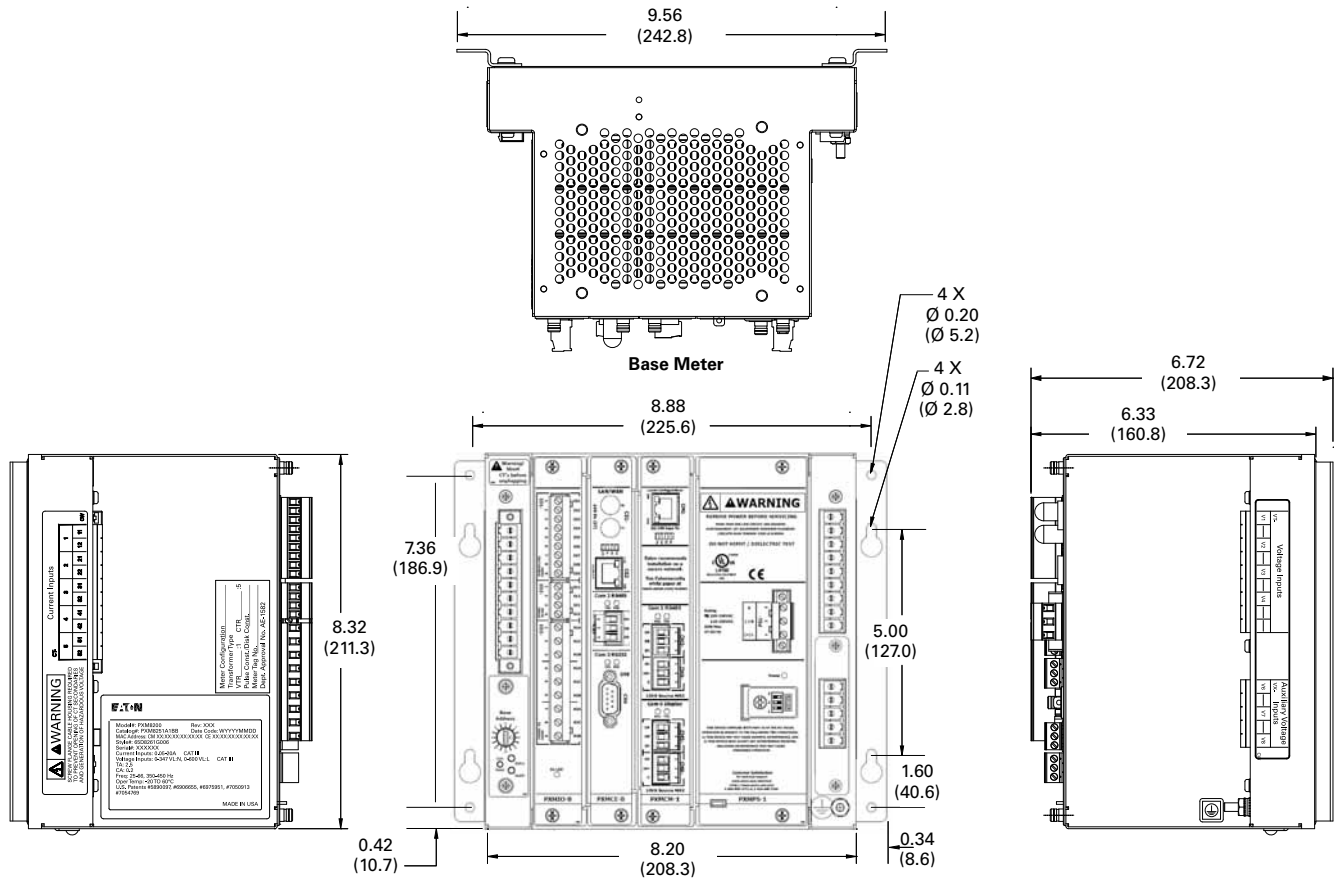

Meter Base Unit

Width	Height	Depth
9.56 (242.8)	8.88 (225.6)	6.72 (170.8) ①

Display Unit

Height	Width	Depth
Projection In Front of Panel Surface		
9.02 (229.0)	7.80 (198.1)	1.04 (26.3)
Behind Panel Surface		
9.02 (229.0)	7.80 (198.1)	1.45 (36.8)

Note

① Including optional wall mounting brackets.

Power Xpert Meter 2000 Series



Power Xpert Meter 2000 Series

Product Description

The Power Xpert Meter 2000 Series power quality instrument monitors the most critical aspects of an electrical distribution system. This premier power quality metering instrument uses the latest in advanced technology to make it simple to use, powerful, scalable and highly flexible. The Power Xpert Meter 2000 offers the same level of intuitive user interface design as the Power Xpert Meter 4000/6000/8000, presenting critical electrical distribution system information in a simple to navigate and easy-to-understand information architecture.

The embedded Web server displays comprehensive power quality data using standard Internet browsers and allows for device configuration from the browser. The embedded Web server presents real time, historical and event information in a browser-style graphical format to help the user interpret information such as current loading, voltage and power levels, power factor, energy usage, I/O status, power quality measurements, as well as harmonic plots. The embedded Web server also allows for waveform capture and for visualizing steady-state harmonic content that is critical for power quality analysis.

The Web server provides the energy and demand readings required to help manage the cost of energy.

Contents

<i>Description</i>	<i>Page</i>
Metering Products Family	V3-T9-6
Power Xpert Meter 4000/6000/8000 Series	V3-T9-13
Power Xpert Meter 2000 Series	
IQ 250/260 Series Electronic Power Meters	V3-T9-35
IQ 130/140/150 Series Electronic Power Meters	V3-T9-41
IQ 150S/250S Self-Enclosed Electronic Meters	V3-T9-46
IQ 35M	V3-T9-51
IQ Analyzer 6400/6600 Series	V3-T9-54
IQ DP-4000 Series	V3-T9-62
Power Xpert Multi-Point Meter	V3-T9-68
PM3 Monitoring and Metering Module	V3-T9-80
Current Transformers (CTs)	V3-T9-81
Clamp-On Current Transformers	V3-T9-90
IQ Flange	V3-T9-93
Panel Mounting Adapter Kit	V3-T9-94
Enclosed Meters	V3-T9-95



Application Description

Identify Power Quality Problems to Help:

- Protect motors from damage
- Preserve the integrity of processes and batches
- Prevent blown capacitor bank fuses
- Protect transformers and conductors from overheating

Monitor Circuit Loading to Help:

- Avoid overloads and nuisance overload trips
- Maximize equipment utilization
- Manage emergency overloads

Manage Energy Utilization to Help:

- Reduce peak demand charges and power factor penalties
- Identify excessive energy consumption

Features, Benefits and Functions

Metered/Monitored Parameters

Note: See Table on Page V3-T9-28.

- Volts: L-L, L-N, Avg. L-L, Avg. L-N
- Phase and neutral currents
- Power: real, reactive and apparent
- Frequency
- Power factor: apparent
- Energy: real, forward, reverse, sum
- Demand: peak with date and time
- % THD
- Minimum and maximum values
- Harmonics
- Individual harmonics
- Demand comparisons
- Phasors

Accuracy

Note: Under typical operating conditions.

- Currents: 0.1% RV
- Voltage: 0.1% RV
- Energy and demand power: 0.2% in accordance with ANSI C12.20
- Frequency: ±0.03 Hz
- Power factor: 0.2% RV

Communications

Multiple communications ports including:

Standard

- RS-485 Modbus RTU slave port
- 10/100Base-T Ethernet network port

Communication Protocols Supported

- Modbus RTU
- Modbus TCP
- BACnet/IP
- Ethernet TCP/IP
- HTTP, HTTPS
- NTP (Network Time Protocol)
- SMTP (Simple Mail Transfer Protocol)
- SNMP (Simple Network Management Protocol) v1, v3
- DNP 3.0

Physical Characteristics

Format

- Power Xpert Meter 2000 with integral display
- Power Xpert Meter 2000 transducer only (no display) meter module
- NEMA rating: NEMA 12, IP42 front of panel rating

Inputs and Outputs

Power Xpert Meter 2000 is available with a standard KYZ output and optional digital I/O cards that includes:

- Two relay outputs/two status inputs
- Four KYZ pulses/four status inputs
- Four analog outputs 0–1 mA
- Four analog outputs 4–20 mA

Inputs can also be configured for demand synch and pulse counting. Inputs selected for pulse counting can be scaled. Accumulated pulse recordings are maintained in profile memory. Outputs can be used for alarm annunciation.

Ratings

- Application to any PT ratio, no PTs required to 600 Vac
- CT ratios to any CT ratio
- CT inputs available as 5 or 1A secondary
- Separate source control power input:
 - 90–265 Vac or 100–370 Vdc
 - Low voltage 18–60 Vdc

Displayed Information

- Monitored information is available locally through the display, the Web browser or system power management software
- True rms values through 40th harmonic
- ANSI C12.20 Class.2% revenue metering specification

Relay Outputs

The optional I/O card includes two 5A Form C relay outputs rated for 240 Vac or 30 Vdc or four Form A solid-state outputs. These outputs can be used for applications such as:

- Alarm annunciation
- KYZ pulse output

Alarm outputs can be driven from triggers based on metering values.

Analog Outputs

The optional IO card includes either four 4–20 mA outputs or 0–1 mA outputs. These outputs can be used for applications such as:

- Input to BMS or PLC systems for tracking a measured meter parameter

Standard Communications Card

The standard communications card provides one Ethernet connection and 10/100Base-T port (copper only) that can be used for the following applications:

- Monitoring, managing and configuring the meter remotely using a standard Web browser interface
- Alarm notifications via email, SMTP
- Providing Modbus TCP/IP, RTU and BACnet/IP communications to BMS systems
- Providing SNMP communications to NMS systems
- Synchronizing with an NTP server
- Asset management
- Updating firmware on the meter

PXM 2000 Rear View

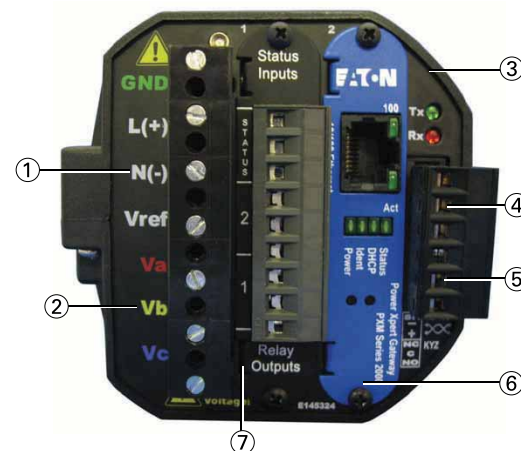

- ① Power supply inputs
- ② System voltage inputs
- ③ NEMA 12 gasket
- ④ RS-485
- ⑤ KYZ out
- ⑥ Meter gateway card
- ⑦ I/O slot

Power Xpert Meter 2250

- Measures basic meter parameters
- 256 MB for data logging
- Ethernet
- On-board gateway card limits/alarms

Power Xpert Meter 2260

Features of PXM 2250 plus:

- Harmonics
- On-board meter hardware limits to activate optional relay outputs
- Visual indication of limits exceeded at meter face
- 512 MB for data logging

Power Xpert Meter 2270

Features of PXM 2260 plus:

- Harmonics, including individual
- Waveform view to visualize steady-state harmonic content
- 768 MB for data logging

The Power Xpert Meter 2280

Features of PXM 2270 plus:

- Records waveforms at up to 64 samples per cycles
- Configures the total, pre- and post-event cycles

Power Xpert Meter 2290

Features of PXM 2280 plus:

- Records waveforms at up to 512 samples per cycles

Power Xpert Meters 2250/2260/2270/2280/2290

Feature	Power Xpert Meter					Benefit
	2250	2260	2270	2280	2290	
General						
Embedded Web server	■	■	■	■	■	Use a standard Web browser to monitor and manage the meter over the network
Firmware flash upgrade support	■	■	■	■	■	Enables you to flash the meter with the latest firmware upgrades
Power, Energy and Demand						
Voltage, current: per phase minimum, maximum, average, trend graph analysis, export, print	■	■	■	■	■	Review voltage and current trends, export, print and analyze parameters right on the meter or external software
Demand: forward, reverse, net sum, profile, export, print, plot comparisons month-to-month, week-to-week	■	■	■	■	■	Plot two months or two weeks for vivid demand comparison, receive e-mails with trend logs
Power, apparent, real, reactive, power factor	■	■	■	■	■	Review power usage and power factor and avoid potential PF penalties
Energy: forward, reverse, net, sum	■	■	■	■	■	Keep track of your energy usage, identify peaks to conserve energy usage, receive e-mails with trend logs
Power Quality Analysis						
Statistical analysis (min., max., average)	■	■	■	■	■	Review statistical trends, identify past and future problem areas
Sampling rate, maximum samples/cycle	400	400	400	400	400	High sampling rate resulting in high accuracy
Security						
Secure two level user access privileges	■	■	■	■	■	Define appropriate security access level per user
Communications						
Modbus TCP	■	■	■	■	■	Easy integration with standard protocol to power management and other software
Modbus RTU	■	■	■	■	■	Integrate meters to existing Modbus networks, daisy chain several (1–32) meters together
BACnet/IP	■	■	■	■	■	Easily integrate into existing building management systems without the need for external protocol adapters
HTTP, HTTPS	■	■	■	■	■	Communicate to the meter over the Internet via standard Web browser
SNMP (Simple Network Management Protocol)	■	■	■	■	■	Communicate with the meter via Simple Network Protocol; hook to existing NMS system
SMTP (Simple Mail Transfer Protocol)	■	■	■	■	■	Send e-mail messages via standard Simple Mail Transfer Protocol
NTP (Network Time Protocol)	■	■	■	■	■	Network Time Protocol support enables the meter to synchronize time over the network
DNP 3.0	■	■	■	■	■	Easy integration with DNP networks (serial)
Trend measurements CSV file export	■	■	■	■	■	Easily export trend measurements to third-party applications, in standard CSV file format

Note

These specifications are subject to change without notice and represent the maximum capabilities of the product with all options installed. This is not a complete feature list. Features and functionality may vary depending on selected options, firmware version and product model. Please refer to the technical data sheet and User Manual for detailed specifications.

Power Xpert Meters 2250/2260/2270, continued

Feature	Power Xpert Meter					Benefit
	2250	2260	2270	2280	2290	
Logs						
Trend logging	■	■	■	■	■	Log trend information for easy statistical analysis
Load profile	■	■	■	■	■	Review the load profile graph to get a better understanding of your electrical load versus time
Event logging	■	■	■	■	■	Log events for retrospective event analysis
Memory and Storage						
Memory, MB	256	512	768	768	768	Store trend data and events for historical analysis
Harmonics						
Harmonic levels		40th	40th	40th	40th	Allows you to identify potential harmful harmonics
Total harmonic distortion (THD)	■	■	■	■	■	Review the total harmonic distortion level directly on the meter
Individual harmonics			■	■	■	Provides simple metric for power quality viewable from the embedded Web server
Waveform						
Waveform display			■	■	■	A single-cycle waveform view on a PC, through embedded Web server, to visualize steady-state harmonic content to identify power quality issues
Waveform recording				64	512	Ability to record waveforms up to specified samples/cycle
I/O						
I/O (two relay outputs/two status inputs, four KYZ pulses/four status inputs, four analog outputs 0–1 mA, four analog outputs 4–20 mA)	Opt	Opt	Opt	Opt	Opt	The Power Xpert meter 2000 I/O Cards are extremely flexible and can be used in a large variety of different applications. Digital inputs and relay outputs can be programmed to interact during various conditions defined by the user. Various third-party devices, such as alarms, pulse meters, trip units and sensors, can be easily integrated to the Power Xpert Meter 2000. Triggers and events can be tied to the meter's standard functions such as e-mail, logs and trends. Analog outputs can be programmed to output meter parameters to BMS or PLC systems

Note

These specifications are subject to change without notice and represent the maximum capabilities of the product with all options installed. This is not a complete feature list. Features and functionality may vary depending on selected options, firmware version and product model. Please refer to the technical data sheet and User Manual for detailed specifications.

Standards and Certifications

- UL/cUL Electrical and Electronic Measuring and Test Equipment 22CZ
- Accuracy: IEC/EN60687 0.2 Class, ANSI C12.20 0.2 Class
- ANSI C62.41 Burst
- CE Mark



Catalog Number Selection

Power Xpert Meter 2000

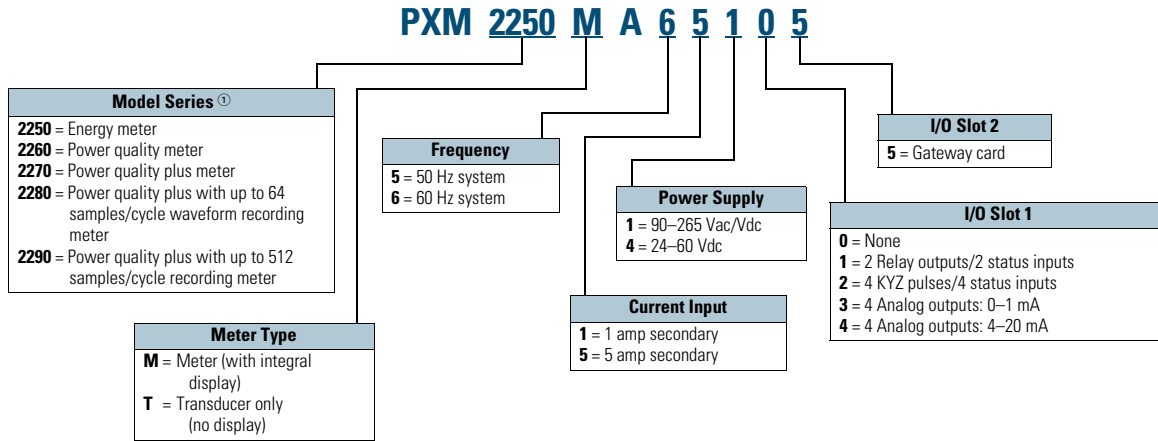

Example 1: **PXM2270MA65145** (PXM 2270 Meter/Display 60 Hz, 5A, 90–265 Vac/Vdc W/4AO)
 Example 2: **PXM2250MA65105** (PXM 2250 Meter/Display 60 Hz, 5A, 90–265 Vac/Vdc)

Note

① Refer to **Page V3-T9-29** for model-specific features.

To order a Power Xpert Meter 2000, the catalog number should be determined using the chart shown above. The chart illustrates how to include the desired factory options as part of a catalog number. Option cards that are selected at time of order entry will be installed at the factory. Option cards are also field installable for future upgrades.

Power Xpert meter modules include panel mounting brackets.

Example 1:
 PXM2270MA65145 (PXM 2270 Meter/Display 60 Hz, 5A, 90–265 Vac/Vdc W/4AO).

Example 2:
 PXM2250MA65105 (PXM 2250 Meter/Display 60 Hz, 5A, 90–265 Vac/Vdc).

Accessories

Power Xpert Meter 2000

Description	Catalog Number
Panel mounting bracket assembly for retrofitting a PXM 2000 to an IQ analyzer/IQ DP4000/IQ data cutout	IQ250-PMAK
PXM 2000 Gateway card kit to upgrade an IQ 250/260 to a PXM 2000	PXM2000-GCK

Power Xpert Meter 2000 I/O Cards

Description	Catalog Number
PXM 2000 I/O card—2 relay outputs/2 status inputs	IQ250/260-IO1
PXM 2000 I/O card—4 KYZ Pulses/4 status inputs	IQ250/260-IO2
PXM 2000 I/O card—4 analog outputs—0–1 mA	IQ250/260-IO3
PXM 2000 I/O card—4 analog outputs—4–20 mA	IQ250/260-IO4

Technical Data and Specifications

PXM 2250/2260/2270 Electronic Power Meter Technical Information

Current Inputs

- Class 10: 5 amp nominal, 10 amp maximum
- Class 2: 1 amp nominal, 2 amp maximum
- Fault current withstand:
 - 100 amps for 10 seconds
 - 300 amps for 3 seconds
 - 500 amps for 1 second
- Continuous current withstand: 20 amps for screw terminated or pass-through connections
- Programmable current: full scale to any CT ratio
- Burden: 0.005 VA per phase maximum at 11 amps
- Pickup current: 0.1% of nominal
 - Class 10: 5 mA
 - Class 2: 1 mA
- Connections:
 - Pass-through wire gauge dimension: 0.177 inches (4.5 mm)
 - Quick connect: 0.25-inch (6.35 mm) male tab

Voltage Inputs

- Range:
 - Line-to-neutral 20–576 Vac
 - Line-to-Line 0–721 Vac
- Programmable voltage range: full scale to any PT ratio
- Supported systems:
 - Three element wye, 2.5 element wye
 - Two element delta, four-wire delta systems
- Input impedance: 1 megohm/phase.
- Burden: 0.36 VA/phase maximum at 600V; 0.014 VA at 120V
- Connection: 7-pin 0.400-inch pluggable terminal block, AWG #12–26 (0.129–3.31 mm²)

Isolation

- All inputs and outputs are galvanically isolated to 2500 volts

Environmental Ratings

- Operating temperature: –20°C to +70°C
- Storage temperature: –20°C to +70°C
- Operating humidity: to 95% RH noncondensing
- Faceplate rating:
 - NEMA 12
 - Mounting gasket included

Sensing Method

- Voltage, current: true rms
- Power: sampling at over 400 samples per cycle on all channels
- Harmonics resolution: 40th order

Update Rate

- Watts, VAR and VA: 100 msec at 60 Hz
- All other parameters: 1 second at 60 Hz

Power Supply

- AC/DC voltage option: 90–265 Vac at 50/60 Hz or 100–370 Vdc, universal AC/DC supply
- DC voltage option: 18–60 Vdc
- Burden: 10 VA maximum

Serial Communications Format

- Connection type: RS-485 (through back plate)
- Com port baud rate: 9600–57,600 bauds
- Com port address: 01–247
- Data format: 8-bit, no parity
- Protocols: Modbus ASCII, RTU or DNP 3.0

Network Communications Format

- Connection type: RJ-45 10/100Base-T Ethernet network port
- Protocols: Ethernet TCP/IP, Modbus TCP, BACnet/IP, HTTP, HTTPS, NTP, SMTP, SNMP

KYZ Pulse

- Contacts: one Form A
- On resistance, maximum: 35 ohms
- Peak switching voltage: 350 Vdc
- Continuous load current: 120 mA
- Peak load current: 350 mA (10 ms)
- Off-state leakage current at 350 Vdc: 1 uA
- Opto-isolation: 3750 Vac

Wiring Diagrams

Service: Wye or Delta, Four-Wire with No PTs, Two or Three CTs

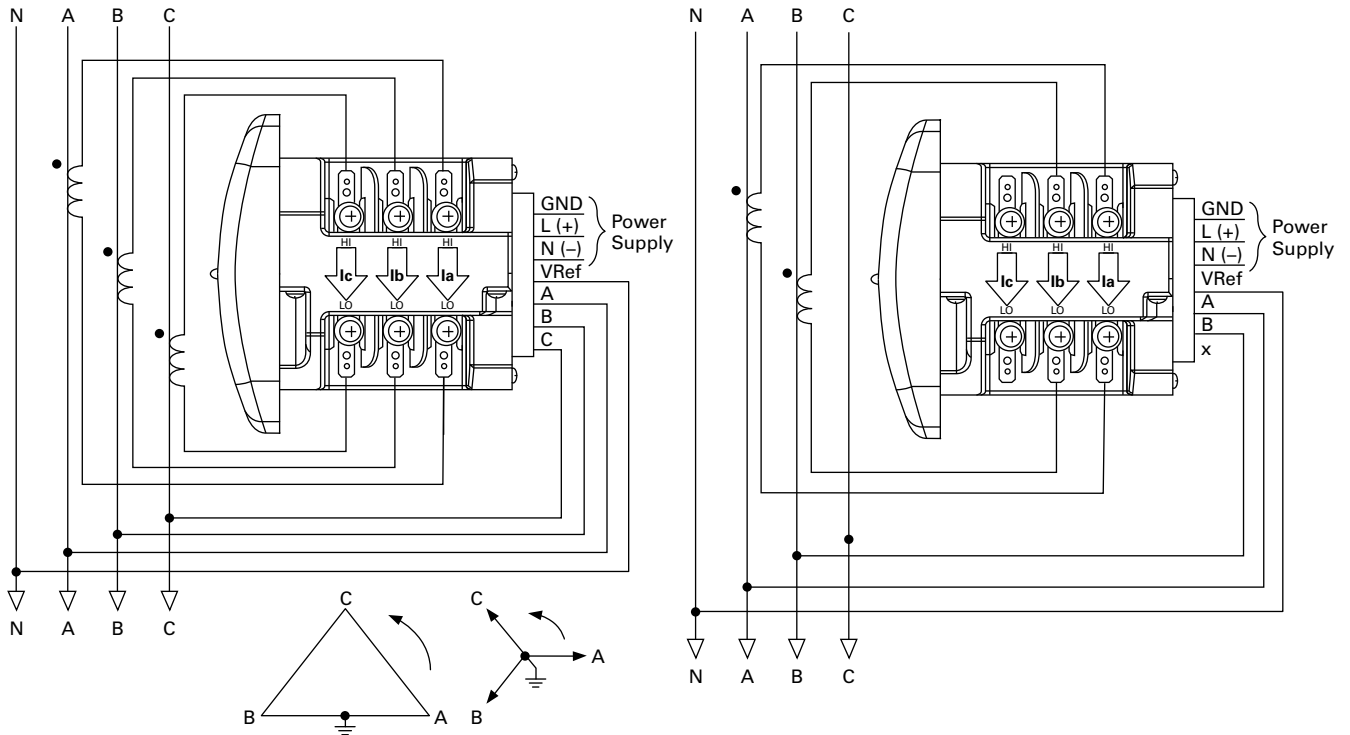

Service: Delta, Three-Wire with No PTs, 2 CTs

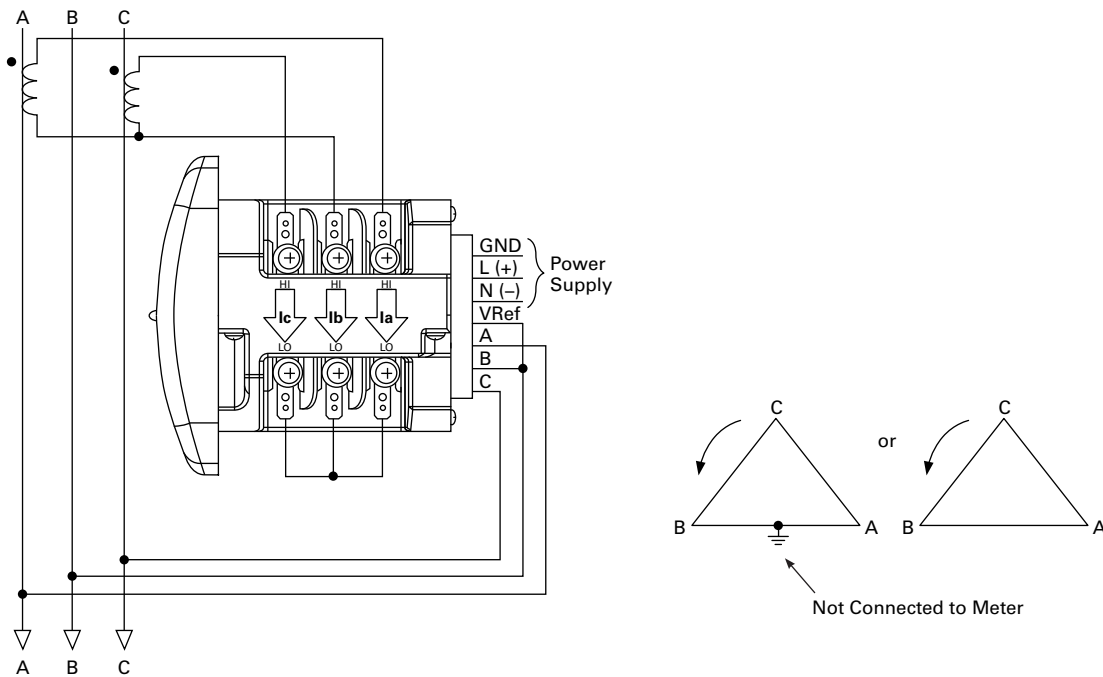

Note: Based upon the voltage rating, you may need a control power transformer for the control power.

Power Xpert Meters Configuration and Wiring Examples

PXM 2000 Display Front View

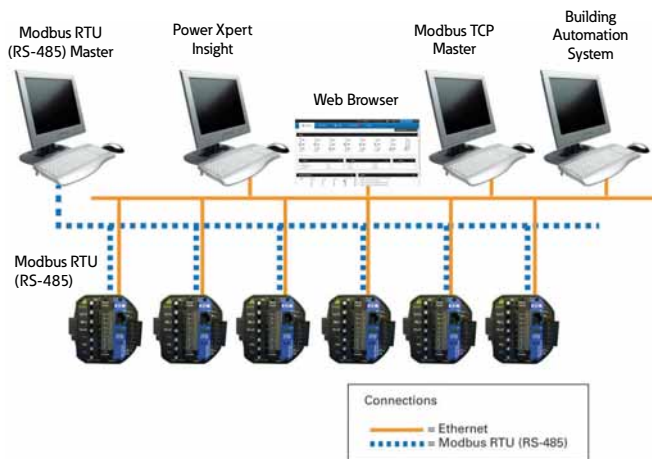

IT Configuration Examples—Accessories—I/O Cards (Option)



- Two relay programmable outputs/two programmable inputs
- Four KYZ pulses/four programmable inputs
- Four programmable analog outputs

Accessories—I/O Cards (Option)



- Two relay programmable outputs/two programmable inputs
- Four KYZ pulses/four programmable inputs
- Four programmable analog outputs

Dimensions

Approximate Dimensions in Inches (mm)

PXM 2000 Display Front View

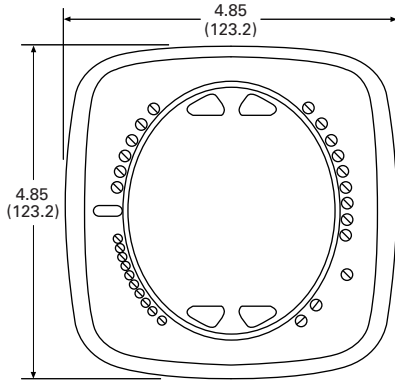

PXM 2000 Transducer Only Side View

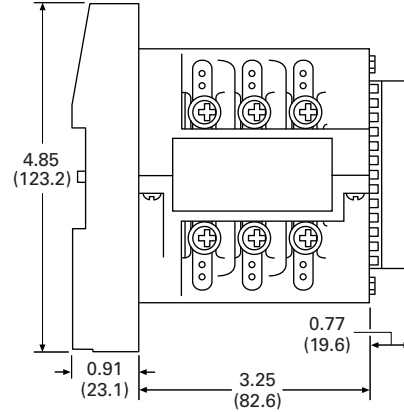

PXM 2000 Rear View

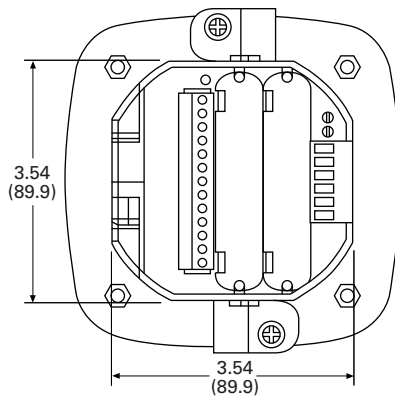

ANSI Mounting Panel Cutout

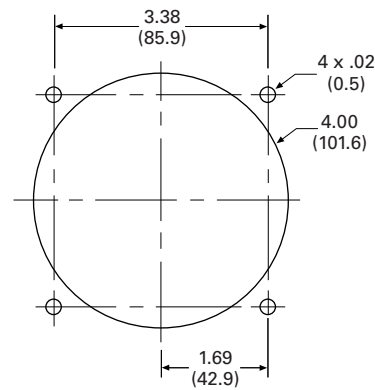

PXM 2000 Meter/Display Side View

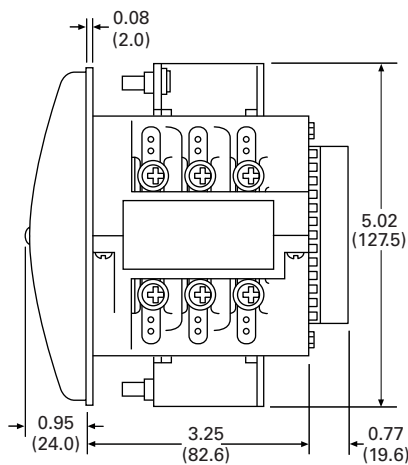

DIN Mounting Cutout

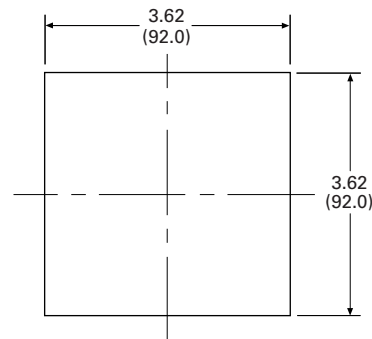

Description

Specifications

Description	Specifications
Weight	2 lbs (0.9 kg)
Basic unit	5.00 (127.0) H x 4.90 (124.5) W x 5.00 (127.0) L
PXM 2250/2260/2270	Mounts in 3.62-inch (92.0) mm DIN and ANSI C39.1 round cut-outs
Shipping container dimensions	6-inch cube
Tolerance	±0.1 inches (2.54 mm)
Projection in front of panel surface	4.85 (123.2) H x 4.85 (123.2) W x 1.01 (25.6) L
Projection behind panel surface	4.85 (123.2) H x 4.85 (123.2) W x 1.01 (25.6) L

IQ 250 and 260 Electronic Power Meters



Contents

<i>Description</i>	<i>Page</i>
Metering Products Family	V3-T9-6
Power Xpert Meter 4000/6000/8000 Series	V3-T9-13
Power Xpert Meter 2000 Series	V3-T9-26
IQ 250/260 Series Electronic Power Meters	
Standards and Certifications	V3-T9-36
Catalog Number Selection	V3-T9-37
Accessories	V3-T9-37
Technical Data and Specifications	V3-T9-38
Dimensions	V3-T9-40
IQ 130/140/150 Series Electronic Power Meters	V3-T9-41
IQ 150S/250S Self-Enclosed Electronic Meters	V3-T9-46
IQ 35M	V3-T9-51
IQ Analyzer 6400/6600 Series	V3-T9-54
IQ DP-4000 Series	V3-T9-62
Power Xpert Multi-Point Meter	V3-T9-68
PM3 Monitoring and Metering Module	V3-T9-80
Current Transformers (CTs)	V3-T9-81
Clamp-On Current Transformers	V3-T9-90
IQ Flange	V3-T9-93
Panel Mounting Adapter Kit	V3-T9-94
Enclosed Meters	V3-T9-95

IQ 250/260 Series Electronic Power Meters

Product Description

The IQ 250 and IQ 260 Meters provide capabilities you would not normally expect in affordable, ultra-compact meters, such as fast sampling rate and accurate metering for a full range of power attributes. Providing the first line of defense against costly power problems, Eaton’s IQ 250 and IQ 260 electronic power meters can perform the work of an entire wall of legacy metering equipment using today’s technology.

When space is at a premium, yet you need ANSI C12.20 accuracy, the IQ 250/ 260 series fit the bill. These meters are ideal for electrical equipment assemblies, machine control panels, such as panelboard and switchboard mains and feeders, low voltage metal-enclosed switchgear feeders and motor control centers. Requiring far less space than other meters with similar functionality, IQ 250/260 series fit into a standard ANSI or IEC cutout on a panelboard or other electrical equipment, and therefore fit easily into retrofit applications.

Application Description

- Utility and commercial metering
- Substations, industrial facilities, power generation sites and campuses
- Sub-metering
- Load studies and voltage recording
- Analog meter replacement

Features and Benefits

- Measure and display real-time information about critical power parameters with a sampling rate of 400 samples per cycle
- Monitor power utilization and quality with ANSI C12.20 accuracy (0.2 percent)
- Optional 128 KB for data logging, which guards against loss of historical data
- Verify meter accuracy with KYZ test pulse self-certification capabilities
- Standard Modbus RTU communications
- Available as transducer only or with display
- Designed to accommodate upgrades
- Integrate into Eaton’s Power Xpert architecture for a holistic system-level view

Additional Features**Features of IQ 250 and IQ 260 Electronic Power Meters**

Features	IQ 250	IQ 260
Instrumentation		
Current, per phase	■	■
Current demand	■	■
Calculated neutral current	■	■
Voltage, per phase (L-L, L-N)	■	■
Frequency	■	■
Power, Energy and Demand		
Real, reactive and apparent power, total and per phase (kW, kVAR, kVA)	■	■
Real, reactive and apparent energy, total and per phase (kWh, kVARh, kVAh)	■	■
Real, reactive and apparent power demand	■	■
Power factor, total and per phase	■	■
Min./max. readings, I, V, PF, F, THD (IQ 260), kW, kVAR, kVA	■	■
Demand Methods		
Block interval (sliding, fixed)	■	■
Communications		
RS-485	■	■
KYZ output	■	■
Modbus RTU	■	■
Modbus ASCII	■	■
DNP 3.0	■	■
Data Logging		
128 KB for data logging	Opt.	Opt.
I/O		
Two digital in /two digital out ^①	Opt.	Opt.
Four digital in/four KYZ out	Opt.	Opt.
Four analog output (4–20 mA) ^②	Opt.	Opt.
Four analog output (0–1 mA)	Opt.	Opt.
Power Quality Analysis		
Total harmonic distortion (THD) voltage and current per phase		■
Alarming		
Set point driven alarm		■

Notes

^① Digital out with IQ 250 requires external command.

^② Requires external power supply.

Standards and Certifications

- IEC 687: 0.2% accuracy
- ANSI C12.20: 0.2% accuracy
- ANSI C62.41: Burst
- UL/cUL: Electrical and electronic measuring and test equipment 22CZ



Catalog Number Selection

IQ 250/260 Meter

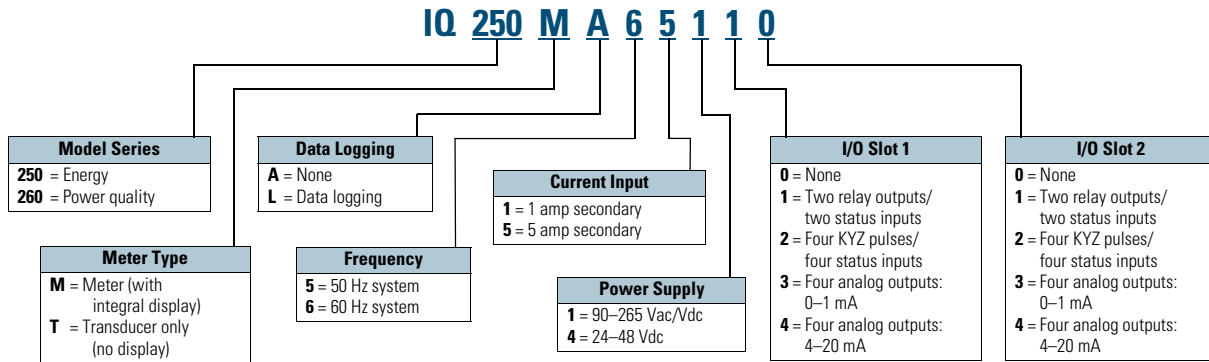

Accessories

IQ 250/260 Meter

Description	Catalog Number
Panel mounting adapter for retrofitting an IQ 250/260 to an IQ Analyzer/IQ DP-4000/IQ data cutout	IQ250-PMAK
PXM 2000 Gateway card kit to upgrade an IQ 250/260 to a PXM 2000	PXM2000-GCK

IQ 250/260 Meter I/O Cards

Description	Catalog Number
IQ 250/260 I/O card—2 relay outputs/2 status inputs	IQ250/260-I01
IQ 250/260 I/O card—4 KYZ pulses/4 status inputs	IQ250/260-I02
IQ 250/260 I/O card—4 analog outputs—0–1 mA	IQ250/260-I03
IQ 250/260 I/O card—4 analog outputs—4–20 mA	IQ250/260-I04

Technical Data and Specifications

IQ 250/260 Electronic Power Meter

Description	Specifications
Current Inputs	
Class 10	5 amp nominal, 10 amp max.
Class 2	1 amp nominal, 2 amp max.
Fault current withstand	
100 amps for:	10 seconds
300 amps for:	3 seconds
500 amps for:	1 second
Continuous current withstand	20 amps for screw terminated or pass-through connections
Programmable current	Full scale to any CT ratio
Burden	0.005 VA per phase max. at 11 amps
Pickup current	0.1% of nominal
Class 10	5 mA
Class 2	1 mA
Connections	
Pass-through wire gauge dimension	0.177 inches (4.5 mm)
Quick connect	0.25-inch male tab
Voltage Inputs	
Range	
Line-to-neutral	20–576 Vac
Line-to-line	0–721 Vac
Programmable voltage range	Full scale to any PT ratio
Supported systems	3 element wye, 2.5 element wye, 2 element delta, four-wire delta systems
Input impedance	1 meg ohm/phase
Burden	0.36 VA/phase max. at 600V; 0.014 VA at 120V
Connection	7-pin 0.400-inch pluggable terminal block, AWG #12–26 (0.129–3.31 mm ²)
Isolation	
All inputs and outputs are galvanically isolated to 2500 volts.	
Environmental Ratings	
Operating temperature	–20°C to +70°C
Storage temperature	–20°C to +70°C
Operating humidity	To 95% RH noncondensing
Faceplate rating	NEMA 12 Water-resistant Mounting gasket included

Description	Specifications
Sensing Method	
Voltage, current	True rms
Power	Sampling at over 400 samples per cycle on all channels
Harmonics resolution	40th order
Update Rate	
Watts, VAR and VA	100 msec at 60 Hz
All other parameters	1 second at 60 Hz
Power Supply	
AC/DC voltage option	90–265 Vac at 50/60 Hz or 100–370 Vdc, universal AC/DC supply
DC voltage option	18–60 Vdc
Burden	10 VA max.
Standard Communications Format	
Connection type	RS-485 (through back plate)
Com port baud rate	9600–57,600 bauds
Com port address	01–247
Data format	8-bit, no parity
Protocols	Modbus ASCII, RTU or DNP 3.0
KYZ Pulse	
Contacts	1 Form A
On resistance, max.	35 ohms
Peak switching voltage	350 Vdc
Continuous load current	120 mA
Peak load current	350 mA (10 ms)
Off-state leakage current at 350 Vdc	1 μ A
Opto-isolation	3750 Vac

Wiring Diagrams

Service: Wye or Delta, Four-Wire with No PTs, Two or Three CTs

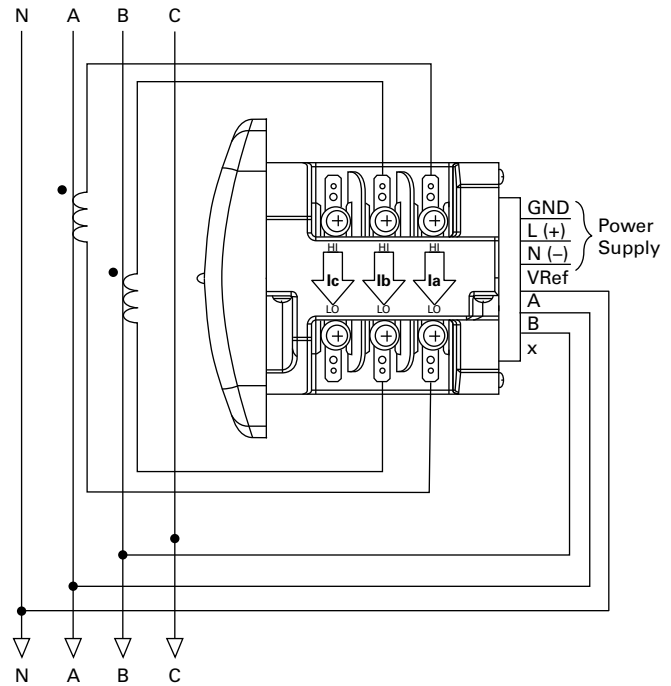
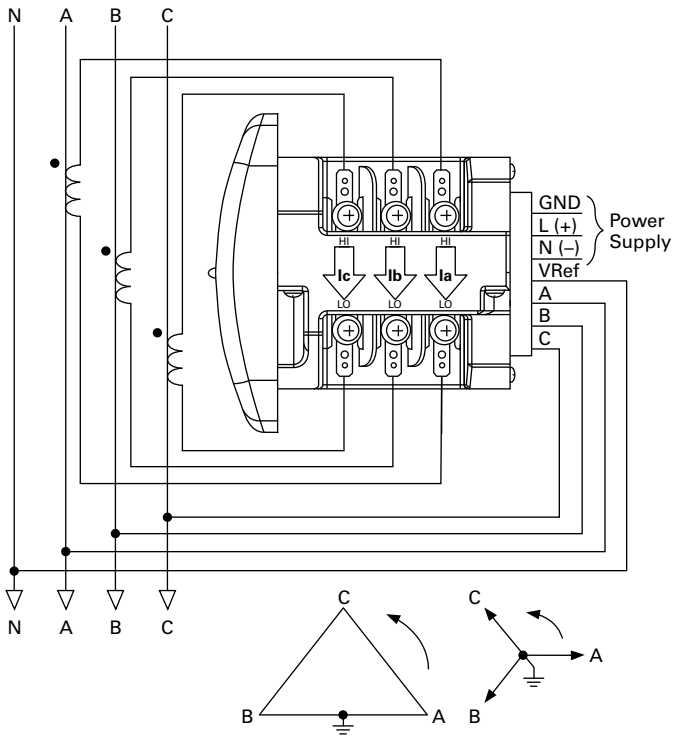

Service: Delta, Three-Wire with No PTs, 2 CTs

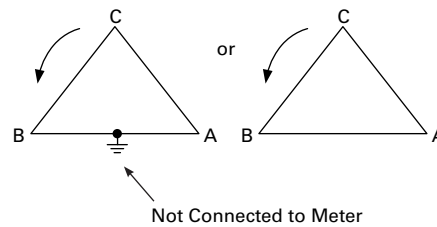
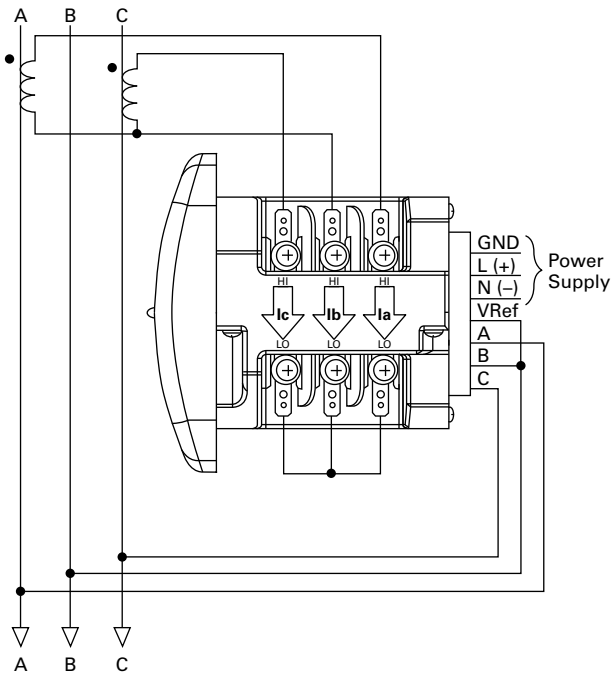

Note: Based upon the voltage rating, you may need a control power transformer for the control power.

9.2

Metering Devices, Protective Relays, Software and Connectivity

Metering Devices

Dimensions

Approximate Dimensions in Inches (mm)

IQ 250/260 Meter—Face and Side Views

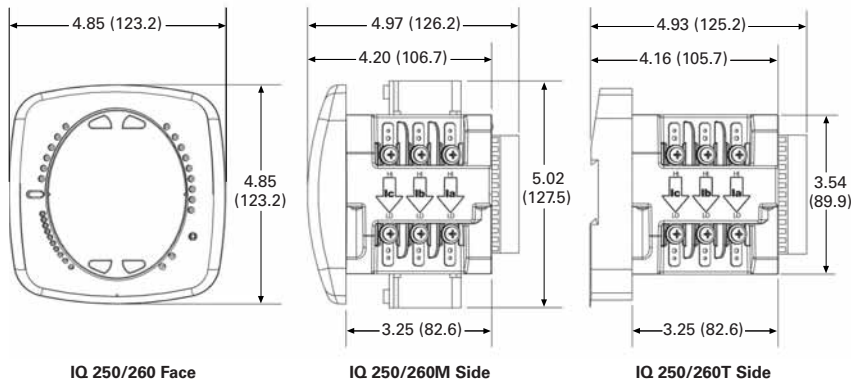

Expandable IQ Componentry

9

ANSI Mounting Panel Cutout

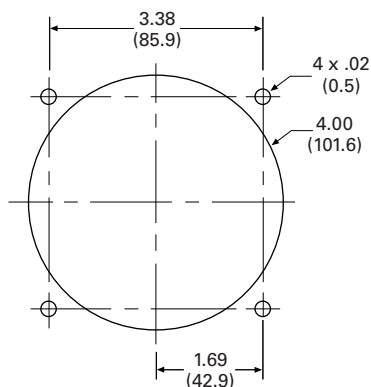

DIN Mounting Cutout

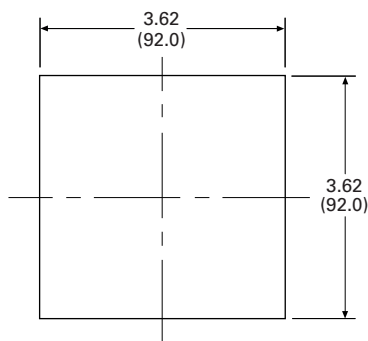

Description	Specifications
Weight	2 lbs (0.9 kg)
Basic unit	5.00 (127.0) H x 4.90 (124.5) W x 5.00 (127.0) L
IQ 250/260	Mounts in 92 mm DIN and ANSI C39.1 round cut-outs
Shipping container dimensions	6-inch cube
Tolerance	±0.1 inches (2.54 mm)
PXM 2250/2260/2270	Mounts in 3.62-inch (92.0) mm DIN and ANSI C39.1 round cut-outs
Projection in front of panel surface	4.85 (123.2) H x 4.85 (123.2) W x 1.01 (25.6) L
Projection behind panel surface	4.85 (123.2) H x 4.85 (123.2) W x 1.01 (25.6) L

IQ 100



Contents

Description	Page
Metering Products Family	V3-T9-6
Power Xpert Meter 4000/6000/8000 Series	V3-T9-13
Power Xpert Meter 2000 Series	V3-T9-26
IQ 250/260 Series Electronic Power Meters	V3-T9-35
IQ 130/140/150 Series Electronic Power Meters	
Standards and Certifications	V3-T9-42
Catalog Number Selection	V3-T9-42
Accessories	V3-T9-42
Technical Data and Specifications	V3-T9-43
Dimensions	V3-T9-45
IQ 150S/250S Self-Enclosed Electronic Meters	V3-T9-46
IQ 35M	V3-T9-51
IQ Analyzer 6400/6600 Series	V3-T9-54
IQ DP-4000 Series	V3-T9-62
Power Xpert Multi-Point Meter	V3-T9-68
PM3 Monitoring and Metering Module	V3-T9-80
Current Transformers (CTs)	V3-T9-81
Clamp-On Current Transformers	V3-T9-90
IQ Flange	V3-T9-93
Panel Mounting Adapter Kit	V3-T9-94
Enclosed Meters	V3-T9-95

IQ 130/140/150 Series Electronic Power Meters

Product Description

The IQ 100 Meter family provides capabilities you would not normally expect in affordable, compact meters, such as fast sampling rate and accurate metering for a full range of power attributes. Providing the first line of defense against costly power problems, Eaton’s IQ 100 series electronic power meters can perform the work of an entire wall of legacy metering equipment utilizing today’s technology.

When space is at a premium, yet you need ANSI C12.20 accuracy, the IQ 100 series fit the bill. These meters are ideal for electrical equipment assemblies, machine control panels, such as panelboard and switchboard mains and feeders, low voltage metal-enclosed switchgear feeders and motor control centers. Requiring far less space than other meters with similar functionality, IQ 100 series fit into a standard ANSI or IEC cutout on a panelboard or other electrical equipment, and therefore fit easily into retrofit applications.

Application Description

- Utility and commercial metering
- Substations, industrial facilities, power generation sites and campuses
- Sub-metering
- Load studies and voltage recording
- Analog meter replacement

Features and Benefits

- Measure and display real-time information about critical power parameters with a sampling rate of 400 samples per cycle
- Monitor power utilization and quality with ANSI C12.20 accuracy (0.5%)
- Verify meter accuracy with KYZ test pulse self-certification capabilities
- Optional Modbus RTU or TCP communications
- Available as transducer only or with display
- Designed to accommodate upgrades
- Integrate into Eaton’s Power Xpert Architecture for a holistic system-level view

IQ 100 Electronic Power Meters

Features	IQ 130	IQ 140	IQ 150
Instrumentation			
Current, per phase	■	■	■
Current demand	■	■	■
Calculated neutral current	■	■	■
Voltage, per phase (L-L, L-N)	■	■	■
Min./max. readings, I, V	■	■	■
Min./max. readings, I, V, PF, F, W, VAR, VA		■	■
Frequency		■	■
Power			
Real, reactive and apparent power, total (W, VAR, VA)		■	■
Power factor, total		■	■
Real, reactive and apparent power demand		■	■
Demand Methods			
Block interval (sliding, fixed)		■	■
Energy			
Real, reactive and apparent energy, total (Wh, VAR, VAh)			■
Communications			
RS-485, Modbus RTU, Modbus ASCII, KYZ output	Opt.	Opt.	Opt.
RJ45, Modbus TCP, KYZ output	Opt.	Opt.	Opt.

Standards and Certifications

- IEC 687: 0.5% accuracy
- ANSI C12.20: 0.5% accuracy
- ANSI C62.41: Burst
- CE
- UL/cUL: Electrical and Electronic Measuring and Test Equipment 22CZ



Catalog Number Selection

IQ 100 Meter

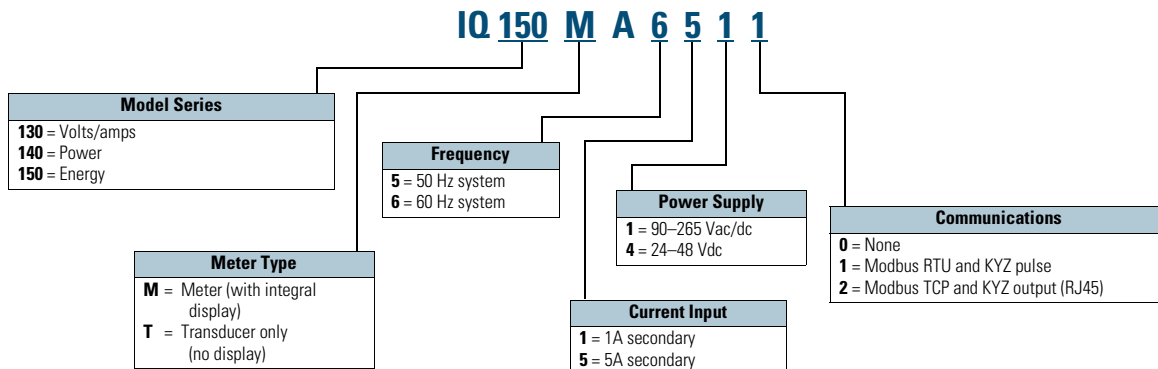

Accessories

IQ 100 Meter

Description	Catalog Number
Panel Mounting Adapter for retrofitting an IQ 100 to an IQ Analyzer/IQ DP-4000/IQ Data Cutout	IQ250-PMAK

Technical Data and Specifications

IQ 100 Electronic Power Meters

Description	Specifications
Current Inputs	
Class 10	5A nominal, 10A max.
Class 2	1A nominal, 2A max.
Fault current withstand	
100A for:	10 seconds
300A for:	3 seconds
500A for:	1 second
Continuous current withstand	20A for screw terminated or pass-through connections
Programmable current	Full scale to any CT ratio
Burden	0.005 VA per phase max. at 11A
Pickup current	0.1% of nominal
Class 10	5 mA
Class 2	1 mA
Connections	
Pass-through wire gauge dimension	0.177-inch (4.5 mm)
Quick connect	0.25-inch male tab
Voltage Inputs	
Range	
Line-to-neutral	20–416 Vac
Line-to-line	20–721 Vac
Programmable voltage range	Full scale to any PT ratio
Supported systems	3 element wye, 2.5 element wye, 2 element delta, four-wire delta systems
Input impedance	1 megohm/phase
Burden	0.36 VA/phase max. at 600V; 0.014 VA at 120 volts
Connection	7-pin 0.400-inch pluggable terminal block, AWG #12–26 (0.129–3.31 mm ²)
Isolation	
All inputs and outputs are galvanically isolated to 2500 volts.	
Environmental Ratings	
Operating temperature	–20°C to +70°C
Storage temperature	–40°C to +85°C
Operating humidity	To 95% RH noncondensing
Faceplate rating	NEMA 12 water-resistant mounting gasket included

IQ 100 Electronic Power Meters, continued

Description	Specifications
Sensing Method	
Voltage, current	True RMS
Power	Sampling at over 400 samples per cycle on all channels
Update Rate	
Watts, VAR and VA	100 msec at 60 Hz
All other parameters	1 second at 60 Hz
Power Supply	
AC/DC voltage option	90–265 Vac at 50/60 Hz or 100–370 Vdc, Universal AC/DC supply
DC voltage option	18–60 Vdc
Burden	10 VA max.
Optional Communications Format	
Connection type	RS-485 or RJ45 (through back plate)
Com port baud rate	9600–57,600 bauds
Com port address	01–247
Data format	8-bit, no parity
Protocols	Modbus ASCII, RTU, TCP
Optional KYZ Pulse	
Contacts	1 Form A
On resistance, max.	35 ohms
Peak switching voltage	350 Vdc
Continuous load current	350 mA (10 ms)
Off-state leakage current at 350 Vdc	1 uA
Opto-isolation	3750 Vac

Note

These specifications are subject to change without notice and represent the maximum capabilities of the product with all options installed. This is not a complete feature list. Features and functionality may vary depending on selected options, firmware version and product model. Please refer to the technical data sheet and User Manual for detailed specifications.

Wiring Diagrams

Service: Wye or Delta, Four-Wire with No PTs, Two or Three CTs

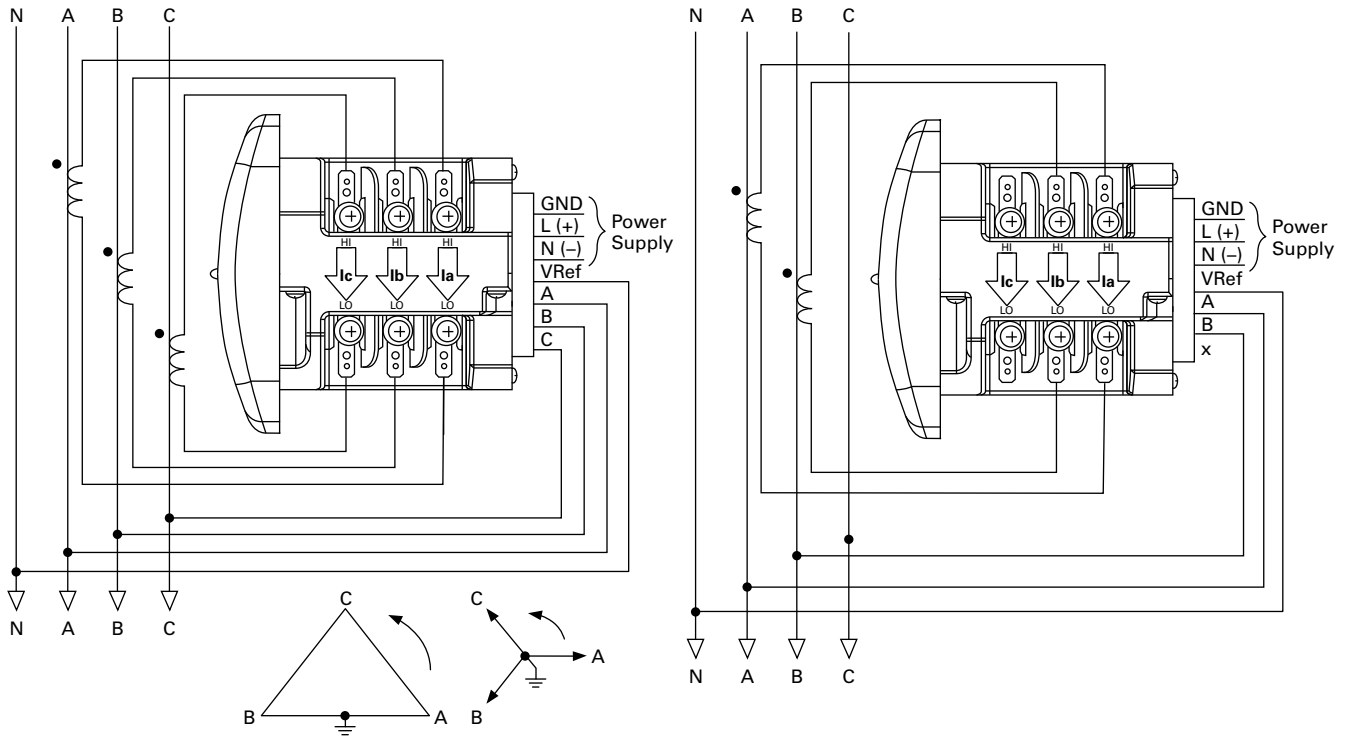

Service: Delta, Three-Wire with No PTs, 2 CTs

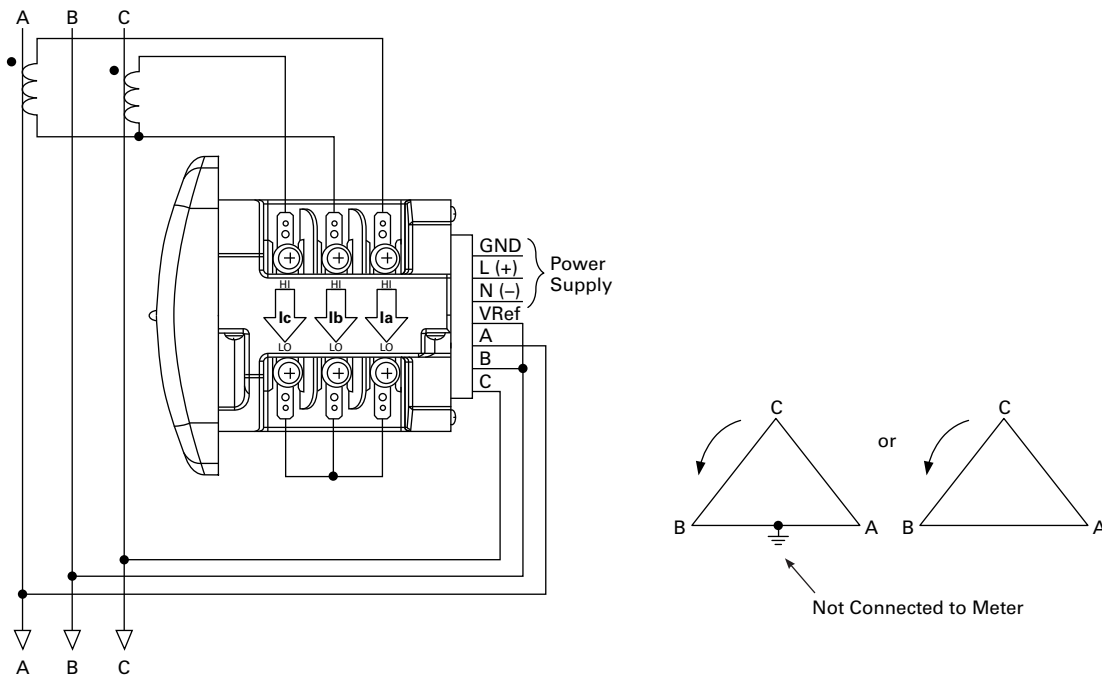

Note: Based upon the voltage rating, you may need a control power transformer for the control power.

Dimensions

Approximate Dimensions in Inches (mm)

IQ 100 Meter—Face and Side Views

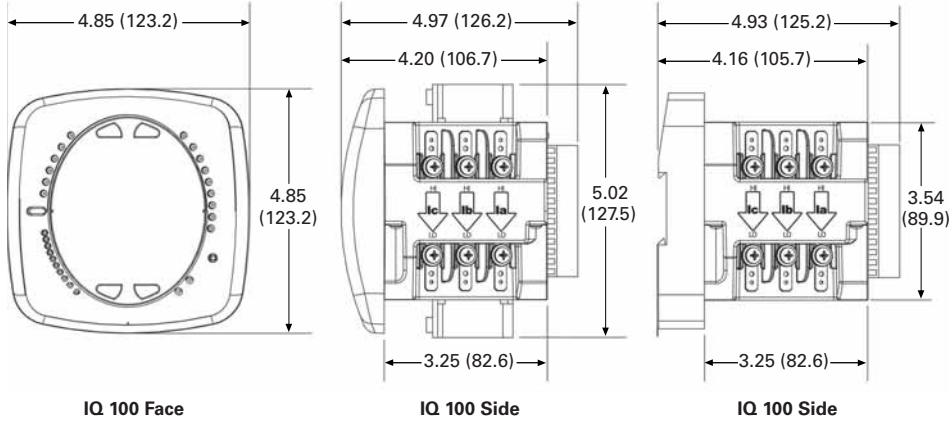

ANSI Mounting Panel Cutout

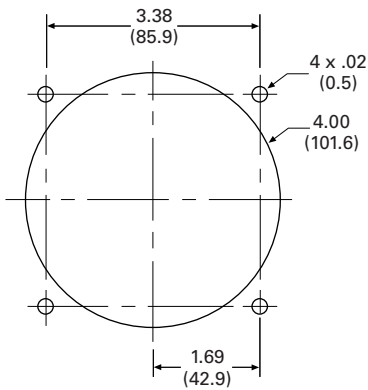

DIN Mounting Cutout

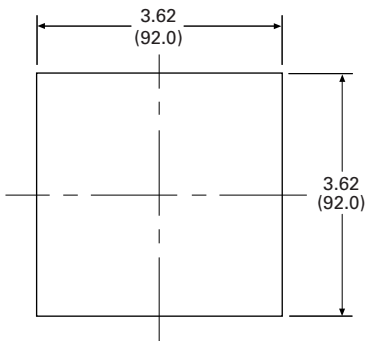

Description	Specifications
Weight	2 lbs (0.9 kg)
Basic unit	5.00 (127.0) H x 4.90 (124.5) W x 5.00 (127.0) L
IQ 100	Mounts in 92 mm DIN and ANSI C39.1 round cut-outs
Shipping container dimensions	6-inch cube
Tolerance	±0.1 inches (2.54 mm)

IQ 150S/250S Self-Enclosed Electronic Meters



Contents

<i>Description</i>	<i>Page</i>
Metering Products Family	V3-T9-6
Power Xpert Meter 4000/6000/8000 Series	V3-T9-13
Power Xpert Meter 2000 Series	V3-T9-26
IQ 250/260 Series Electronic Power Meters	V3-T9-35
IQ 130/140/150 Series Electronic Power Meters	V3-T9-41
IQ 150S/250S Self-Enclosed Electronic Meters	
Catalog Number Selection	V3-T9-48
Technical Data and Specifications	V3-T9-49
Wiring Diagrams	V3-T9-50
Dimensions	V3-T9-50
IQ 35M	V3-T9-51
IQ Analyzer 6400/6600 Series	V3-T9-54
IQ DP-4000 Series	V3-T9-62
Power Xpert Multi-Point Meter	V3-T9-68
PM3 Monitoring and Metering Module	V3-T9-80
Current Transformers (CTs)	V3-T9-81
Clamp-On Current Transformers	V3-T9-90
IQ Flange	V3-T9-93
Panel Mounting Adapter Kit	V3-T9-94
Enclosed Meters	V3-T9-95

IQ 150S/250S Self-Enclosed Electronic Meters

Product Description

With energy costs skyrocketing, you need the ability to verify the accuracy of utility billing and allocation of energy costs among business units, different manufacturing areas or facilities, and tenants. Production equipment and IT systems are vulnerable to power anomalies; therefore, you must ensure that power is always up to specifications. If your infrastructure is an established facility, you may not currently have metering or may have addressed these concerns by deploying a variety of analog gauges and meters—one for volts, one for amperes and so on, with separate meters for each measurement.

If you're planning an upgrade or a new power infrastructure, no doubt you would like to capitalize on the latest technology to improve upon that cumbersome architecture and its patchwork view.

Application Description

- Industrial and commercial buildings, metering and submetering
- Government facilities and military
- Universities and airports
- Load studies and voltage recording

Features and Benefits

- Self-enclosed, these meters are an ideal solution for surface mounting next to a selected piece of equipment for energy monitoring
- NEMA 12 enclosure with a large, easy-to-read faceplate, consistent with other Eaton meter models, designed with "knockouts" for easy installation
- Ethernet communications option for either wired or wireless setup, allowing for additional ease of installation and integration into existing networks
- Available data and alarm recording for historical records/trending

- Integrate into Eaton's Power Xpert® Architecture for a holistic system-level view

Wireless and High-End Capabilities you would not Expect from a Self-Enclosed, Compact Meter

Providing the first line of defense against costly power problems, Eaton's IQ 150S/250S electronic self-enclosed meters can perform the work of an entire wall of legacy metering equipment using today's secure wireless technology. Eaton's IQ 150S/250S meters use 24-bit AD converters that sample at more than 400 samples per cycle and meet IEC 687 (0.2% accuracy) and ANSI C12.20 (0.2% accuracy) standards. With such high-performance measurement capability, these meters can be confidently used for primary revenue metering and submetering applications.

Either model will help you monitor energy demand, while the IQ 250S provides

the extra benefit of also monitoring and recording the changes in the characteristics of your power.

Eaton's IQ 150S/250S meters provide direct-reading metered values for the most critical power aspects, such as watts, watt demand, watthours, voltage amperes (VA), VA-hours, VARs, VAR-hours and power factor. They have high sampling speed and accuracy.

These meters are self-enclosed in a NEMA 12 enclosure with "knockouts" on the bottom for communication and power, providing for an easy installation.

Perhaps you don't have network drops in all the right places. The IQ 150S/250S offers a wireless communications option. The transmissions are encrypted using 128-bit Wired Equivalent Privacy (WEP) for security.

Industry-Standard Communication Protocols
Standard Modbus RS-485 Communication

Standard communication includes an RS-485 output speaking Modbus protocol. This allows the unit to be connected to any serial RS-485 bus using the Modbus interface. The unit communicates easily with most building automation, Power Xpert Insight or other software systems. Baud rates are up to 57.6K baud to provide fast update times.

Wi-Fi or Land-Based Ethernet

The unit offers an Ethernet option—configured either as an RJ45 or Wi-Fi connection. The Wi-Fi configuration allows the 150S/250S to be used on standard Wi-Fi base stations. The unit is assigned an IP address; it communicates Modbus protocol over Ethernet TCP/IP. Wireless Ethernet is reliable and easy to integrate, making it the superior solution for mass meter deployment.

KYZ Pulse

For applications in which a pulse is needed, the unit also provides a KYZ output that pulses proportional to the amount of energy consumed. This feature is used for pulse counting applications into building management systems where serial or Ethernet protocol is not available.

Verify Energy Bills

The IQ 150S/250S models provide a traceable watthour test pulse (used with a watthour pulse recorder or totalizer), so you can verify the accuracy of your meter and in turn, the accuracy of billing from your utility company and to internal customers.

Integrated with Eaton’s Power Xpert Architecture

IQ 150S/250S meters integrate into Eaton’s Power Xpert Architecture, where meters, gateways and monitoring devices collaborate to create a unified, centralized view of the end-to-end power and facility infrastructure.

When used in this architecture, either with a Power Xpert Gateway or directly via Ethernet, the meters with the Modbus RTU option can provide Web-based graphics of current power conditions. Simply connect your meter to a Power Xpert Gateway to translate Modbus-based information from the meter into HTML-based Web pages that are accessible from any standard Web browser. If you select a model with the Ethernet option, the meter can easily be monitored remotely via Power Xpert Insight or another third-party monitoring system. With access to accurate, real-time information from IQ 150S/250S meters, Power Xpert Architecture can transform your power system into an integrated, agile system, and an easily managed entity that performs better and costs less.

Designed for the User

When space is at a premium, yet you need ANSI C12.20 accuracy, Eaton IQ 150S/250S meters fit the bill. These ultra-compact meters are ideal for surface mounting next to a selected piece of equipment for energy monitoring. Requiring far less space than other meters with similar functionality, and offering a NEMA 12 enclosure and a large, easy-to-read faceplate, consistent with other Eaton meter models, these meters are designed with “knockouts” for easy retrofit installation.

Most meters in this class have small or dark displays that can be hard to see, especially from a distance. Eaton’s IQ 150S/250S meters have a large, bright red, three-line LED display, each line more than a half-inch tall. This display is very easy to read, even if the meter is installed at a height or distance. Using the keypad and menus on the local display, users can display a variety of electrical system values or program the meter.

Installation Diagram

IQ 150S/250S Installation

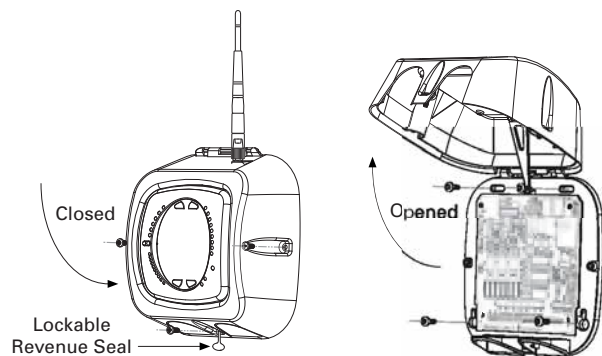

Features of IQ 150S/250S Electronic Power Meters

Features	IQ 150S	IQ 250S
Instrumentation		
Current, per phase	■	■
Calculated neutral current	■	■
Voltage, per phase (L-L, L-N)	■	■
Frequency	■	■
Minimum/maximum readings, I [Ⓢ] , V [Ⓢ] , PF, F, W, VAR, VA	Total	Total and per phase
Power		
Real, reactive and apparent power (W, VAR, VA)	Total	Total and per phase
Power factor	Average	Average and per phase
Demand Methods		
Block interval (fixed, sliding)	■	■
Current demand	■	■
Real, reactive and apparent power demand	Total	Total and per phase
Energy		
Real, reactive and apparent energy (Wh, VARh, VAh)	Total	Total and per phase
Real and reactive, net and positive and negative (Wh, VARh)	Total	Total and per phase
I/O		
Pulse output	■	■
Communications		
RS-485, Modbus RTU, DNP 3.0	■	■
RJ45 or 802.11b, Modbus TCP [Ⓢ]	Optional	Optional
Data Logging		
2 MB for data logging		■
Alarming		
Set point driven alarm		■

Notes

- Ⓢ Per phase only.
- Ⓢ If configured for Ethernet, RS-485 not available.

Catalog Number Selection

IQ 150S/250S Meter

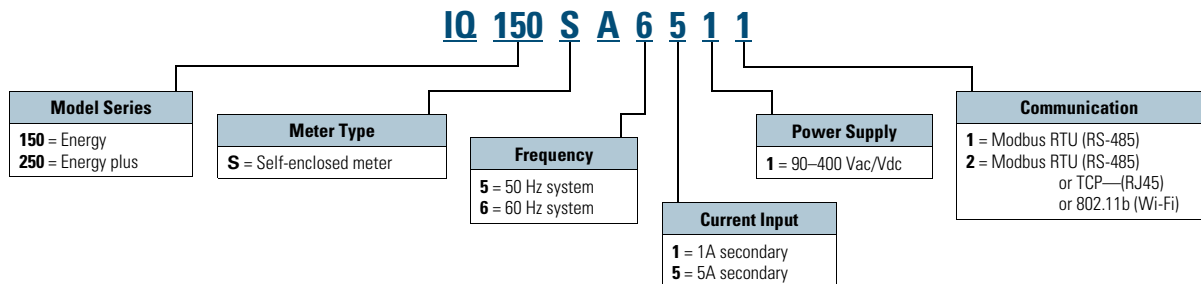

Technical Data and Specifications

IQ 150S/250S Electronic Meter Technical Information

Description	Specifications
Current Inputs	
Class 10	5A nominal, 10A maximum
Class 2	1A nominal, 2A maximum
Fault Current Withstand	
20A for:	10 seconds
60A for:	3 seconds
100A for:	1 second
Programmable current	Full scale to any CT ratio
Burden	0.005 VA per phase maximum at 11A
Pickup Current	
Class 10	0.1% of nominal
Class 2	5 mA
	1 mA
Connections	
Screw terminal	#6–32 screws
Voltage Inputs	
Range	
Line-to-neutral	20–416 Vac (IQ150S), 20–576 Vac (IQ250S)
Line-to-line	20–721 Vac
Programmable voltage range	Full scale to any PT ratio
Supported systems	3 element wye, 2.5 element wye, 2 element delta, four-wire delta systems
Input impedance	1 megohm/phase
Burden	0.36 VA/phase maximum at 600V; 0.014 VA at 120V
Connection	7-pin, 0.400-inch screw terminal block, AWG #12–26 (0.129–3.31 mm ²)
Isolation	
All inputs and outputs are galvanically isolated to 2500V	
Environmental Ratings	
Operating temperature	–20° to +70°C
Storage temperature	–20° to +70°C
Operating humidity	To 95% RH noncondensing
Faceplate rating	NEMA 12
Sensing Method	
Voltage, current	rms
Power	Sampling at over 400 samples per cycle on all channels

Description	Specifications
Update Rate	
Watts, VAR and VA	100 msec at 60 Hz
All other parameters	1 second at 60 Hz
Power Supply	
AC/DC voltage option	90–400 Vac at 50/60 Hz or 100–370 Vdc, universal AC/DC supply
Burden	16 VA maximum
Standard Serial Communications Format	
Connection type	RS-485
Communications port baud rate	9600–57,600 Bauds
Communications port address	01–247
Data format	8-bit, no parity
Protocols	Modbus ASCII, RTU, DNP 3.0
Optional Ethernet Communications Format	
Connection type	RJ45 or 802.11b (wireless)
Protocols	Modbus TCP
KYZ Pulse	
Contacts	1 Form A
On resistance, maximum	35 Ohms
Peak switching voltage	350 Vdc
Continuous load current	120 mA
Peak load current	350 mA (10 ms)
Off-state leakage current at 350 Vdc	1 uA
Opto-isolation	3750 Vac
Dimensions and Shipping	
Weight	4 lbs
Basic unit	H 7.90 x W 7.50 x D 3.10 inches
Compliance	
IEC 687	0.2% accuracy
ANSI C12.20	0.2% accuracy
ANSI C62.41	Burst
ANSI (IEEE) C37.90.1	Surge withstand
UL/cUL	Electrical and electronic measuring and test equipment 22CZ

Note: Specifications are subject to change without notice and represent the maximum capabilities of the product with all options installed. This is not a complete feature list. Features and functionality may vary depending on selected options, firmware version and product model. Please refer to User Manual for detailed specifications.

Wiring Diagrams

IQ 150S/250S Electronic Meter

9

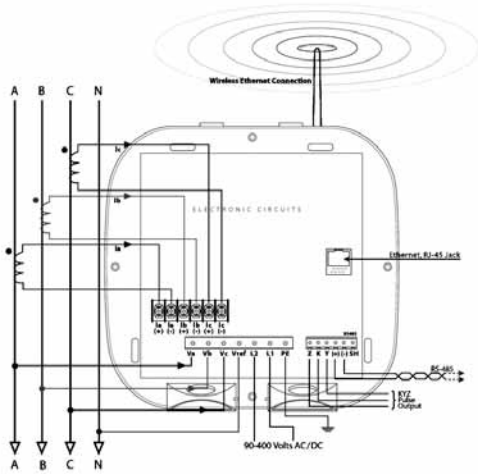

Three-Phase Four-Wire WYE Direct

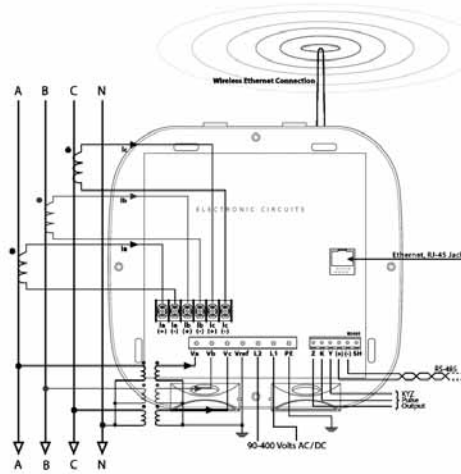

Three-Phase Four-Wire WYE with PTS

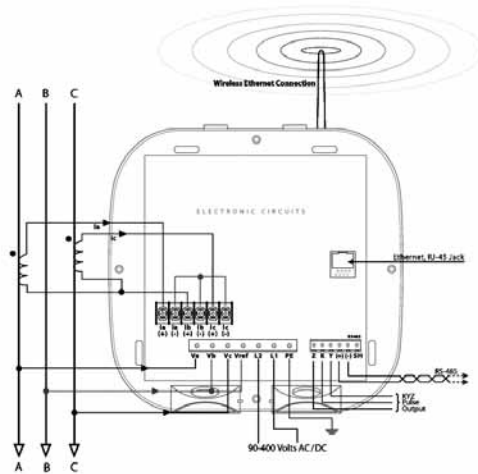

Three-Phase Three-Wire DELTA Direct

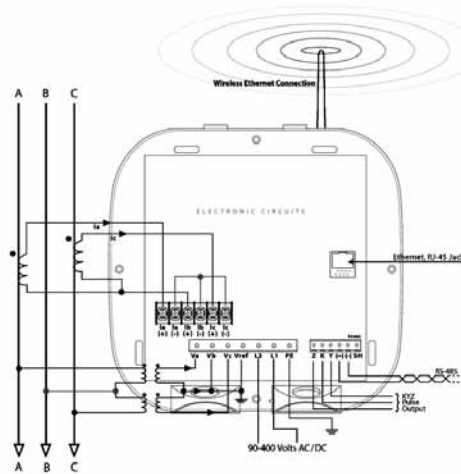

Three-Phase Three-Wire DELTA Direct

Dimensions

Approximate Dimensions in Inches (mm)

IQ 150S/250S Electronic Meter

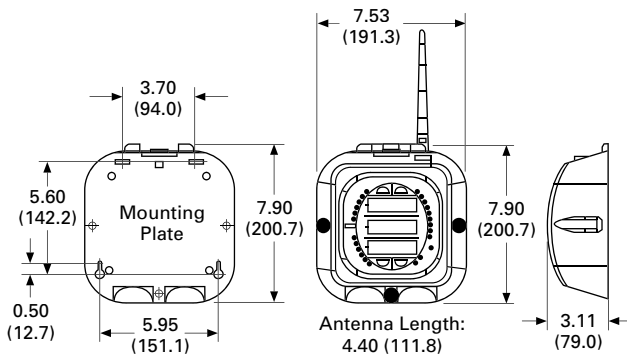

IQ 35M



Contents

<i>Description</i>	<i>Page</i>
Metering Products Family	V3-T9-6
Power Xpert Meter 4000/6000/8000 Series	V3-T9-13
Power Xpert Meter 2000 Series	V3-T9-26
IQ 250/260 Series Electronic Power Meters	V3-T9-35
IQ 130/140/150 Series Electronic Power Meters	V3-T9-41
IQ 150S/250S Self-Enclosed Electronic Meters	V3-T9-46
IQ 35M	
Product Selection	V3-T9-52
Accessories	V3-T9-52
Technical Data and Specifications	V3-T9-52
Dimensions	V3-T9-53
IQ Analyzer 6400/6600 Series	V3-T9-54
IQ DP-4000 Series	V3-T9-62
Power Xpert Multi-Point Meter	V3-T9-68
PM3 Monitoring and Metering Module	V3-T9-80
Current Transformers (CTs)	V3-T9-81
Clamp-On Current Transformers	V3-T9-90
IQ Flange	V3-T9-93
Panel Mounting Adapter Kit	V3-T9-94
Enclosed Meters	V3-T9-95

IQ 35M

Product Description

The Eaton IQ 35M Meter is a DIN rail meter that combines exceptional performance and easy installation to deliver a cost-effective solution for energy and power monitoring applications, as well as sub-metering applications. Most models include pulse output, alarm contact and phase alarms for true versatility. The BACnet version offers two digital inputs for accumulating other meter pulses in place of the digital output and alarm contact. The Modbus output options offer added flexibility for configuration and data analysis. The IQ 35M allows you to:

- Verify energy bills
- Make informed load shifting and shedding decisions
- Fairly and accurately allocate energy costs to users
- Identify wasteful practices
- Decrease unnecessary usage
- Produce an energy profile
- Secure the optimum utility rate structure

Application Description

- Commercial submetering
- Energy management
- Industrial monitoring
- Cost allocation

Features

- Economical and compact watt-hour meter with demand
- Backlit LCD display for local reading
- Compatible with the Power Xpert Gateway for remote monitoring
- Monitors
 - Voltage, current, power factor, frequency
 - Power and energy: real, reactive and apparent
- Optional data logging capability
- Optional serial communications (Modbus-RTU or BACnet)
- Revenue grade, ANSI C12.20 0.5% accuracy, IEC 62053-22 Class 0.5S
- Compatible with economical solid-core and split-core CTs
- User-enabled password protection
- On-board diagnostics

Catalog Number Selection

IQ 35M Meter

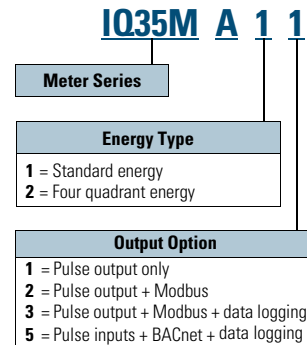

Product Selection

IQ 35M Current Transformers

Description	Catalog Number
Solid Core	
IQ35M CT, solid core, 5A:0.33 Vac, 0.30 inch	IQ35M-SO-030-5
IQ35M CT, solid core, 20A:0.33 Vac, 0.30 inch	IQ35M-SO-030-20
IQ35M CT, solid core, 50A:0.33 Vac, 0.50 inch	IQ35M-SO-050-50
IQ35M CT, solid core, 50A:0.33 Vac, 0.75 inch	IQ35M-SO-075-50
IQ35M CT, solid core, 100A:0.33 Vac, 1.25 inch	IQ35M-SO-125-100
IQ35M CT, solid core, 200A:0.33 Vac, 1.25 inch	IQ35M-SO-125-200
IQ35M CT, solid core, 250A:0.33 Vac, 1.25 inch	IQ35M-SO-125-250
IQ35M CT, solid core, 300A:0.33 Vac, 1.25 inch	IQ35M-SO-125-300
IQ35M CT, solid core, 400A:0.33 Vac, 1.25 inch	IQ35M-SO-125-400
Split Core	
IQ35M CT, split core, 5A:0.33 Vac, 0.75 inch	IQ35M-SP-075-5
IQ35M CT, split core, 30A:0.33 Vac, 0.75 inch	IQ35M-SP-075-30
IQ35M CT, split core, 50A:0.33 Vac, 0.75 inch	IQ35M-SP-075-50
IQ35M CT, split core, 100A:0.33 Vac, 0.75 inch	IQ35M-SP-075-100
IQ35M CT, split core, 200A:0.33 Vac, 0.75 inch	IQ35M-SP-075-200
IQ35M CT, split core, 250A:0.33 Vac, 1.25 inch	IQ35M-SP-125-250
IQ35M CT, split core, 300A:0.33 Vac, 1.25 inch	IQ35M-SP-125-300
IQ35M CT, split core, 400A:0.33 Vac, 1.25 inch	IQ35M-SP-125-400
IQ35M CT, split core, 600A:0.33 Vac, 1.25 inch	IQ35M-SP-125-600
IQ35M CT, split core, 800A:0.33 Vac, 2.50 inch	IQ35M-SP-253-800
IQ35M CT, split core, 1000A:0.33 Vac, 2.50 inch	IQ35M-SP-255-1000
IQ35M CT, split core, 1200A:0.33 Vac, 2.50 inch	IQ35M-SP-255-1200
IQ35M CT, split core, 1600A:0.33 Vac, 2.50 inch	IQ35M-SP-255-1600
IQ35M CT, split core, 2000A:0.33 Vac, 2.50 inch	IQ35M-SP-255-2000
IQ35M CT, split core, 2400A:0.33 Vac, 2.50 inch	IQ35M-SP-255-2400

Accessories

IQ 35M Accessories

Description	Catalog Number
IQ35M enclosure, NEMA 4X	IQ35M-ENC
IQ35M fuse pack, single, 1/2A slow-blow	IQ35M-FP1
IQ35M fuse pack, double, 1/2A slow-blow	IQ35M-FP2
IQ35M fuse pack, triple, 1/2A slow-blow	IQ35M-FP3
IQ35M replacement mounting clips	IQ35M-RMC
IQ35M DIN rail	IQ35M-DR
IQ35M DIN rail stop clips (10 pack)	IQ35M-DRSC

Note: Specifications are subject to change without notice and represent the maximum capabilities of the product with all options installed. This is not a complete feature list. Features and functionality may vary depending on selected options, firmware version and product model. Please refer to User Manual for detailed specifications.

Technical Data and Specifications

- Voltage input
 - UL: 90V (L-N) to 600V (L-L)
 - CE: 90V (L-N) to 300V (L-L)
- Current input
 - Scaling: 5–32,767A
 - Input range: 0–0.333V or 0–1V (selectable)
- Control power
 - UL: 90V (L-N) to 600V (L-L)
 - CE: 90V (L-N) to 300V (L-L)

Accuracy

- Real power and energy
 - 0.5% (ANSI C12.20, IEC 62053-22 Class 0.5S)

Outputs

- IQ35MAx1 thru 3:
 - Real energy pulse: NO static; alarm contacts: NC static
- IQ35MA11
 - Reactive energy pulse 30 Vac/Vdc
- IQ35MAx2, IQ35MAx3
 - RS-485 two-wire Modbus RTU
- IQ35MA15 RS-485 two-wire BACnet MS/TP

Inputs

- IQ35MA15
 - Two pulse accumulators

Mechanical

- Mounting
 - DIN rail or 3-point screwmount

Environmental

- Operating temperature range
 - Meter: –30° to 70°C (–22° to 158°F)
 - Display: –10° to 50°C (14° to 122°F)
- Storage temperature range
 - Meter: –40° to 85°C (–40° to 185°F)
 - Display: –10° to 60°C (14° to 140°F)
- Humidity range
 - <95% RH noncondensing

Data Outputs

- kW, kWh: Total
- Current: Three-phase average and per phase
- Voltage: Three-phase average, per phase, and line-line and line-neutral
- Power: Real, reactive and apparent; Three-phase total and per phase
- Power factor: Three-phase average and per phase
- Frequency
- Power demand: most recent and peak
- Demand configuration: fixed, rolling block and external sync
- Data logging (IQ35MAx3)
 - 10 configurable data buffers;
 - configurable demand subinterval (when set at a 15-minute interval, buffers store data for 60 days)
- Data logging (IQ35MA15)
 - 6 configurable data buffers;
 - configurable demand subinterval (when set at a 15-minute interval, buffers store data for 60 days)
- Trending requires communication network to retrieve data

Dimensions

Approximate Dimensions in Inches (mm)

IQ 35M Dimensional Drawing

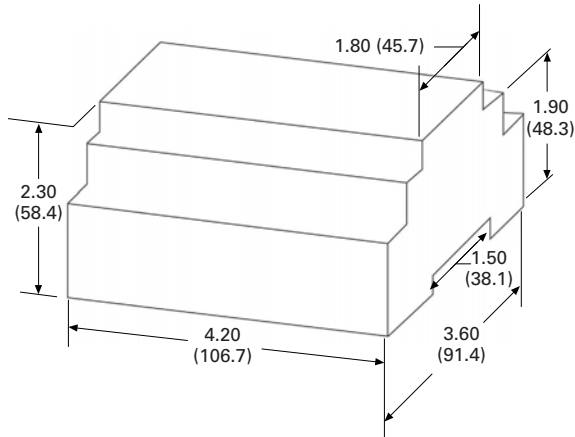

IQ 35M Wall Mount Configuration

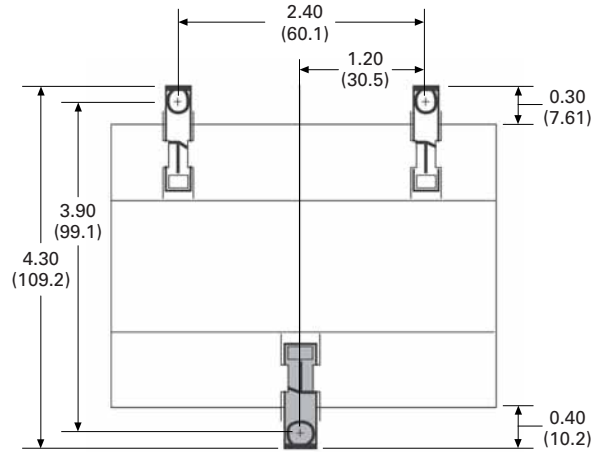

IQ 35M DIN Mount Configuration

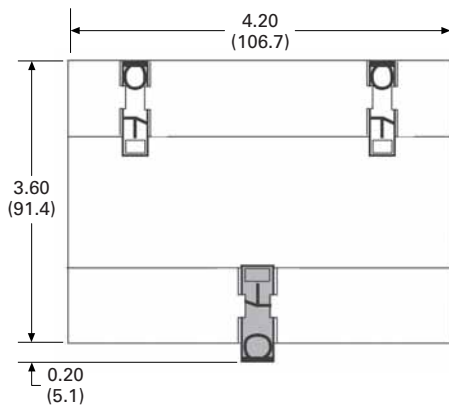

IQ Analyzer 6400/6600 Series



**IQ Analyzer—
Comprehensive Electrical
Distribution Monitoring**

IQ Analyzer 6400/6600 Series

Product Description

Eaton's IQ Analyzer is a complete solution for users who want to monitor and manage all aspects of their electrical distribution system. Based on input from customers and consultants, it provides extensive metering, power quality analysis, remote input monitoring, control relaying, analog input/outputs and communications capability.

Its high performance metering exceeds ANSI C12.16 (1%) specification for revenue meters and meets ANSI C12.20 Class 0.5%, provides quality true rms readings through the 50th harmonic, accurately measures nonsinusoidal waveforms up to a 3.0 crest factor, and displays even and odd multiples of the fundamental current and voltage through the 50th harmonic. Both magnitude and phase angle of the harmonics are displayed.

The unique operator interface, which includes a reverse mode LCD display, easy to use *Meter Menu* screens and detailed *Analysis* screens, is designed to allow a wealth of real-time and recorded information to be accessed easily by an operator. All programming can be accomplished through the faceplate or the communications port. The comprehensive on-line Help feature provides useful information on device operation, programming and troubleshooting.

Application Description

- Monitoring of over 150 electrical parameters
- Power quality management
- Energy management

Contents

<i>Description</i>	<i>Page</i>
Metering Products Family	V3-T9-6
Power Xpert Meter 4000/6000/8000 Series	V3-T9-13
Power Xpert Meter 2000 Series	V3-T9-26
IQ 250/260 Series Electronic Power Meters	V3-T9-35
IQ 130/140/150 Series Electronic Power Meters	V3-T9-41
IQ 150S/250S Self-Enclosed Electronic Meters	V3-T9-46
IQ 35M	V3-T9-51
IQ Analyzer 6400/6600 Series	
Standards and Certifications	V3-T9-57
Product Selection	V3-T9-58
Accessories	V3-T9-58
Technical Data and Specifications	V3-T9-59
Dimensions	V3-T9-60
IQ DP-4000 Series	V3-T9-62
Power Xpert Multi-Point Meter	V3-T9-68
PM3 Monitoring and Metering Module	V3-T9-80
Current Transformers (CTs)	V3-T9-81
Clamp-On Current Transformers	V3-T9-90
IQ Flange	V3-T9-93
Panel Mounting Adapter Kit	V3-T9-94
Enclosed Meters	V3-T9-95

Features, Benefits and Functions

Metered and Monitored Parameters

- rms sensing
- Phase neutral, and ground currents
- Volts: L-L, L-N, Avg. L-L, Avg. L-N, N-G
- Power: real, reactive, apparent (system and per phase)
- Frequency
- Power factor: apparent and displacement (system and per phase)
- Energy and demand (forward, reverse, net) real, reactive apparent at four different utility rates
- Individual current and voltage harmonics: magnitude, phase angle
- % THD: current and voltage
- Waveform capture

- Minimum and maximum values
- Event logging/disturbance recording
- ANSI C12.20 Class 0.5% revenue metering accuracy, IEC687 Class 0.5%
- Industry Canada 0.5% revenue accuracy

Communications

- Optional interface capability to computer network for data collection, storage and/or printout via Eaton's Power Management Software

Physical Characteristics

- Graphical reverse mode LCD display with LED backlight
- Up to seven lines of information
- Membrane faceplate NEMA 3R and 12 rated

Disturbance Information

With the communications option and Eaton's Power Management Software and Waveform Display software, a *Waveform Analysis* will construct waveforms of up to 56 cycles of all currents and voltages (including neutral and ground) to help troubleshoot undervoltage/sag and overvoltage/swell conditions. (See CBEMA Trend Logging section.) By programming a reset threshold, the duration of the voltage disturbance can also be indicated.

The IQ Analyzer 6600 series with Graphic Waveform Display offers the ability to view the captured waveform right at the device. The 6600 series also offers the ability to detect and capture sub-cycle voltage disturbances.

Extensive Harmonic Distortion Analysis

Current and voltage distortion data are displayed at the device and accessible through the communications port. This includes % THD, K-Factor, Crest Factor, CBEMA factor, and both magnitudes and phase angles of all harmonics through the 50th. A snapshot sample of this information may be activated by user commands, discrete inputs or programmable thresholds to capture distortion data during conditions of real interest. To help eliminate nuisance alarms, harmonic distortion information can be captured and relay outputs activated when THD exceeds a programmable percentage of fundamental or a programmable magnitude (e.g., amperes) threshold.

Time-of-Use Metering

The IQ Analyzer offers the ability to store energy usage data for time of use revenue metering. It can be programmed for any combination of weekday, Saturday, Sunday, 22 holidays, 8 seasons,

32 schedules and 10 time periods per schedule. The IQ Analyzer will keep track of the following parameters for four different utility rates:

- Watthours
- VAR hours
- VA hours
- Current demand
- Watt demand
- VA demand
- VAR demand

Historical Trend Logging

The IQ Analyzer is equipped with onboard logging capability, which includes the ability to log a total of 24 parameters with intervals ranging from 0.13 seconds (every eight cycles) to twice a week (5040 minutes). The trending function can begin immediately or can be triggered upon receipt of a discrete input into the IQ Analyzer. Onboard logging provides a cost-effective means of distributed data storage where real-time communications may not be feasible or for applications where data storage redundancy is desired. Four trend data logs are stored in non-volatile memory aboard the IQ Analyzer and can be retrieved at the display or via communications for viewing using Eaton's Power Management Software.

- Up to 24 parameters with storage capacity for up to 90,000 data points
- Up to 234 days of data can be stored when recording a parameter every 15 minutes
- Trends 1, 2 and 3 can save data on a discrete contact input
- Trend 4 can save data on a power quality or meter event
- Minimum and maximum recording (minimum and maximum three-phase average current, maximum I_G , minimum and maximum three-phase average V_{LL} and V_{LN} , maximum V_{NG} , maximum

system watts, VARs and VA, minimum and maximum apparent and displacement PF). Using this feature, minimum and maximums reached during each trend interval are recorded.

CBEMA Trend Logging

The IQ Analyzer can be configured to store the necessary data so that the software can display a sag or swell voltage event on the industry standard CBEMA (now ITIC) curve for predictive maintenance and troubleshooting. This application utilizes the IQ Analyzer waveform capture for high-speed events along with historical trend logging for longer term voltage disturbances. Once this data is uploaded to a PC running the Power Management Software's Event Viewer the information is analyzed, displayed and stored. Automatic uploading of CBEMA events can be selected in the software. A three-phase event will be correctly displayed as a single point on the CBEMA curve.

Event Logging

The IQ Analyzer will store in non-volatile memory the time and reason for last 504 events. These events can be viewed from the graphical display or accessed via communications. In addition to all of the meter events listed in the Event Conditions section (**Page V3-T9-56**), the following events are entered into the event log:

Time and date of:

- Alarms
- Meter power up
- All resets
- All setting changes
- Communications established or lost

Event logging is another powerful troubleshooting tool within the IQ Analyzer.

Extensive I/O and Communications Capability

One analog and three digital inputs are provided to interface with sensors and transducers. Three analog outputs and four relay contacts are furnished to share data with PLCs and control systems and to actuate alarms and control relays. Terminals are captive clamp type and finger safe. With the communications option, the device can be remotely monitored, controlled and programmed.

Ratings

- Application to 500 kV, no PTs to 600 volts
- CT ratios selectable from 5:5A to 10,000:5A
- Standard 120/600 Vac line
- Three-phase power supply module, 100–600 Vac. Separate source power supply module available, 100–240 Vac or 100–250 Vdc
- DC only separate source power module also available, 24–48 Vdc

Displayed Information Features

- All information accessible at device or through communications port via Eaton's Power Management Software
- Quality true rms readings through 50th harmonic
- Complies with the accuracy portion of ANSI C12.20 Class 0.5% revenue metering specification
- Accurate readings for nonsinusoidal waveforms with up to 3.0 crest factor
- Screens display auto ranging units, kilo units, mega units as needed
- 10-digit energy readings
- Displays multiple parameters at the same time
- Programmable custom screens

Meter Menu Screens



Meter Menu

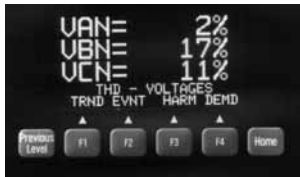

Examples of Meter Menu



Custom Screen



Custom Screen

The IQ Analyzer allows a user to view commonly used parameters by scrolling through its LED indicator Meter Menu.

Meter Menu Displayed Information

- Current
 - Phases A, B, C, average
 - Neutral
 - Ground (separate CT)
- Voltage
 - Phases A-B, B-C, C-A, average
 - Phases A-N, B-N, C-N, average
 - Neutral-ground
- Power
 - Real (watts)
 - Reactive (VARs)
 - Apparent (VA)
 - Phases A, B, C and system

- Energy (forward, reverse and net)
 - Real (kWh)
 - Reactive (kVARh)
 - Apparent (kVAh)—no reverse or net
- Frequency, time and date
- Demand
 - System current (amperes)
 - Systems real power (kW)
 - System reactive power (kVAR)
 - System apparent power (kVA)
- Power factor (Phases A, B, C and system)
 - Displacement
 - Apparent
- %THD current
 - Phases A, B, C, N
- %THD voltage
 - Phases A-B, B-C, C-A
 - Phases A-N, B-N, C-N
- K-factor
- CBEMA (ITIC) derating factor (displayed as "Z")
- Crest Factor
- Discrete input and output status
- Analog input reading
- Custom—user may program four screens to show any combination of seven Meter Menu parameters per screen

Harmonic Analysis Screens

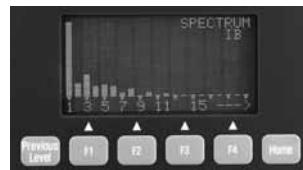

Harmonic Spectrum Available with Model 6600

Minimum and Maximum Values

- Current
 - Phases A, B, C, N, G
- Voltage
 - Phases A-B, B-C, C-A
 - Phases A-N, B-N, C-N, N-G

- Power
 - Real (Watts)
 - Reactive (VARs)
 - Apparent (VA)
 - Phases A, B, C and System
- Power factor
 - Apparent and Displacement (three-phase and system)
- Frequency
- THD (amperes, volts and %):
 - Current (Phases A, B, C, N)
 - Voltage (Phases A-B, B-C, C-A, A-N, B-N, C-N)

All minimum/maximum values may be reset via reset pushbutton on faceplate, discrete input or communications command. Values are updated at least once every 16 line cycles.

The F3 function key accesses the Harmonic Analysis screens. Two cycles of data sampled at 128 **samples/cycle** are **simultaneously** recorded for:

- Current
 - Phases A, B, C, N, G
- Voltage
 - Phases A-B, B-C, C-A
 - Phases A-N, B-N, C-N
 - Neutral to Ground

Magnitudes (or % of fundamental) of odd **and even** multiples of the fundamental from 2nd–50th are displayed. The phase angle associated with each multiple of the fundamental is also displayed.

Event/Alarm Analysis Screens



Example of Event Analysis Screens



Waveform Screen Available with Model 6600

Pressing the F2 function key accesses the Event Analysis screens. These display the following data for up to ten event/alarm conditions:

- Description, date and time of event/alarm with 10 millisecond resolution
- Current, voltages, power readings, demand readings, frequency and % THD at time of event/alarm
- Current and voltage distortion information available on Harmonic Analysis screens

Event data is stored in non-volatile memory. If a reset threshold is programmed, the *duration* of the event (e.g., undervoltage) is also displayed. With Eaton's communications option and software, waveforms and harmonic profiles may be displayed on a PC.

Event Conditions

Events may be triggered by up to seven of any of the following conditions:

Voltage Disturbances

- Undervoltage/sag—any V_{LL}, V_{LN} (40–100%)
- **Note:** 60% minimum for self-powered unit.
- Overvoltage/swell—any V_{LL}, V_{LN} (100–750%)

If zero time delay is programmed, any disturbance lasting two cycles (less if magnitude is sufficient to effect rms readings) will trigger a voltage disturbance event/alarm.

- Sub-cycle transient capture/excess dv/dt on V_{A-N} , V_{B-N} , V_{C-N}

Note: 6600 series only.

- Sub-cycle voltage interruption on V_{A-N} , V_{B-N} , V_{C-N}

Note: 6600 series only.

Maximum Threshold Exceeded

- Currents—phases A, B, C, Neutral and Ground
- Voltage—Neutral to Ground
- System Power—Watts, VA, VARs
- System Power Factor—Displacement and Apparent
- Demand
- Currents—Phase A, B, C and AVG
- System Power—Watts, VARs, VA
- Frequency
- Percent Total Harmonic Distortion or Magnitude Total Harmonic Distortion:
 - Currents—Phases A, B, C, Neutral
 - Voltage— V_{A-N} , V_{B-N} , V_{C-N} , V_{A-B} , V_{B-C} , V_{C-A}

Minimum Threshold Exceeded

- Currents—Phases A, B, C
- System Power—Watts, Vars, VA
- System Power Factor—Displacement and Apparent
- Frequency

Voltage Phase Unbalance

- Voltage L-L, L-N

Current Phase Unbalance

- Current—Phases A, B, C

Discrete Input Energized

- Input 1, 2, 3
- Remote command through communications port or front panel

All trigger conditions have programmable time delays from 0.1–60 seconds in 0.1 second increments (except Voltage Disturbances—programmable from 2–3600 cycles in two-cycle increments, and Eaton’s Power Management Software commands—no programmable delay).

Demand Recording

Peak Demands are date and time stamped for:

- Current Phases A, B, C and Average
- System Power:
 - Real (watts)
 - Reactive (VARs)
 - Apparent (VA)

Input/Output

Extensive input/output capability is standard on the IQ Analyzer. In addition to monitoring three-phase currents and voltages, separate inputs are provided for both ground and neutral currents. Voltage of neutral-to-ground is also monitored to indicate the presence of harmonics and potential downstream grounding problems. Analog and digital I/O provide interfaces for transducers, relays, PLCs and control systems.

Current Inputs

Five ampere secondary CT connections for:

- Phases A, B, C
- Ground
- Neutral
- Separate ground and neutral CT inputs
- CT range 5:5–10,000: 5 (any integer)

Voltage Inputs

- Phases A, B, C (from 120 Vac–500 kV AC)
- 120/240 Vac control power input standard—not required with optional line power module
- Separate ground-to-neutral voltage reference
- PT range 120:120–500,000:120 (any integer)

External 120-volt secondary PTs are required above 600 Vac, optional from 120–600 Vac.

Discrete Contact Inputs

Three dry contact discrete inputs may be programmed by the user to:

- Trigger Event Analysis—the information described in “Event Analysis Screens,” including Harmonic Analysis information, can be recorded when external devices trip or change state by wiring their auxiliary contacts into these inputs
- Act as a synch.-pulse input to synchronize power demand windows with utility provided synch. pulse
- Actuate a relay output
- Reset relay output, peak demands, Trend Analysis records and Event Analysis records
- With communications option, provide remote status indication on Eaton’s communication network
- Status of input contacts is displayed in the Meter Menu Custom screen

Relay Output Contacts

Four Form-C (NO/NC) relay contacts may be independently programmed to:

- Act as a kWh, kVARh or kVAh pulse initiator output
- Actuate on one or more event conditions—including discrete input software commands (through communications port)
- Reverse sequence alarm

Each relay may be set for Auto or Manual Reset with 0–30 minute release delay (one second increments). Relays are Form-C NO/NC. Relay(s) programmed to actuate on undervoltage also have a programmable 0–30 minute delay on power-up for transfer applications.

Analog Input and Outputs

One analog input and four analog outputs may be configured as 0–20 or 4–20 mA. The analog input is displayed at the device as a percentage and is accessible through the communications port. The analog input provides an interface with gas flow meters, temperature transducers or other analog devices.

The analog outputs may be programmed to reflect any of the following:

- Current—Phases A, B, C, Average, N, G
- Voltage—L-L, L-N, N-G
- Power:
 - Real (watts)
 - Reactive (VARs)
 - Apparent (VA)
 - Phases A, B, C and System
- % THD:
 - Current (Phases A, B, C, N)
 - Voltage (L-L, L-N)
- Frequency—System
- Power Factor:
 - System Displacement PF
 - System Apparent PF

Standards and Certifications

- UL listed, File E62791, NKCR File E185559 (CE versions)
- cUL listed #1010.1 C22.2
- CE mark EN61010-1 (1993) EN50082-2 (1994)
- Measurement Canada Electricity Meter AE-0782
- CSA approved



Product Selection

IQ Analyzer



IQ Analyzer

Description

Description	Catalog Number
IQ Analyzer, separate source power module	IQA6410
IQ Analyzer, 24–48 Vdc power module	IQA6420
IQ Analyzer, three-phase power module	IQA6430
IQ Analyzer, separate source power module with waveform display and sub-cycle voltage disturbance capture	IQA6610
IQ Analyzer, 24–48 Vdc power module with waveform display and sub-cycle voltage disturbance capture	IQA6620
IQ Analyzer, three-phase power module with waveform display and sub-cycle voltage disturbance capture	IQA6630
IQ Flange, to provide extra clearance when mounting	IQFLANGE
45-inch (1143.0 mm) extension cable for remote mounting of power module	IQA45CABLE
24–48 Vdc separate source power module	IQMDCPM
100–240 Vac and 100–250 Vdc separate source power module	IQMSSPM
Three-phase, self-powered power module	IQM3PPM
INCOM communication module	IPONI
RS-485 communication module with Modbus protocol	MPONI

Accessories

IQ Analyzer Auxiliary Power Supply

The optional IQ Analyzer Auxiliary Power Supply allows set point programming of the IQ meter while the monitored line power is turned off and locked out, thus eliminating the presence of dangerous line voltages. The Auxiliary Power Supply is easy to install and has been specifically designed to connect to the power supply connector on the IQ meter and then plug into a standard electrical wall outlet.

Technical Data and Specifications

IQ Analyzer 6400/6600 Series
Fuses

- Self-powered units with IQMSSPM have 3/4 ampere, 600 volts Bus Type KTK-R-3/4 fuses (three required).
- Separate source dual-voltage units with IQMSSPM have a single 5 x 20 mm 1/4 ampere fuse
- Separate source DC units with IQMDCPM do not have user replaceable fuses

Environmental Conditions

- Operating temperature: -20°-70°C
- Storage temperature: -30°-85°C
- Operating humidity: 5-95% relative humidity

Current Inputs (Each Channel)

- Conversion: true rms, 32 sample/cycle (all samples used in all rms calculations)
- CT input: 5 ampere secondary (any integer 5:5 to 10,000:5)
- Burden: 0.05 VA
- Overload withstand: 40 amperes AC continuous, 300 amperes AC 1 second
- Range: 8 x CT continuous
- Accuracy: 0.1% of CT primary rating, 0.2% of reading above 150% of rating, sinusoidal (see accuracy below for non-sinusoidal specifications)
- Input impedance: 0.002 ohm

Voltage Inputs (Each Channel)

- Conversion: True rms, 32 sample/cycle (all samples used in all rms calculations)
- PT input: direct or any integer 120:120-500,000:120
- Range: 30-660 Vac (separate source and DC source)
- Nominal full scale: 100-600 Vac
- Burden: 21 VA (self-powered only)
- Overload withstand: 635 Vac, continuous 700 Vac, 1 second
- Input impedance: 1 megohm

Frequency Range

- 20-66 Hz fundamental (up to 50th harmonic)

Harmonic Response (Voltages, Currents)

- 50th harmonic

Accuracy (in Percent Full Scale)

Accuracy from 3-300% of Full Scale and from -0.5. to 1.00 to 0.5 power factor

- Current and voltage: ±0.20%
- Power, energy and demand: 0.40%
- Frequency: 0.04%
- Power factor: 0.80%
- THD: 1.00%

Specific Current Accuracies

- ±0.20% of full scale to 200% of full scale and 150% crest factor
- ±0.20% of full scale to 150% of full scale and 200% crest factor
- ±0.20% of full scale to 100% of full scale and 300% crest factor
- ±0.40% of reading for currents to 800% of full scale
- Power and energy: Start recording with an average of 3 mA secondary current

Discrete Inputs (Dry Contact)

- +30 Vdc differential across each discrete input pair of terminals. Minimum pulse width: 1.6 msec
- Optically isolated inputs to protect IQ Analyzer circuitry

Analog Outputs (4)

- 0-20 mA/4-20 mA into maximum 750 ohm load. Accuracy: 1%

Analog Input (1)

- 0-20 mA/4-20 mA into 200 ohm load. Accuracy: 1%

Relay Output Contacts (4)

- Form C Dry Contact: 10 amperes at 120/240 Vac (Resistive) 10A at 30 Vdc (Resistive) 30A make (50 mS) at 240 Vac/240 Vdc
- Minimum pulse width: 4 cycles (68 mS)

- Withstand rating: 1000 Vac, 1 minute across contacts 5000 Vac (contacts to coil, 1 minute) 10,000 Vac (contacts to coil, surge voltage)

Relay Response Time

(Excluding programmed time delays):

- Two line cycles for Discrete Input, Eaton's software commands (communications port)
- Four to five line cycles for Voltage Disturbance, Voltage Unbalance
- Nine to 10 line cycles for all others

IQ Analyzer Auxiliary Power Supply

- Input voltage: 100-250 Vac
- Input frequency: 50/60 Hz
- Output voltage/current: +24 Vdc at 0-0.45A
- Output ripple: 100 mV maximum (peak to peak)
- Rated output power: 10.8 watts
- Turn on/turn off overshoot 5% maximum
- Turn on delay: 0.5 second maximum
- Operating temperature: 0°-40°C
- Storage temperature: -40°-80°C

Control Power Input

Description	Separate Source	Self Powered ①	DC Source
Input range, AC	110-240 Vac ±10%	110-600 Vac ±10%	N/A
Frequency range	45-66 Hz	45-66 Hz	N/A
Input range, DC	110-250 Vdc ±10%	N/A	24-48 Vdc ±20%
Burden	21 VA	21 VA	21 VA

Note

① When directly wired to 480 Vac, IQ Analyzer can ride through a continuous sag that is 20% of rated voltage.

Wiring Diagram

Field Wiring Connections—Separate Source Power Supply Shown Here (For Three-Phase Power Supply, No Separate Control Power is Required)

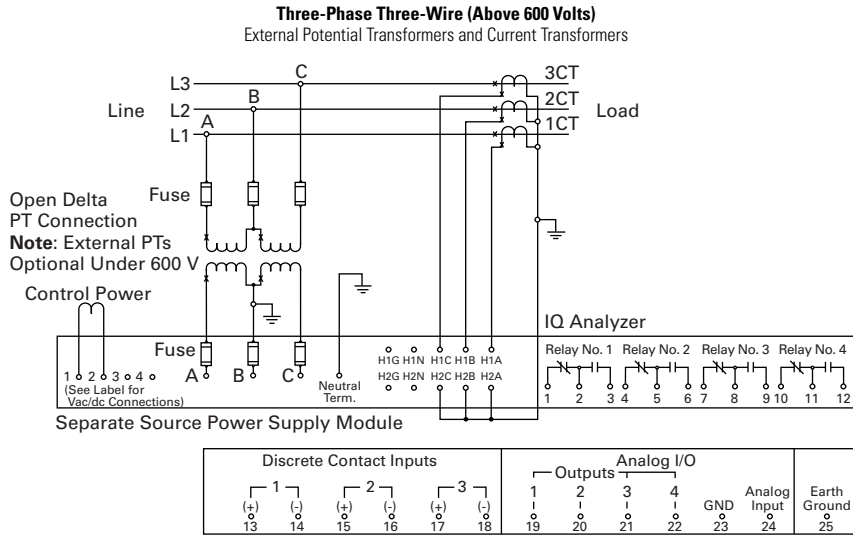

Dimensions

Approximate Dimensions in Inches (mm)

IQ Analyzer 6000 Series

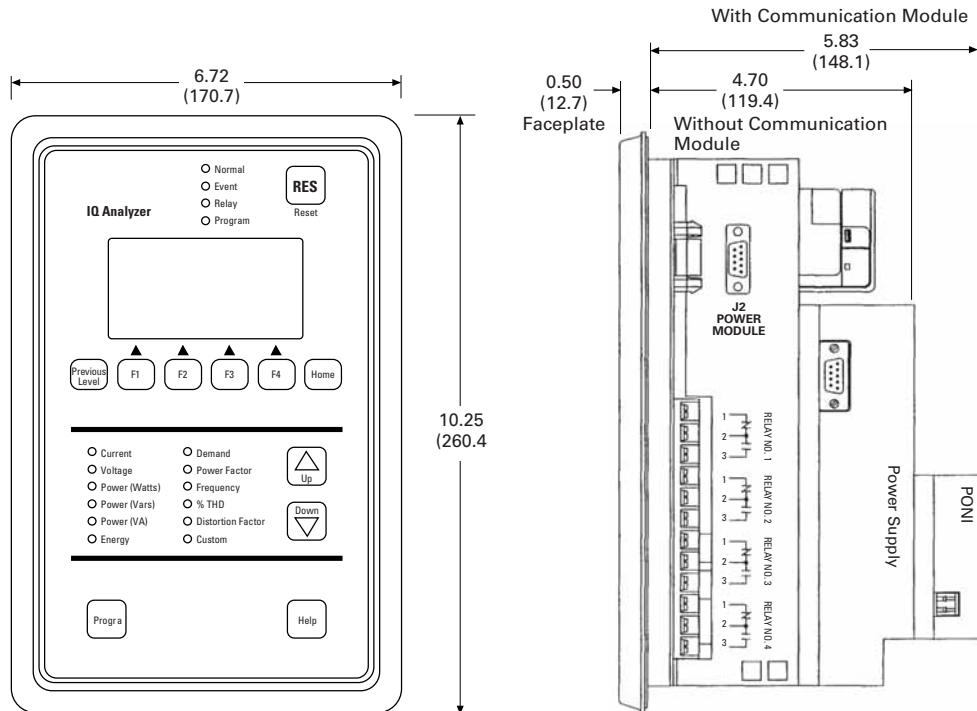

Approximate Dimensions in Inches (mm)

IQ Analyzer Auxiliary Power Supply

Width	Height	Depth	Shipping Weight Lbs (kg)
2.40 (61.0)	4.00 (101.6)	1.11 (28.2)	5.8 (3.6)

IQ Analyzer 6000 Series

Height	Width	Depth
Without PONI		
10.25 (260.4)	6.72 (170.7)	4.70 (119.4)
With PONI		
10.25 (260.4)	6.72 (170.7)	5.83 (148.1)

Drilling Pattern

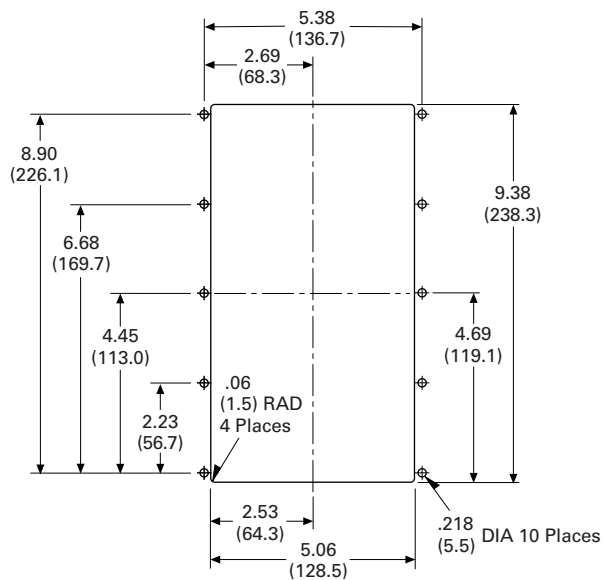

Drilling Pattern for Flange Mounting

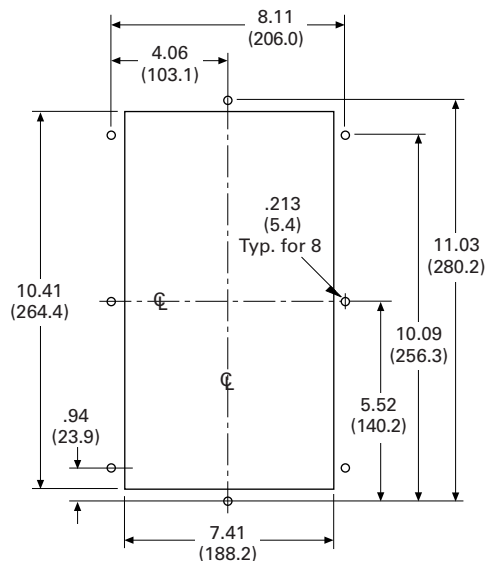

IQ DP-4000



IQ DP-4000 Series

Product Description

Eaton's IQ DP-4000 is a microprocessor-based monitoring and protective device that provides complete electrical metering and system voltage protection. In one compact, standard package, the IQ DP-4000 will provide an alternative to individually mounted and wired conventional meters and switches. The DP-4000 also monitors Apparent Power (VA), Reactive Energy (VAR-hours), Apparent Energy (VA-hours) and percent THD to provide the user with basic power quality information. The IQ DP-4000 meets and surpasses UL/CSA/CE standards.

The IQ DP-4000's rugged construction is designed to withstand harsh conditions such as temperature variations, outdoor applications and industrial environments. The membrane faceplate pushbuttons are easy to use and both the parameter LED and window displays are easily visible.

Application Description

- Monitoring of all common electrical parameters
- Optional protective alarm functions

Retrofit Opportunities

- Retrofit of existing electrical distribution systems with the IQ DP-4000 for power, quality, load and energy monitoring
- Mounting flange option for application where additional door mounting space is required; see **Page V3-T9-93**

Contents

Description

	<i>Page</i>
Metering Products Family	V3-T9-6
Power Xpert Meter 4000/6000/8000 Series	V3-T9-13
Power Xpert Meter 2000 Series	V3-T9-26
IQ 250/260 Series Electronic Power Meters	V3-T9-35
IQ 130/140/150 Series Electronic Power Meters	V3-T9-41
IQ 150S/250S Self-Enclosed Electronic Meters	V3-T9-46
IQ 35M	V3-T9-51
IQ Analyzer 6400/6600 Series	V3-T9-54
IQ DP-4000 Series	
Features, Benefits and Functions	V3-T9-63
Standards and Certifications	V3-T9-63
Product Selection	V3-T9-64
Accessories	V3-T9-64
Technical Data and Specifications	V3-T9-65
Dimensions	V3-T9-67
Power Xpert Multi-Point Meter	V3-T9-68
PM3 Monitoring and Metering Module	V3-T9-80
PM3 Monitoring and Metering Module	V3-T9-80
Current Transformers (CTs)	V3-T9-81
Clamp-On Current Transformers	V3-T9-90
IQ Flange	V3-T9-93
Panel Mounting Adapter Kit	V3-T9-94
Enclosed Meters	V3-T9-95

Features, Benefits and Functions

Historical Values

- Present demand current (per phase) 5, 10, 15, 20, 25, 30, 45 or 60 minute windows
- Present demand watts, VARs and VA 5, 10, 15, 20, 25, 30, 45 or 60 minute windows:
 - Sliding or fixed window for power Sync pulse input (Model 4100) Eaton's PowerNet broadcast demand sync
- Minimum and maximum values current (per phase):
 - Voltage (per phase, L-L, L-N)
 - Watts, VARs and VA
 - Power factor (displacement and apparent)
 - Frequency
- Peak values:
 - Percent THD parameters
 - Demand parameters

Protective and Event Alarming

- Undervoltage
- Overvoltage
- Current phase loss
- Voltage phase loss
- Phase reversal
- Phase unbalance
- Optional current and powerdemand threshold

Metered and Monitored Parameters

- rms sensing
- Phase currents
- Volts: L-L, L-N
- Power: real, reactive, apparent
- Energy: real, reactive, apparent
- Frequency
- Power factor
- % THD: current and voltage
- Minimum and maximum values
- Fixed or sliding demand windows

Communications

- Optional interface capability to computer network for data collection, storage and/or printout via Eaton's Power Management Software

Physical Characteristics

- Large visible LED display
- Membrane Faceplate NEMA 3R and 12 rated

Alarm and Protective Functions

- Alarm/Protective functions (all models) include:
 - Overvoltage
 - Undervoltage
 - Current phase loss
 - Voltage phase loss
 - Phase unbalance
 - Phase reversal
- User-programmable alarm and reset threshold levels and delay intervals
- Optional current and power demand threshold

Description of Protection Functions

Overvoltage

Range 105–140% (5% increments).

Undervoltage

Range 60–95% (5% increments).

Phase Unbalance

Deviation between any two phases percentage of nominal line voltage preset by DIP switches. Range 5–40% (5% increments).

Phase Reversal

Any two phases become reversed for the selected delay.

Voltage Phase Loss

Less than 50% of the nominal line voltage detected.

Current Phase Loss

Smallest phase current is less than 1/16 of the largest phase current.

Delay

Allows a delay before an alarm occurs. (Range 1–20 seconds in 1 second increments.)

Note: Unit must be powered for this to occur.

Inputs and Outputs (4100 Model)

- Three Form C relay outputs selectable: Trip, Alarm, kWh pulse initiator
- One synch input for kW utility demand sync

Standards and Certifications

Listings and Certifications

- UL/cUL/CSA listed
- CE mark EN61010-1, EN50082-2



Product Selection

IQ DP-4000



IQ DP-4000

Description

4 indicates an IQ DP-4000 model

x = 0 indicates no I/O; x = 1 indicates I/O

y = 1 indicates separate source supply, 110–240 Vac and 110–250 Vdc

y = 2 indicates 24–48 Vdc power supply,

y = 3 indicates three-phase power supply, 110–600 Vac

Separate source control power without I/O

Separate source control power without I/O, DC supply

Three-phase power supply without I/O

Separate source control power with three Form C relay output contacts and one sync pulse input

Separate source control power with three Form C relay output contacts and one sync pulse input, DC supply

Three-phase power supply with three Form C relay output contacts and one sync pulse input

2 Form C relay outputs for protective alarming functions, 1 Form C relay output selectable for KYZ pulse output or load shedding, 1 demand sync pulse input

IQ flange, to provide extra clearance when mounting

45-inch (1143.0 mm) extension cable for remote mounting of power module

24–48 Vdc separate source power module

100–240 Vac and 100–250 Vdc separate source power module

Three-phase, self-powered power module

INCOM communication module

RS-485 communication module with Modbus protocol

Catalog
Number

IQDP4XY0

IQDP4010

IQDP4020

IQDP4030

IQDP4110

IQDP4120

IQDP4130

DP4IOMOD

IQFLANGE

IQA45CABLE

IQMDCPM

IQMSSPM

IQM3PPM

IPONI

MPONI

Accessories

IQ DP-4000 I/O Module

For applications where field modification to add or change Input/Output (I/O) capability to the IQ DP-4000 is required, Eaton offers I/O cards. These field-installable modules can be easily inserted into an existing IQ DP-4000 where input/output application needs change.

- Power requirements: 10 VA
- Frequency: 50/60 Hz
- Operating temperature: 25°–70°C
- Operating humidity: 0–95% noncondensing
- Dry contact input: 24 Vdc differential across input pair of terminals; minimum pulse width, 50 mS

Technical Data and Specifications

Accuracy

- Maintained from 10–250% of CT primary rating

Current Inputs (Each Channel)

- Nominal full scale current: 5 amperes AC
- Current range for rated accuracy: 0–15 amperes AC
- Overload withstand: 15 amperes ac continuous 300 amperes AC 1 second
- Burden: 0.003 VA

Voltage Inputs (Each Channel)

- Voltage range (nominal): 90–600 Vac
- Nominal full scale voltage: 120–600 Vac
- Overload withstand: 660 Vac continuous 4 kV 1.2/50 μ s
- Burden: three-phase power module 10 VA

Fuses

Supplied with three-phase power module only. 3/4 ampere, 600 volt bus type KTK-R-3/4 (three required).

Contact Rating (Model 4100)

- 10 amperes at 120/240 Vac (resistive)
- 10 amperes at 30 Vdc (resistive)

Compatible with the Following Systems

- Three-phase, three-wire
- Three-phase, four-wire

Ratings

- Application to 500 kV, no PTs to 600 volts
- CT ratios selectable from 5:5 A to 12800: 5A
- Standard 120/600 Vac line three-phase power supply module. Two separate source power supply modules available. One module from 110– 240 Vac and 110–250 Vdc; the other module 24–48 Vdc only

Model 4100 Input and Output

Model	Input	Output
4000	0	0
4100	1 digital (dry contact)	3 relays

Control Power Input

Description	Separate Source	Self Powered	DC Source
Input range, AC	110–240 Vac \pm 10%	110–600 Vac \pm 10%	N/A
Frequency range	45–66 Hz	45–66 Hz	N/A
Input range, DC	110–250 Vac \pm 10%	N/A	24–48 Vdc \pm 20%
Burden	10 VA	10 VA	10 VA

Displayed Values

Description	Displayed Through Eaton's PowerNet System	Local Display
AC amperes, phases A, B, C	\pm 0.3%	\pm 0.3% \pm 1 digit
AC voltage, phase A-B, B-C, C-A	\pm 0.3%	\pm 0.3% \pm 1 digit
Phase A-N, B-N, C-N	\pm 0.3%	\pm 0.3% \pm 1 digit
Watts	\pm 0.6%	\pm 0.6% \pm 1 digit
Vars	\pm 0.6%	\pm 0.6% \pm 1 digit
VA	\pm 0.6%	\pm 0.6% \pm 1 digit
Watt-hours	\pm 0.6%	\pm 0.6% \pm 1 digit
VAR-hours	\pm 0.6%	\pm 0.6% \pm 1 digit
VA-hours	\pm 0.6%	\pm 0.6% \pm 1 digit
Power factor	\pm 1%	\pm 1%
Frequency	\pm 0.1 Hz	\pm 0.1 Hz
% THD	Through 31st harmonic	Through 31st harmonic

Note

All accuracy is measured as a percentage of full scale.

Wiring Diagrams

Field Wiring Connections

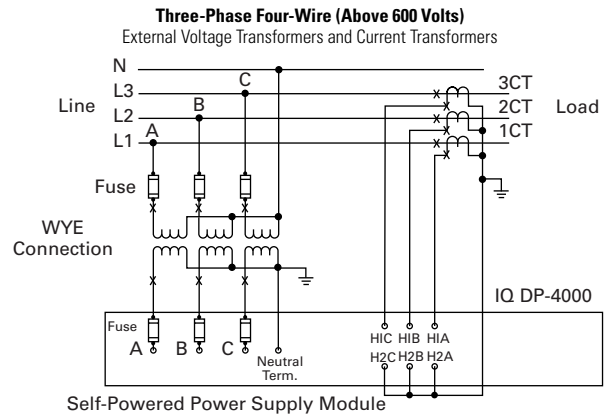
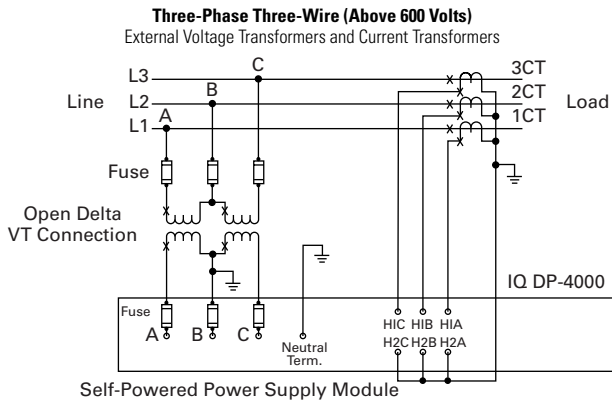
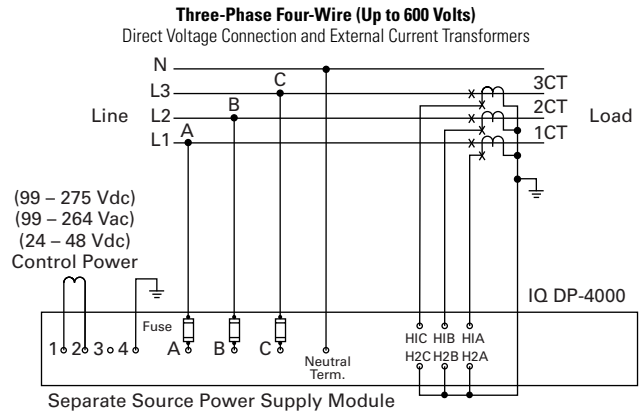
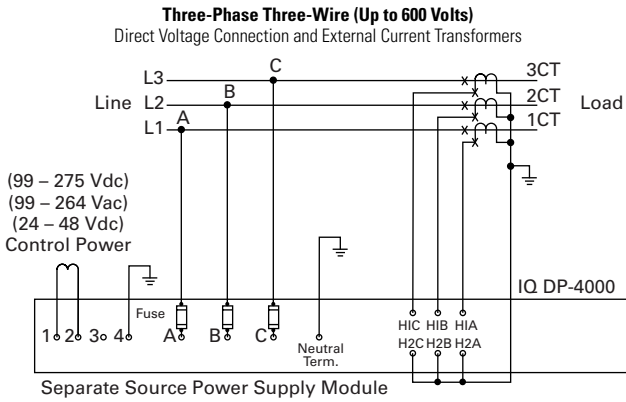

Dimensions

Approximate Dimensions in Inches (mm)

Drilling Pattern

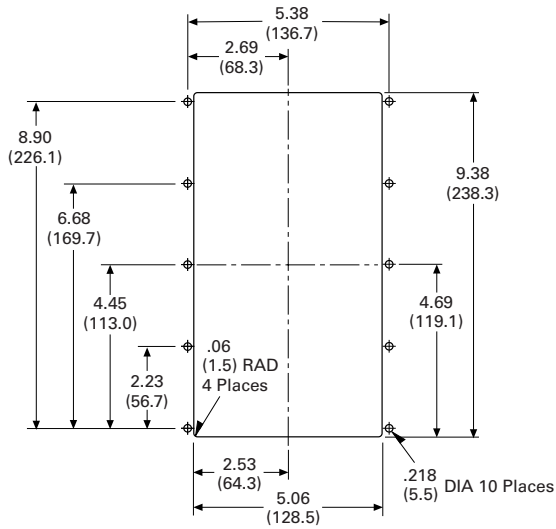

IQ DP-4000 Side View

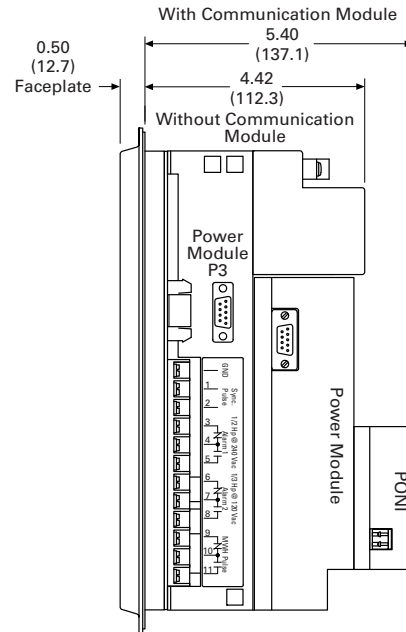

LED Display

Height	Width	Depth	Shipping Weight Lbs (kg)
PONI			
10.25 (260.4)	6.72 (170.7)	5.40 (137.2)	6.50 (3.0)
Without PONI			
9.02 (229.0)	7.80 (198.1)	4.42 (112.3)	12.5 (5.7)

IQ DP-4000 Auxiliary Power Supply

Width	Height	Depth
2.40 (61.0)	4.00 (101.6)	1.11 (28.2)

Power Xpert Multi-Point Meter



Power Xpert Multi-Point Meter

Product Overview

Eaton's Power Xpert™ Multi-Point Meter is an ANSI C12.20 revenue class Web-enabled electronic submetering device that can be mounted in panelboards, switchboards or enclosures. When mounted in a panelboard or a switchboard, the Power Xpert Multi-Point Meter provides customers with an integrated power distribution and energy metering solution that saves space, reduces installation labor and lowers total cost.

The Eaton Power Xpert Multi-Point Meter (PXMP Meter) offers a highly modular approach to high-density metering applications in electrical power distribution systems. The PXMP Meter is compatible with most three-phase industrial, commercial and single-phase residential low voltage electrical power systems. The PXMP is equipped with two Modbus® RTU communication ports for local display and remote serial communications. The PXMP also has optional pulse input and digital output modules along with one standard digital output and three digital inputs. The PXMP Energy Portal Module is Web enabled, making it suitable for use with Ethernet networks and modems.

Contents

<i>Description</i>	<i>Page</i>
Metering Products Family	V3-T9-6
Power Xpert Meter 4000/6000/8000 Series	V3-T9-13
Power Xpert Meter 2000 Series	V3-T9-26
IQ 250/260 Series Electronic Power Meters	V3-T9-35
IQ 130/140/150 Series Electronic Power Meters	V3-T9-41
IQ 150S/250S Self-Enclosed Electronic Meters	V3-T9-46
IQ 35M	V3-T9-51
IQ Analyzer 6400/6600 Series	V3-T9-54
IQ DP-4000 Series	V3-T9-62
Power Xpert Multi-Point Meter	V3-T9-68
PM3 Monitoring and Metering Module	V3-T9-80
Current Transformers (CTs)	V3-T9-81
Clamp-On Current Transformers	V3-T9-90
IQ Flange	V3-T9-93
Panel Mounting Adapter Kit	V3-T9-94
Enclosed Meters	V3-T9-95

Product Description

The Power Xpert Multi-Point Meter can measure up to any of the following number of circuits:

- Sixty single-phase, two-wire (single-pole)
- Thirty single-phase, three-wire (two-pole)
- Twenty three-phase, four-wire (three-pole)

The circuits listed above can be mixed provided that the total number of current sensors does not exceed 60. The meter provides current; voltage; power factor; demand and active, reactive, and real power (VA, VAR, kW); and active, reactive, and real energy (VA, VAR, kWh) measurements for each load. The unit also provides up to two years at 15-minute intervals or eight years at one-hour intervals of demand data logging storage in non-volatile memory for up to 60 submeters.

The Power Xpert Multi-Point Meter can be used with three different ratings of current sensors: 100 mA, 10 mA or 333 mV. Switchboard/panelboard applications will use the 100 mA current sensors, which are highly accurate, self-protecting in the event of an open circuit condition under load and are supplied with an integral plug-in connector. The PXMP automatically detects the rating of the current sensor that is connected.

The PXMP can also use 10 mA current sensors that were previously installed for IQMESII retrofit applications. Additionally, the PXMP can use 333 mV split core current sensors for retrofit applications where metering has not previously existed. The 10 mA and 333 mV current sensors are also self-protecting in the event of an open circuit condition under load.

Application Description

The Power Xpert Multi-Point Meter is ideally suited to handle submetering in low voltage power distribution equipment applications such as distribution boards in multi-tenant buildings, comprehensive main and feeder metering in commercial/industrial switchboards or medium voltage distribution equipment with the use of voltage and current transformers.

The Power Xpert Multi-Point Meter provides a cost-effective solution for residential or commercial metering installations. Typical installations include:

- High-rise buildings
- Government institutions
- K-12, universities and campuses
- Office buildings
- Medical facilities
- Apartment and condominium complexes
- Airports
- Shopping malls
- Industrial sites
- Mixed-use facilities

Features

- Monitors power and energy for up to 60 current sensors; space-saving modular design allows measurement from 1 to 60 circuits
- Built-in communication interfaces
- Monitors single-phase and three-phase loads from 120 to 600 Vac
- Monitors current, voltage, power factor, frequency, power and energy
- Stores extensive energy profile data for each metering point; can be used to identify coincidental peak demand contribution
- LEDs provide status of unit communication activity and verify sensor connections
- Meets rigid ANSI C12.20 accuracy specifications for revenue meters
- Three standard digital inputs and eight pulse inputs per optional module to monitor WAGES (water, air, gas, electric, or steam)
- One standard digital output and eight digital outputs per optional module for alarm indication
- Three types of meter modules to support 10 mA, 100 mA or 333 mV sensors

- Can be directly mounted in a UL Listed panelboard, switchboard or enclosure
- 256 MB of memory in meter base for up to two years of 15-minute interval data (eight years of one-hour interval data) for eight demand values up to 60 submeters

Communication Capabilities

With the Power Xpert Multi-Point Meter’s built-in communication capabilities, remote meter reading and monitoring functions can be integrated into both new and retrofit applications.

- Standard Modbus RTU
- Optional Modbus TCP / BACnet/IP / SNMP / HTTP / SMTP / NTP /SFTP communications

Software Compatibility

The Power Xpert Multi-Point Meter:

- Can be used as part of an electrical energy monitoring and cost allocation system
- Can be remotely monitored via onboard Web pages with Eaton’s optional Energy Portal Module
- Is compatible with third-party software platforms and interface devices

Configuration

- The Power Xpert Multi-Point Meter is fully configurable using Power Xpert Multi-Point configuration software that can be down-loaded free from the Eaton website at www.eaton.com/meters
- Each Power Xpert Multi-Point Meter module can be configured for up to six metering points in any combination of single-phase and three-phase metering points corresponding to the voltage wiring of the meter base
- Power Xpert Multi-Point configuration software simplifies system commissioning and startup; PXMP configuration software supports both online and offline configurations

Easy to Install

- UL Listed for mounting inside panelboards (e.g., PRL4), switchboards, and NEMA 12 enclosures
- Quick connect terminals for current sensors, Modbus communications, and bus voltages make wiring the unit quick and easy

Features

Description	Main/Aggregate	Channel Data	Tenant
Instrumentation			
Current, per phase	■ ①	■	—
Voltage, per phase (L-L, L-N)	■	■	—
Frequency	—	■	■
Minimum/maximum readings, V	Per phase	—	—
Minimum/maximum readings, W, VAR, VA	Total and per phase	—	—
Minimum/maximum readings, PF, F	Total	—	—
Power			
Real, reactive, and apparent power (W, VAR, VA)	Total and per phase	Total and per phase	Total
Power factor	—	Average	Average
Demand			
Block interval (fixed, sliding)	■	—	—
Real, reactive and apparent power demand	Total and per phase	—	—
Minimum/maximum readings, PF, W, VAR, VA	Total and per phase	Total	—
Energy			
Real, reactive and apparent energy (Wh, VARh, VAh)	Total	—	Total
Real, forward and reverse, and total (Wh)	■	—	■

Note

① Main only.

Standards and Certifications

Environmental

The PXMP Meter and current sensors must be housed in a NEMA or UL enclosure that keeps the internal environment within the PXMP's environmental specification ranges and provides suitable fire and mechanical protection in the end product installation.

- Temperature range: –20 to +70°C (–4 to +158°F)
- Storage temperature range: –40 to 85°C
- Humidity: 5–95% noncondensing environment
- Pollution degree: II
- Elevation: 0 to 9843 ft (0 to 3000m)
- Housing: IP20
- CE Mark
- EMC EN61326

Emissions Conducted and Radiated

- FCC part 15 Class B
- CISPR 11 Class B

Electromagnetic Immunity

Standard	Description	Level
EN61000-4-2	ESD	3
EN61000-4-3	RF radiated	3
EN61000-4-4	Electrical fast transient	3
EN61000-4-5	Surge	3 ①
EN61000-4-6	RF conducted	3
EN61000-4-11	Volt sag/swell/variation	—

Product Safety

- IEC/EN61010-1
- UL 61010-1 File E185559
- CNL evaluation to CAN/C22.2 No 1010.1.92

Accuracy

- ANSI C12.20—Accuracy Class 0.5% with either CSXXX or PXMP-CSXXX sensors
 - Measurement Canada Approval Pending



Product Selection

The Power Xpert Multi-Point Meter, current sensors, and other accessories can be ordered from Eaton distributors. Refer to the following catalog numbers when ordering.

Power Xpert Multi-Point Meter Products

Product Description	Catalog Number
Meter Bases and Meter Modules with ABCN Voltage Inputs	
PXMP meter base—three-phase with ABCN voltage inputs	PXMP-MB
PXMP meter module with six 100 mA inputs for use with PXMP current sensors	PXMP-MM100MA
PXMP meter module with six 10 mA inputs for use with IQMESII current sensors	PXMP-MM10MA
PXMP meter module with six 333 mV inputs for use with 333 mV current sensors	PXMP-MM333MV
Meter Bases and Meter Modules with ABN Voltage Inputs	
PXMP meter base—single-phase, three-wire with ABN voltage inputs	PXMP-MB-AB
PXMP meter module with six 100 mA inputs for use with PXMP current sensors	PXMP-MM100MA-AB
PXMP meter module with six 10 mA inputs for use with IQMESII current sensors	PXMP-MM10MA-AB
PXMP meter module with six 333 mV inputs for use with 333 mV current sensors	PXMP-MM333MV-AB
IO Modules	
PXMP meter pulse input module with eight inputs	PXMP-PIM
PXMP meter digital output module with eight outputs	PXMP-DOM
Communication Module	
PXMP meter energy portal module	PXMP-EPM
Current Sensor Kits	
KIT, PXMP CS125 sensor, quantity of 3	PXMP-CS125-3
KIT, PXMP CS250 sensor, quantity of 3	PXMP-CS250-3
KIT, PXMP CS400 sensor, quantity of 3	PXMP-CS400-3
Current Sensor Cable Kits	
KIT, PXMP sensor cable, 4 ft (1.2m), quantity of 3	PXMP-SC4-3
KIT, PXMP sensor cable, 6 ft (1.8m), quantity of 3	PXMP-SC6-3
KIT, PXMP sensor cable, 8 ft (2.4m), quantity of 3	PXMP-SC8-3
KIT, PXMP sensor cable, 12 ft (3.7m), quantity of 3	PXMP-SC12-3
Current Sensor Extension Cable Kits	
KIT, PXMP sensor extension cable, 8 ft (2.4m), quantity of 3	PXMP-SCE-8-3
KIT, PXMP sensor extension cable, 16 ft (4.9m), quantity of 3	PXMP-SCE-16-3
Interface Modules	
PXMP current sensor interface module for 333 mV, kit X 3	PXMP-IM333MV-3

Note

Total sensor lead length must not exceed 28 ft (8.5m).

The Pulse Input Module (PXMP-PIM) can be used to totalize pulse outputs from water meters, gas meters, steam meters or even old electrical meters with KZ pulse outputs. The PXMP-PIM can also be used for status monitoring in applications where status indication updates of 6 seconds over Modbus satisfies the application requirement.

Support products for the Power Xpert Multi-Point Meter include the HMI display, IMPCABLE and power supplies as described in the table below.

Power Xpert Multi-Point Meter Support Products

Product Description	Catalog Number
Communication cable, 1000 ft (305m), 600V insulation	IMPCABLE
PXMP meter display—6-inch color touchscreen (with cable)	PXMP-DISP-6
Power supply—single-phase 90–264 Vac, 24 Vdc at 2.5A	PSG60E
Power supply—three-phase 360–575 Vac, 24 Vdc at 2.5A	PSG60F
Power supply—three-phase 600 Vac, 24 Vdc	PSS55D

Meter Selection

Meter Module	Meter Base		Typical Applications			
	Three-Phase Application or Single-Phase with ABCN	Single-Phase Application with ABN	New Switchboards PXMP Current Sensors, Solid Core, PXMP-CSXXX, Ampere Ratings	Retrofit Existing IQMESII Sensors, Solid Core, CS-XXX, Ampere Ratings	Enclosed PXMP 333MV Sensors, Split Core, CS-SP-X-XXXX-333MV, Ampere Ratings	Enclosed PXMP Interface Modules
PXMP-MM100MA	PXMP-MB	—	125, 250, 400	—	—	—
PXMP-MM333MV	PXMP-MB	—	—	—	100, 200, 300, 400, 600, 800, 1000, 1200, 1600, 2000 ^①	PXMP-IM333MV
PXMP-MM10MA	PXMP-MB	—	—	5, 50, 70, 125, 200, 400	—	—
PXMP-MM100MA-AB	—	PXMP-MB-AB	125, 250, 400	—	—	—
PXMP-MM333MV-AB	—	PXMP-MB-AB	—	—	100, 200, 300, 400, 600, 800, 1000, 1200, 1600, 2000 ^①	PXMP-IM333MV
PXMP-MM10MA-AB	—	PXMP-MB-AB	—	5, 50, 70, 125, 200, 400	—	—

Note

^① For applications requiring more than 2000A current sensors, use a CS005 with 5A CT in conjunction with PXMP-MM10MA.

Technical data and Specifications

External Circuit Group Specifications

PXMP-MB (-AB) Meter base

Discrete Output

- Quantity 1—solid-state relay Form A NO Bidirectional FET
- Polarity of external source is not important
- Isolation circuit to ground 2 kV/1 min.
- Maximum external source voltage 28 Vdc
- Line-to-line TVS clamp across switching element at 32 Vdc
- Solid-state relay on resistance 35 ohms maximum
- Maximum load current 80 mA
- Minimum pulse width 20 milliseconds
- Fixed 25 milliseconds for pulse initiator function
- Maximum pulse rate 25 Hz
- Wiring to two-position removable terminal plug
 - 12–18 AWG (3.31–0.82 mm²), wire ferrules recommended
 - T1 (polarity not important)
 - T2 (polarity not important)

Discrete Inputs

- Quantity 3, common circuits inputs 1–3
- Group isolation 2 kV
 - No input-to-input circuit isolation
- All inputs per module share a common external 24V (±10%) supply
 - 24V externally sourced between common and inputs
 - Design to interface with external dry contact
 - Input impedance ~2.2K ohms
 - Input current draw ~10 mA per input
- Minimum pulse width 10 milliseconds
- Maximum pulse rate 20 Hz
- Wiring to four-position removable terminal plug
 - 12–18 AWG (3.31–0.82 mm²), wire ferrules recommended
 - T3—Common (connect ext. 24 common here)
 - T4—Input 1 (dry contact to 24V hot)
 - T5—Input 2 (dry contact to 24V hot)
 - T6—Input 3 (dry contact to 24V hot)

COM1 and COM2 RS-485 Serial Ports

- No D+/D– biasing reliance on fail-safe driver and biasing at Master
- Baud rate configurable between 9600–115K baud (default)
- Use cable designed for RS-485 communications
 - Low L:L capacitance
 - Impedance of ~100–120 ohms
 - Shield—Mylar for high frequency; Braid for low frequency
 - Separate common and shield for best noise immunity
 - Maximum cable length is 4000 ft (1219.2m) with 32 nodes at 19.2K baud increased data rates will reduce maximum cable distance
 - 2000 ft (609.6m) with 32 total nodes at 115.2K baud
- Isolation 300V to ground due to TVS diode clamps
- Modbus RTU slave protocol, address defined by rotary switch
- Green Rx and Red Tx LEDs per channel
- Data + > Data—during idle marked, logic 1 state

- End of Line Termination resistance should match cable impedance (typ. 100–120 ohms)
- Four-position removable terminal plug 18–22 AWG (0.82–0.33 mm²) typical, wire ferrules recommended
 - COM1
 - T7—Shield
 - T8—RS-485 common
 - T9—Data –
 - T10—Data +
 - COM2
 - T11—Shield
 - T12—RS-485 common
 - T13—Data –
 - T14—Data +

PXMP-MB Power Supply Input

- 24 Vdc ±20%
- 15W maximum load
- 1 kV isolation barrier internal to PXMP-MB
- Externally fuse circuit to protect wire
- Green power OK LED
- Three-position terminal block 16–12 AWG (1.31–3.31 mm²), wire ferrules recommended
 - T15—24 Vdc – (common)
 - T16—24 Vdc + (Hot)
 - T17—Shield (optional) capacitively referenced to chassis ground for enhanced EMC performance

Meter Voltage Inputs

- Overvoltage CAT III
- Maximum voltage rating
 - 480VL:G (corner grounded delta)
 - 347VL:N
 - 600VL:L
- Frequency rating 47–63 Hz
- Metering range (temporary transitions)
 - 30–700VL:N
 - 30–700VL:L
- Abuse withstand rating 1000V sustained
- High pot withstand rating 2500V/1min
- Input impedance 4M ohms
- Fuse inputs rated to protect wiring to mains. External fuses
 - must be installed between the meter voltage terminal and the mains disconnect switch to the main lines to protect the lines. 600V 1 A BUSS type KTK-R-1 Fast Acting or equivalent fuses
 - are recommended.
- Wiring to removable terminal plug 10–18 AWG (5.26–0.82 mm²), wire ferrules recommended
 - T18—N (VR)
 - T19—C (V3)
 - T20—B (V2)
 - T21—A (V1)

PXMP meter modules (PXMP-MMs)

Compatible with all PXMP Meter Base slots 1–10 LED indicators:

- Health and status green, blink to show activity
- Pulse energy output one red per group of three loads
- Load energy direction red/green pair per load

All variations support six load inputs.

Current sensor connection is one 2 x 2 connector per load.

Compatible with PXMP-SCXX sensor cables, total cable length to the sensor should not exceed 28 ft (8.5m).

Note that -AB suffix only affects what voltage channels the loads are paired with for metering purposes.

PXMP-MM10MA supports the CSXXX series of 10 mA maximum secondary output current transformers.

PXMP-MM100MA supports the PXMP-CSXXX series of 100 mA maximum secondary output current transformers.

PXMP-MM333MV supports 333 mV maximum secondary output current transformers with the use of the PXMP-IM333MV interface module.

PXMP digital output module (PXMP-DOM)

- Compatible with all PXMP-MB slots 1–10
- LED indicators
 - Health and status green, blink to show activity
 - Output On/Off status one green per output
 - Eight individual solid-state relay outputs
- Each circuit rated for 24 Vdc ($\pm 20\%$) with an 80 mA load maximum
- 24 Vdc is externally sourced
- Group isolation to ground 2 kV
- Each circuit has its own separate common, circuit-to-circuit isolation 120V
- 16-position removable terminal plug
- 12–18 AWG (3.31–0.82 mm²), wire ferrules recommended

PXMP pulse input modules (PXMP-PIMs)

- Compatible with all PXMP-MB slots 1–10
- LED indicators
 - Health and status green, blink to show activity
 - Input On/Off status one green per pulse input
- Eight pulse inputs to external dry contacts
- Maximum pulse rate is 20 Hz
- Minimum pulse width is 20 milliseconds
- External circuit groups rated for 24 Vdc ($\pm 20\%$)
 - All circuits share the same electrical common
- External supply connects to the module with a two-position removable terminal plug
- The supply is internally fanned out to all circuits
- Group isolation limited to 300V to ground due to TVS diode clamp
- Input impedance $\sim 2.2K$ causing a 10 mA load per input when energized
- External circuit groups connect with a 16-position removable terminal plug
 - Terminals support 12–18 AWG (3.31–0.82 mm²), wire ferrules recommended

PXMP energy portal module (PXMP-EPM)

- Only functionally compatible with PXMP-MB slot 10
- LED indicators
 - Top health and status green, blink to show activity
 - Com. reset button—reset to defaults
 - Local IP 192/10
 - RJ45 front-facing Ethernet configuration port LEDs
 - Link (Tx/Rx blink)
 - 10/100 speed
- LED four-stack for bottom LAN/WAN Ethernet port
 - Link (Tx/Rx blink)
 - 10/100 speed
 - DHCP/Fixed
 - TX active
- Config. Ethernet RJ45 Cat5 STP/UTP
 - 10Base-T/100Base-Tx
 - Auto crossover capability supported
 - Java Web browser interface
- Bottom facing LAN/WAN Ethernet port
 - RJ45 Cat5 STP/UTP 10Base-T/100Base-Tx
 - STP required for full electromagnetic immunity
 - Auto crossover capability supported
 - Supports Modbus TCP and Java Web browser interface
- Bottom-facing telephone modem interface
 - Modem type V92/56K baud
 - RJ11 field interface

Power Xpert Multi-Point Meter System—Hardware Specifications

Components	Field Circuit	Power Source	Rated Voltage	Rated Current	Circuit Impedance	Isolation	Note 1	Note 2
PXMP-MB PXMP-MB-AB	Digital output	External	24 ±20% ①	0.080A maximum	35 ohms maximum	2.0 kV	—	—
	Digital input	External	24 ±20% ①	0.01A	2.22K	2.0 kV	Opto drops supply by 2V	Group are electrically common
	COM1 RS-485	Internal	5V ①	—	50–60 ohms	300V	TVS diode clamped to PE	—
	COM2 RS-485	Internal	5V ①	—	50–60 ohms	300V	TVS diode clamped to PE	—
	Power supply input	External	24 ±20% ①	0.7A maximum	N/A	1.0 kV	Installation Class II input	15W maximum
	Voltage inputs A (V1)/ B (V2)/ C (V3)/ N (VR)	External mains	480V L:G ②	0.12 mA	4M ohms	N/A	Installation Class III	High pot 2500V/1 minimum
347V L:N ②			0.09 mA	4M ohms	N/A	Installation Class III	High pot 2500V/1 minimum	
600V L:L ②			0.09 mA	4M ohms	N/A	Installation Class III	High pot 2500V/1 minimum	
PXMP-MM100MA	CT secondary	External	N/A	100 mA	14.6 ohms	N/A	20% over-range	See sensor for primary isolation
PXMP-MM10MA	CT secondary	External	N/A	10 mA	67 ohms	N/A	20% over-range	See sensor for primary isolation
PXMP-MM333MV	CT secondary	External	0.333V ②	N/A	50,000 ohms	N/A	20% over-range	See sensor for primary isolation
PXMP-DOM	Digital output	External	24 ±20% ①	0.080A maximum	10 ohms maximum	2 kV group	120V isolation circuit-to-circuit	Isolation dependent on external source
PXMP-PIM	Pulse input	External	24 ±20% ①	0.01A	2.22K ohms	300V to ground	TVS diode clamped to PE; group isolated, all circuits common to 24V external source	Note: Opto creates 2.2V drop sourced by 2.2K ohms; isolation dependent on external source
PXMP-EPM	Ethernet 100 Bt	Internal	—	N/A	N/A	1 kV	—	—
	POT modem	Internal	—	N/A	N/A	—	—	—

Notes

- ① DC.
② AC RMS.

Wiring Diagrams

Wiring for PXMB-MB

Note: For all voltage connections—fuses should be sized in accordance with best practices to protect the instrumentation wire.

Four-Wire Wye Voltage Connection Inputs

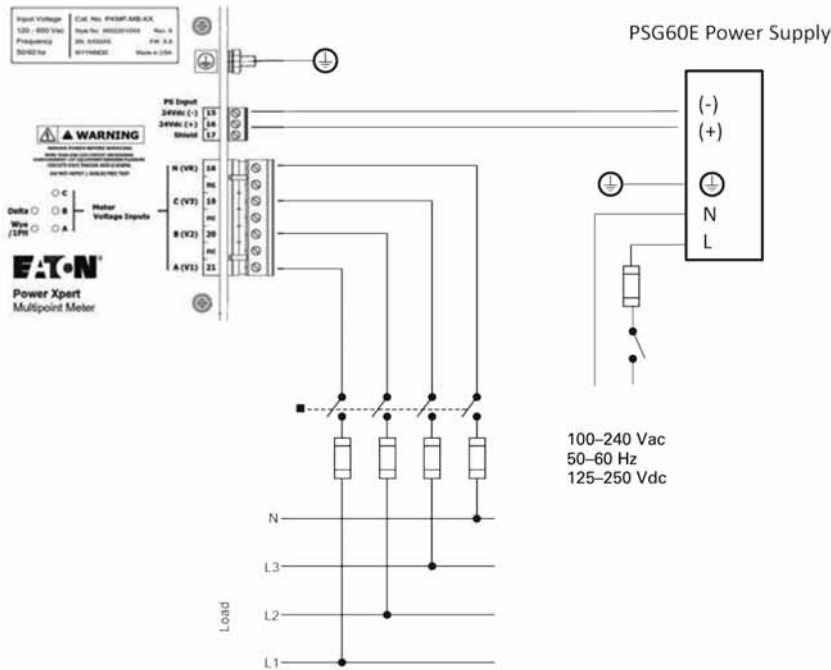

Three-Phase, Four-Wire Service Current Sensor Connections

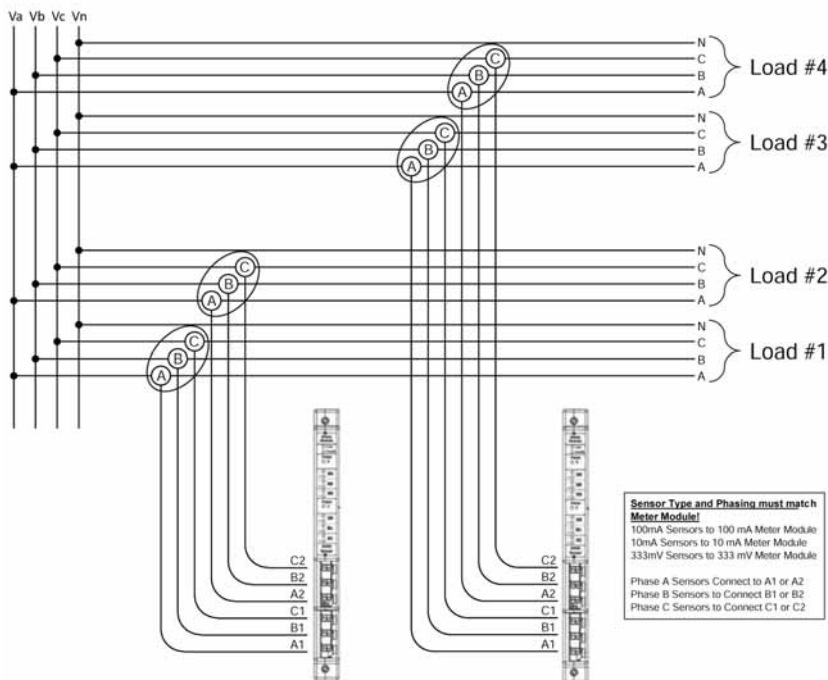

Three-Phase, Four-Wire Service (Ten Single-Phase, Single-Pole) Current Sensor Connections

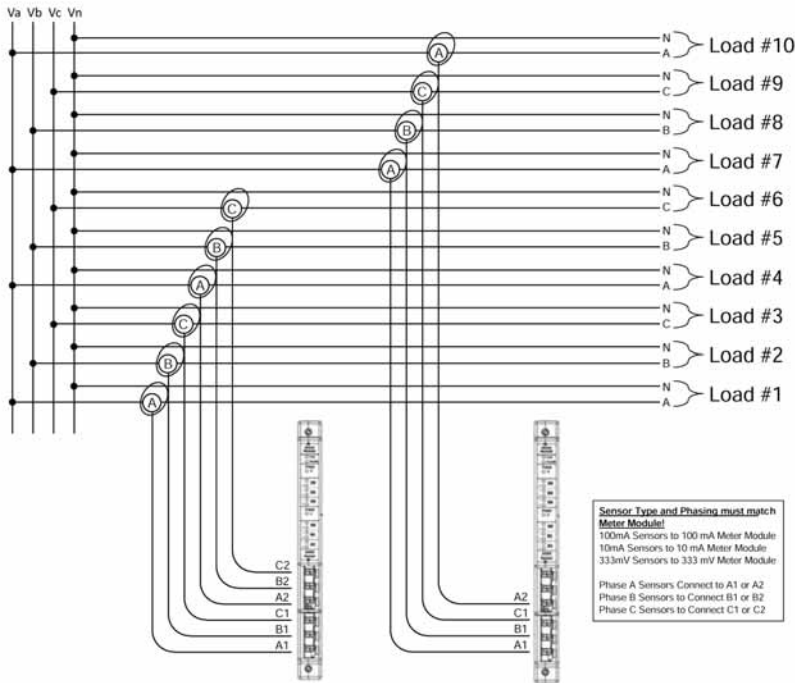

9

Network 120/208 Three-Wire Apartment Service Current Sensor Connections

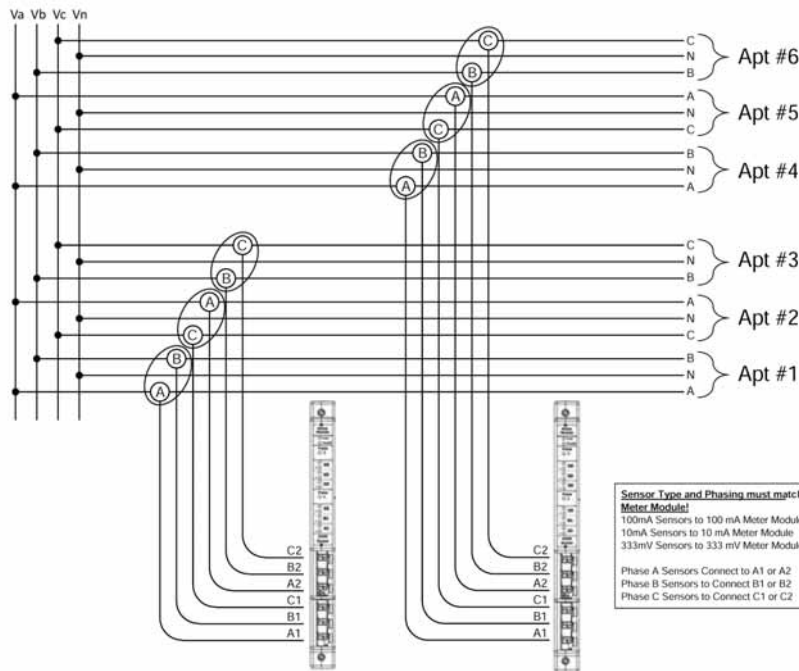

Wiring for PXMB-MB-AB

Note: For all voltage connections—fuses should be sized in accordance with best practices to protect the instrumentation wire.

Single-Phase, Three-Wire 120/240 Voltage Connection Inputs

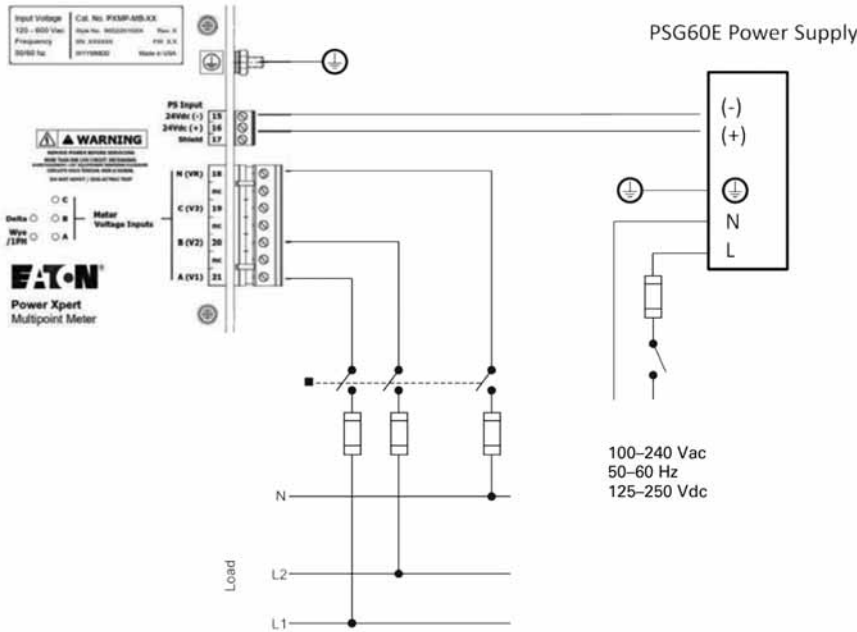

120/240 Single-Phase, Three-Wire Service Current Sensor Connections

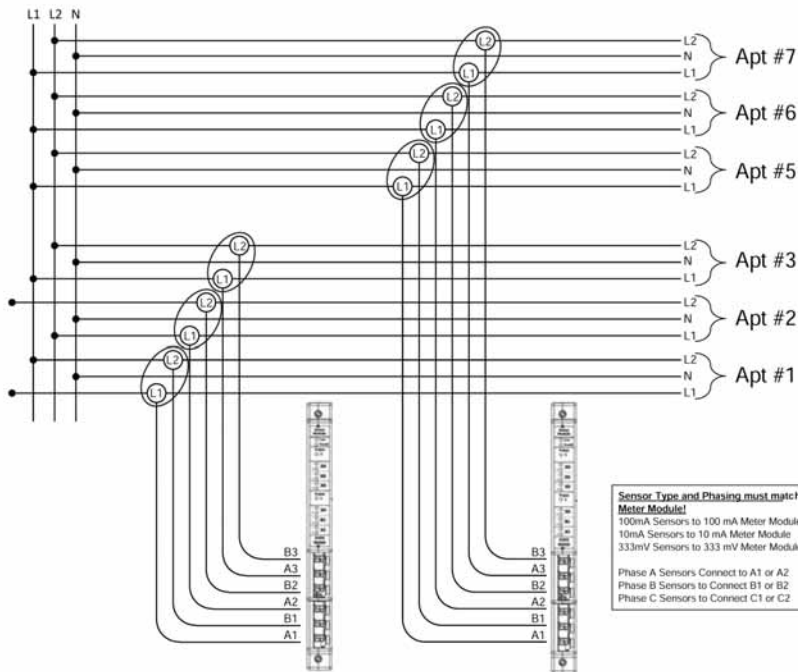

9.2

Metering Devices, Protective Relays, Software and Connectivity

Metering Devices

Dimensions

Approximate Dimensions in Inches (mm)

Single Unit—Front View

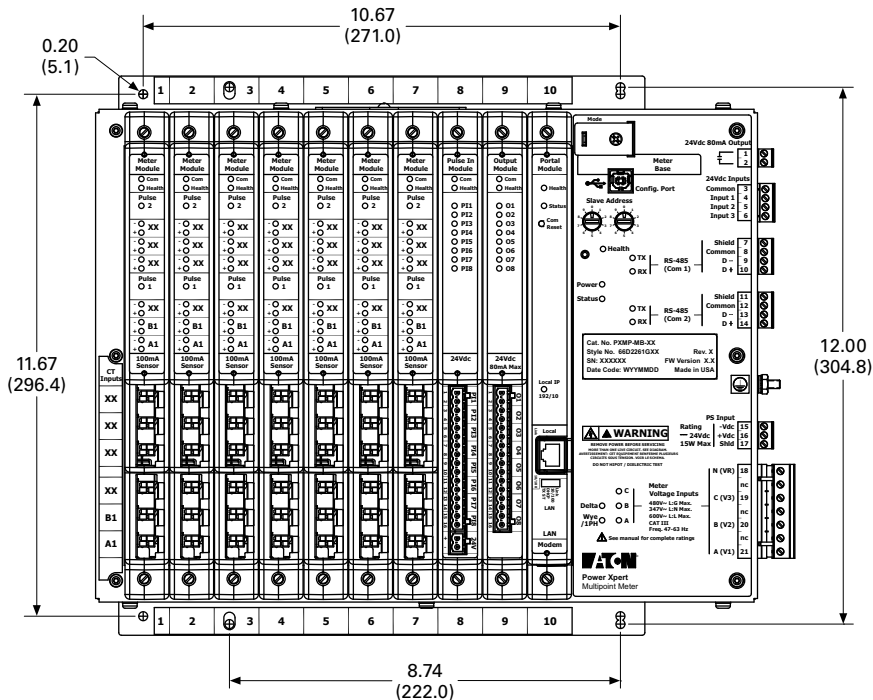

Single Unit—Side View

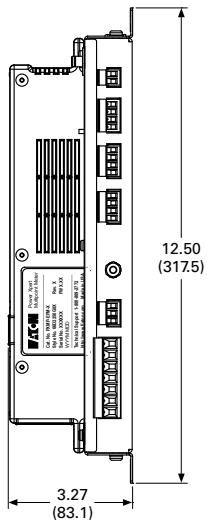

Current Sensor Dimensions

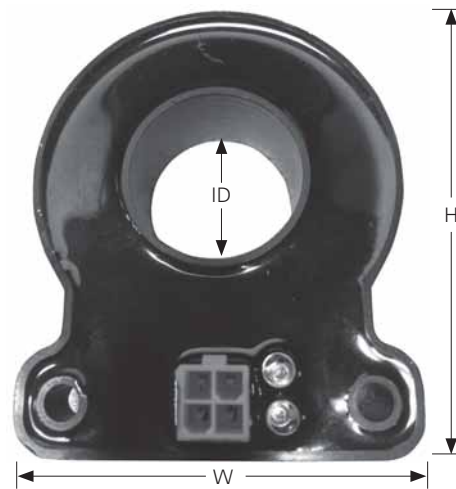

Single Unit—Top View

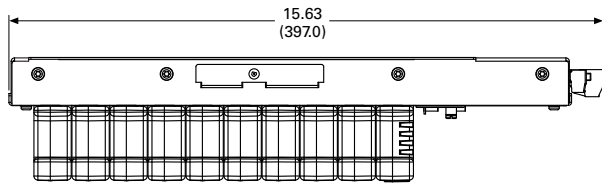

Current Sensor Dimensions

Sensor	H	W	D
PXMP-CS125	2.66 (67.6)	1.66 (42.1)	0.53 (13.5)
PXMP-CS250	2.96 (75.2)	2.42 (61.5)	1.12 (28.4)
PXMP-CS400	3.64 (92.5)	3.03 (73.2)	1.74 (44.2)

PXMP Color Touchscreen Display

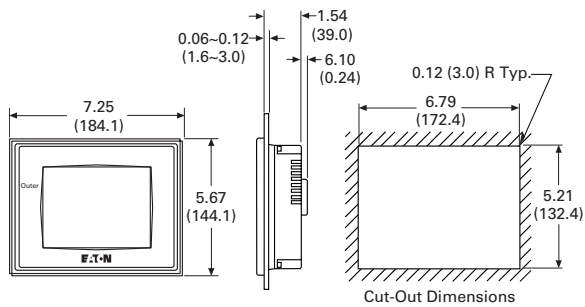

Open Interface Module (PXMP-IM333MV)

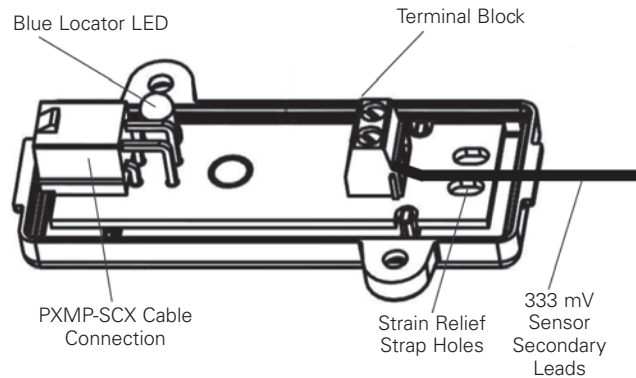

PM3 Modules



Power Monitoring and Metering with Modbus RTU

Contents

<i>Description</i>	<i>Page</i>
Metering Products Family	V3-T9-6
Power Xpert Meter 4000/6000/8000 Series	V3-T9-13
Power Xpert Meter 2000 Series	V3-T9-26
IQ 250/260 Series Electronic Power Meters	V3-T9-35
IQ 130/140/150 Series Electronic Power Meters	V3-T9-41
IQ 150S/250S Self-Enclosed Electronic Meters	V3-T9-46
IQ 35M	V3-T9-51
IQ Analyzer 6400/6600 Series	V3-T9-54
IQ DP-4000 Series	V3-T9-62
Power Xpert Multi-Point Meter	V3-T9-68
PM3 Monitoring and Metering Module	
Current Transformers (CTs)	V3-T9-81
Clamp-On Current Transformers	V3-T9-90
IQ Flange	V3-T9-93
Panel Mounting Adapter Kit	V3-T9-94
Enclosed Meters	V3-T9-95

PM3 Monitoring and Metering Module

Product Description

For information on our PM3 product, please refer to **Volume 4, Tab 2**.

Current Transformers (CTs)

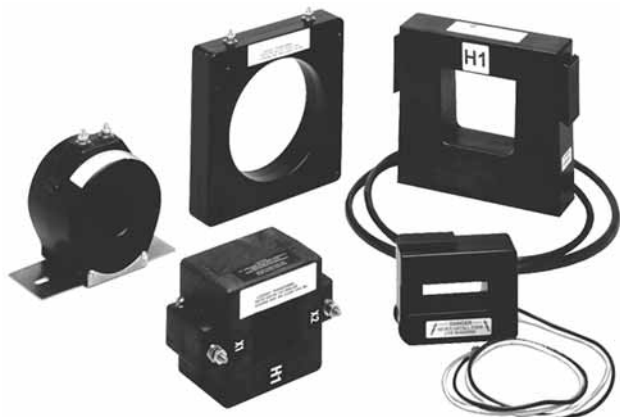

Current Transformers (CTs)

Product Description

Eaton’s low voltage current transformers are available in both solid core and split core designs. Engineered for electronic metering applications, all solid core designs and selected split core designs offer ANSI metering quality accuracy. The solid core designs also meet ANSI C57.13 relay accuracy requirements including over-ranging capabilities. The current transformer offering has a 5 ampere secondary at the rated primary current.

Split core CTs are specifically designed to be installed around primary conductors without disconnecting wires or breaking the circuit to be monitored. These current transformers are perfect solutions for energy management applications and are manufactured for installation ease.

Contents

<i>Description</i>	<i>Page</i>
Metering Products Family	V3-T9-6
Power Xpert Meter 4000/6000/8000 Series	V3-T9-13
Power Xpert Meter 2000 Series	V3-T9-26
IQ 250/260 Series Electronic Power Meters	V3-T9-35
IQ 130/140/150 Series Electronic Power Meters	V3-T9-41
IQ 150S/250S Self-Enclosed Electronic Meters	V3-T9-46
IQ 35M	V3-T9-51
IQ Analyzer 6400/6600 Series	V3-T9-54
IQ DP-4000 Series	V3-T9-62
Power Xpert Multi-Point Meter	V3-T9-68
PM3 Monitoring and Metering Module	V3-T9-80
Current Transformers (CTs)	
Product Selection	V3-T9-82
Dimensions	V3-T9-85
Clamp-On Current Transformers	V3-T9-90
IQ Flange	V3-T9-93
Panel Mounting Adapter Kit	V3-T9-94
Enclosed Meters	V3-T9-95

Application Description

For new construction and retrofit applications where no current transformer exists, Eaton offers a complete selection of low voltage (up to 600V) current transformers. These current transformers can be used in commercial-grade applications, such as control panels and panelboards. Additionally, they can be used for most industrial metering and relaying applications in switchboards, switchgear and motor control centers. These CTs are intended for use with the Power Xpert Meter 2000/4000/6000/8000, IQ 250/260, IQ 130/140/150, IQ Analyzer 6400/6600, IQ DP-4000 and IQ 230 series.

Product Selection

Solid Core ANSI Metering Accuracy

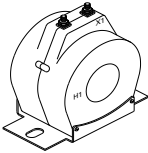
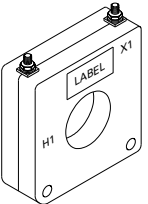
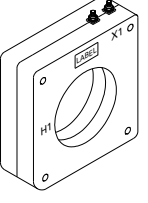
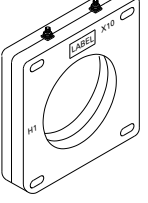
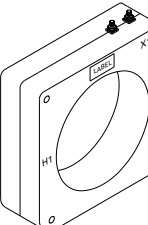
	Primary Current Rating	ANSI B0.1 Metering Class at 60 Hz (Accuracy in %)	Window Size in Inches (mm) Diameter	Catalog Number	Mounting Bracket Catalog Number
S060 	1.25 (31.8) Window				
	50	1.2	1.25 (31.8)	S060-500	①
	100	0.6	1.25 (31.8)	S060-101	①
	150	0.3	1.25 (31.8)	S060-151	①
	200	0.3	1.25 (31.8)	S060-201	①
S050 	1.56 (39.6) Window				
	300	0.3	1.56 (39.6)	S050-301	S050BRAC
	400	0.3	1.56 (39.6)	S050-401	S050BRAC
	500	0.3	1.56 (39.6)	S050-501	S050BRAC
	600	0.3	1.56 (39.6)	S050-601	S050BRAC
	750	0.3	1.56 (39.6)	S050-751	S050BRAC
	800	0.3	1.56 (39.6)	S050-801	S050BRAC
	1000	0.3	1.56 (39.6)	S050-102	S050BRAC
	1200	0.3	1.56 (39.6)	S050-122	S050BRAC
	S080 	3.25 (82.6) Window			
400		0.3	3.25 (82.6)	S080-401	S080BRAC
500		0.3	3.25 (82.6)	S080-501	S080BRAC
600		0.3	3.25 (82.6)	S080-601	S080BRAC
750		0.3	3.25 (82.6)	S080-751	S080BRAC
800		0.3	3.25 (82.6)	S080-801	S080BRAC
1000		0.3	3.25 (82.6)	S080-102	S080BRAC
1200		0.3	3.25 (82.6)	S080-122	S080BRAC
S090 	4.25 (108.0) Window				
	500	0.3	4.25 (108.0)	S090-501	S090BRAC
	600	0.3	4.25 (108.0)	S090-601	S090BRAC
	750	0.3	4.25 (108.0)	S090-751	S090BRAC
	800	0.3	4.25 (108.0)	S090-801	S090BRAC
	1000	0.3	4.25 (108.0)	S090-102	S090BRAC
	1200	0.3	4.25 (108.0)	S090-122	S090BRAC
	1500	0.3	4.25 (108.0)	S090-152	S090BRAC
	1600	0.3	4.25 (108.0)	S090-162	S090BRAC
	2000	0.3	4.25 (108.0)	S090-202	S090BRAC
	2500	0.3	4.25 (108.0)	S090-252	S090BRAC
	3000	0.3	4.25 (108.0)	S090-302	S090BRAC
	S025 	6.31 (160.3) Window			
600		0.3	6.31 (160.3)	S025-601	S025BRAC
750		0.3	6.31 (160.3)	S025-751	S025BRAC
800		0.3	6.31 (160.3)	S025-801	S025BRAC
1000		0.3	6.31 (160.3)	S025-102	S025BRAC
1200		0.3	6.31 (160.3)	S025-122	S025BRAC
1500		0.3	6.31 (160.3)	S025-152	S025BRAC
1600		0.3	6.31 (160.3)	S025-162	S025BRAC
2000		0.3	6.31 (160.3)	S025-202	S025BRAC
2500		0.3	6.31 (160.3)	S025-252	S025BRAC
3000		0.3	6.31 (160.3)	S025-302	S025BRAC
3500		0.3	6.31 (160.3)	S025-352	S025BRAC
4000		0.3	6.31 (160.3)	S025-402	S025BRAC

Note

① Contact Eaton for further information.

Split Core ANSI Metering Accuracy

Primary Current Rating	ANSI B0.1 Metering Class at 60 Hz (Accuracy in %)	Window Size in Inches (mm)	Catalog Number
------------------------	---	----------------------------	----------------

W190

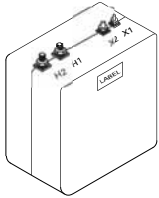

Wound and Primary CTs			
25	0.3	Wound	W190-025
50	0.3	Primary	W190-050

M000

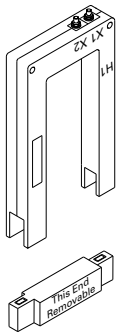

2.00 x 5.50 (50.8 x 139.7)			
400	2.4	2.00 x 5.50 (50.8 x 139.7)	M000-401
500	2.4	2.00 x 5.50 (50.8 x 139.7)	M000-501
600	2.4	2.00 x 5.50 (50.8 x 139.7)	M000-601
800	1.2	2.00 x 5.50 (50.8 x 139.7)	M000-801
1000	1.2	2.00 x 5.50 (50.8 x 139.7)	M000-102
1200	0.6	2.00 x 5.50 (50.8 x 139.7)	M000-122
1500	0.6	2.00 x 5.50 (50.8 x 139.7)	M000-152
1600	0.6	2.00 x 5.50 (50.8 x 139.7)	M000-162
2000	0.6	2.00 x 5.50 (50.8 x 139.7)	M000-202

M050

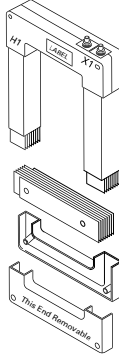

4.10 x 7.10 (104.1 x 180.3)			
600	4.8	4.10 x 7.10 (104.1 x 180.3)	M050-601
750	4.8	4.10 x 7.10 (104.1 x 180.3)	M050-751
800	2.4	4.10 x 7.10 (104.1 x 180.3)	M050-801
1000	2.4	4.10 x 7.10 (104.1 x 180.3)	M050-102
1200	1.2	4.10 x 7.10 (104.1 x 180.3)	M050-122
1500	1.2	4.10 x 7.10 (104.1 x 180.3)	M050-152
2000	0.6	4.10 x 7.10 (104.1 x 180.3)	M050-202
2500	0.6	4.10 x 7.10 (104.1 x 180.3)	M050-252
3000	0.6	4.10 x 7.10 (104.1 x 180.3)	M050-302
3500	0.6	4.10 x 7.10 (104.1 x 180.3)	M050-352
4000	0.3	4.10 x 7.10 (104.1 x 180.3)	M050-402

Split Core Current Transformers

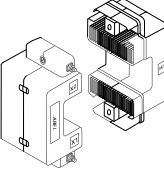
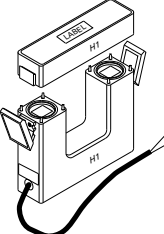
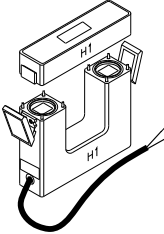
	Primary Current Rating	Accuracy at 60 Hz (in %)	Window Size in Inches (mm)	Catalog Number
M030 	0.80 x 1.95 (20.3 x 49.5)			
	100	5.0	0.80 x 1.95 (20.3 x 49.5)	M030-101
	150	5.0	0.80 x 1.95 (20.3 x 49.5)	M030-151
	200	4.0	0.80 x 1.95 (20.3 x 49.5)	M030-201
	300	2.0	0.80 x 1.95 (20.3 x 49.5)	M030-301
	400	2.0	0.80 x 1.95 (20.3 x 49.5)	M030-401
M040 	1.42 x 1.53 (36.1 x 38.9)			
	100	5.0	1.42 x 1.53 (36.1 x 38.9)	M040-101
	150	4.0	1.42 x 1.53 (36.1 x 38.9)	M040-151
	200	1.5	1.42 x 1.53 (36.1 x 38.9)	M040-201
	300	1.5	1.42 x 1.53 (36.1 x 38.9)	M040-301
	400	1.5	1.42 x 1.53 (36.1 x 38.9)	M040-401
M060 	2.60 x 2.75 (66.0 x 69.9)			
	200	1.0	2.60 x 2.75 (66.0 x 69.9)	M060-201
	300	1.0	2.60 x 2.75 (66.0 x 69.9)	M060-301
	400	1.0	2.60 x 2.75 (66.0 x 69.9)	M060-401
	500	1.0	2.60 x 2.75 (66.0 x 69.9)	M060-501
	600	1.0	2.60 x 2.75 (66.0 x 69.9)	M060-601
	750	1.0	2.60 x 2.75 (66.0 x 69.9)	M060-751
	800	1.0	2.60 x 2.75 (66.0 x 69.9)	M060-801
	1000	1.0	2.60 x 2.75 (66.0 x 69.9)	M060-102
	1200	1.0	2.60 x 2.75 (66.0 x 69.9)	M060-122
M080 	2.60 x 6.25 (66.0 x 158.8)			
	500	1.0	2.60 x 6.25 (66.0 x 158.8)	M080-501
	600	1.0	2.60 x 6.25 (66.0 x 158.8)	M080-601
	800	1.0	2.60 x 6.25 (66.0 x 158.8)	M080-801
	1000	1.0	2.60 x 6.25 (66.0 x 158.8)	M080-102
	1200	1.0	2.60 x 6.25 (66.0 x 158.8)	M080-122
	1500	1.0	2.60 x 6.25 (66.0 x 158.8)	M080-152
	1600	1.0	2.60 x 6.25 (66.0 x 158.8)	M080-162
	2000	1.0	2.60 x 6.25 (66.0 x 158.8)	M080-202
	2500	1.0	2.60 x 6.25 (66.0 x 158.8)	M080-252
	3000	1.0	2.60 x 6.25 (66.0 x 158.8)	M080-302

Dimensions

Approximate dimensions in inches (mm)

S050

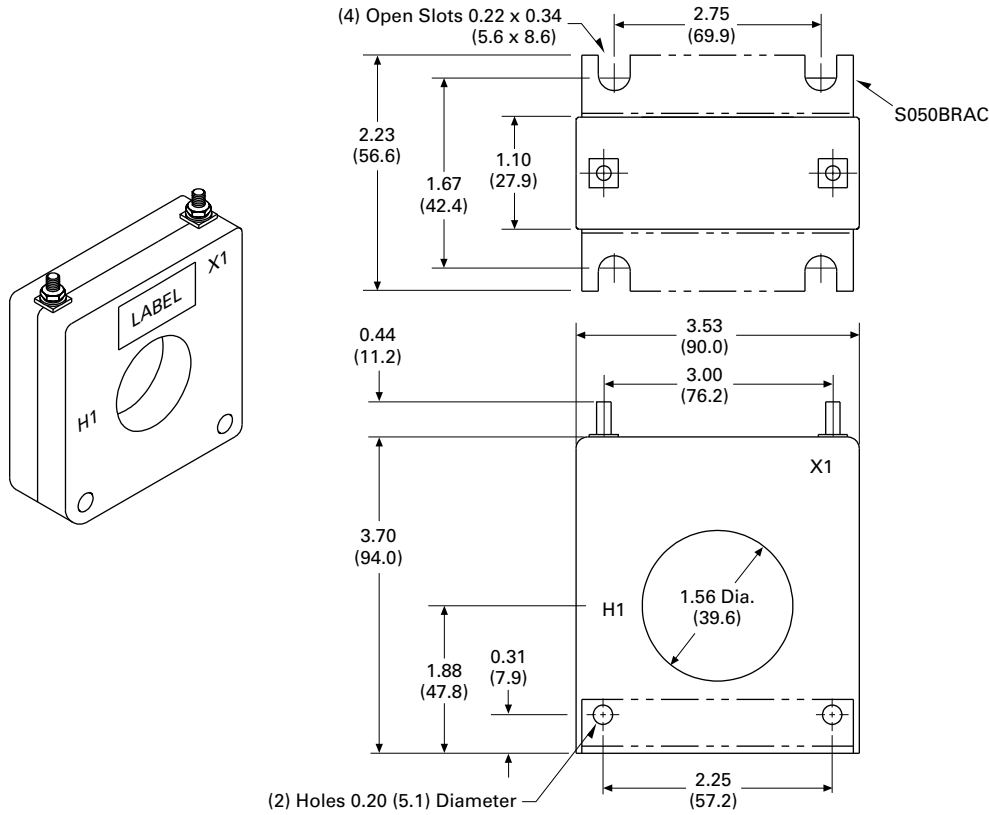

S060

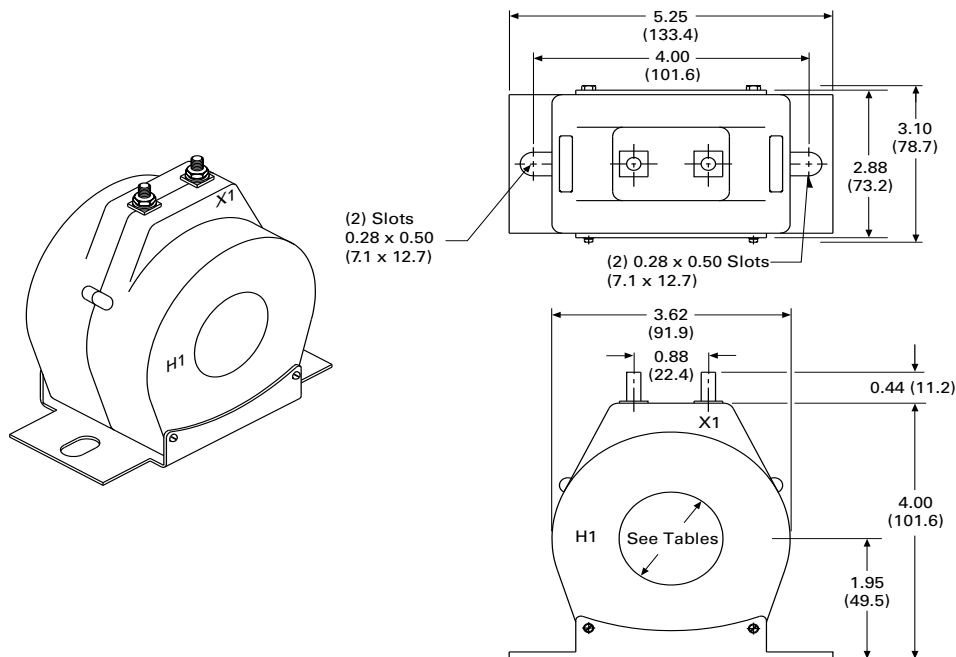

9.2

Metering Devices, Protective Relays, Software and Connectivity

Metering Devices

Approximate dimensions in inches (mm)

S080

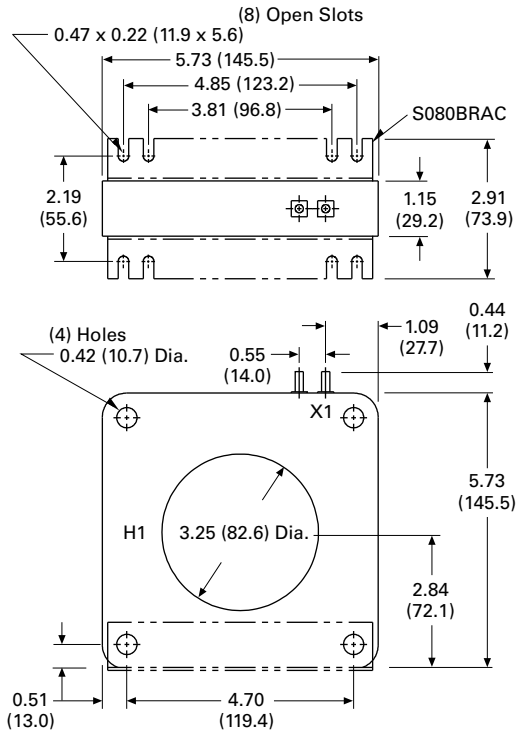
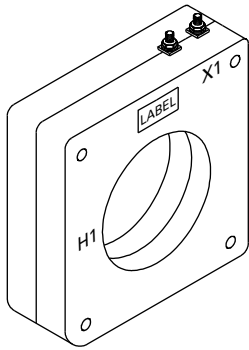

S090

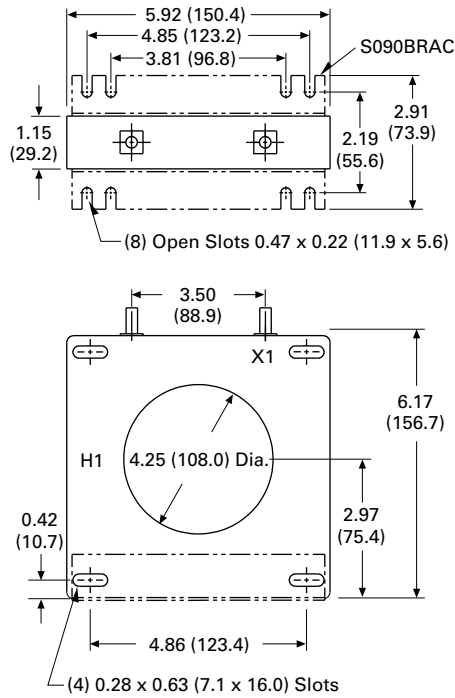
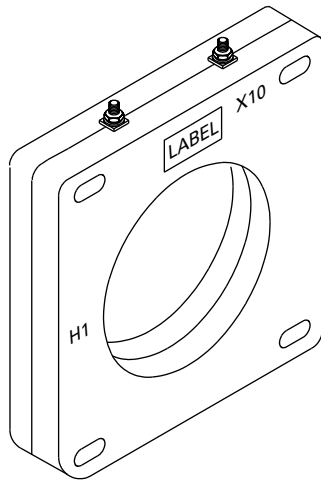

Approximate dimensions in inches (mm)

S025

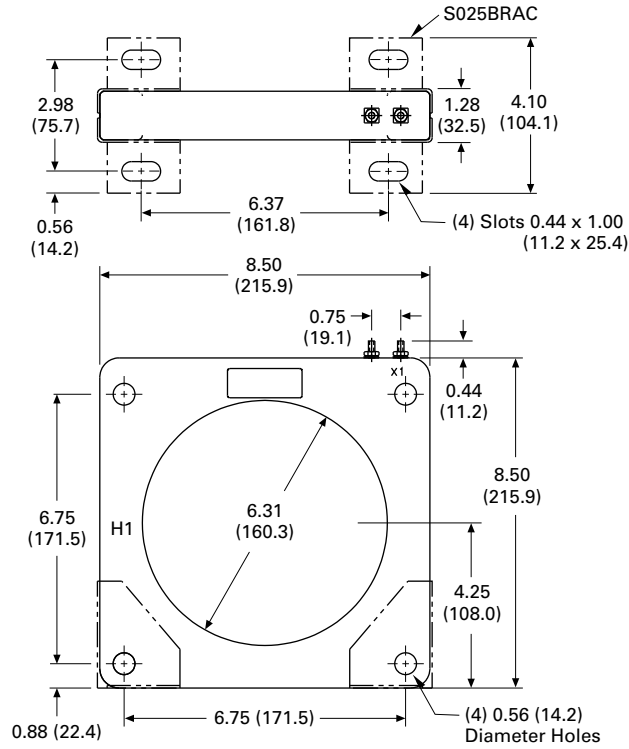
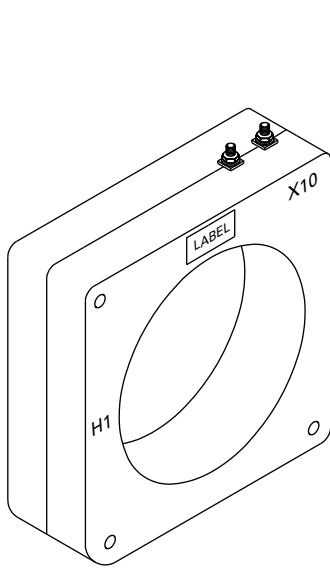

W190

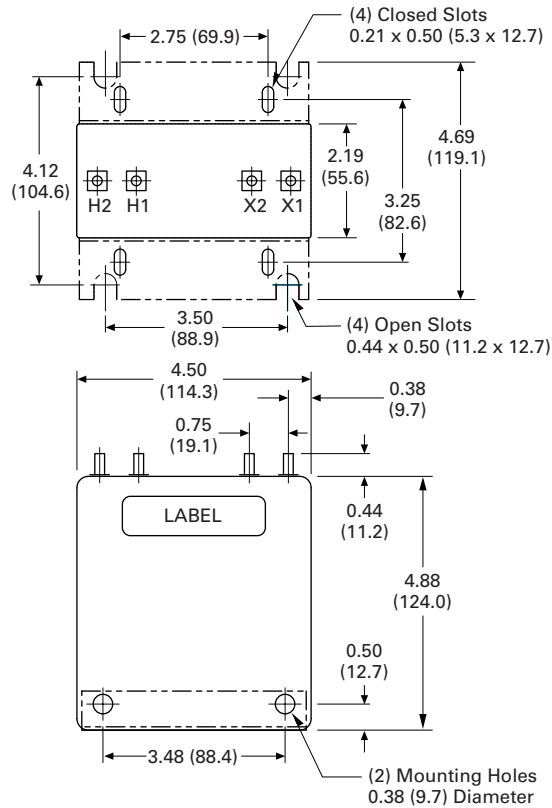
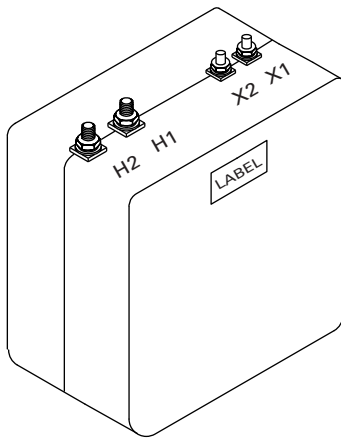

9.2

Metering Devices, Protective Relays, Software and Connectivity

Metering Devices

Approximate dimensions in inches (mm)

M000

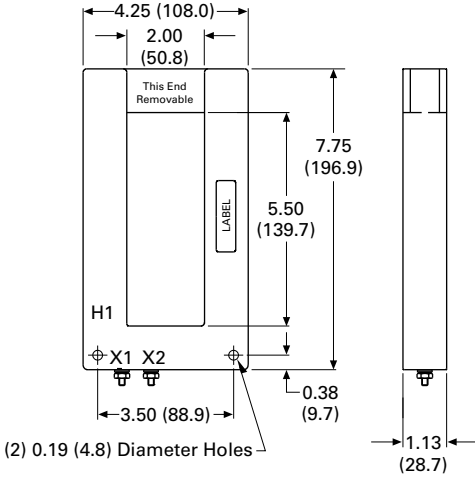
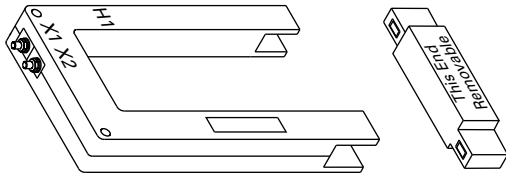

M050

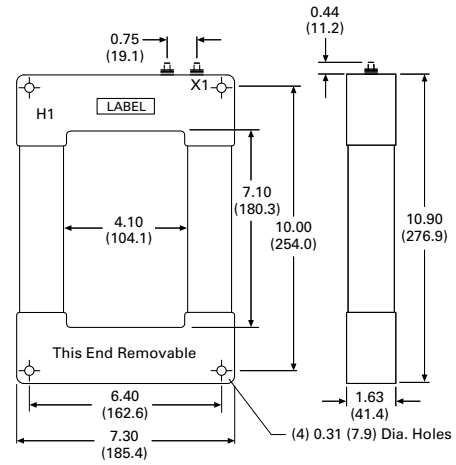
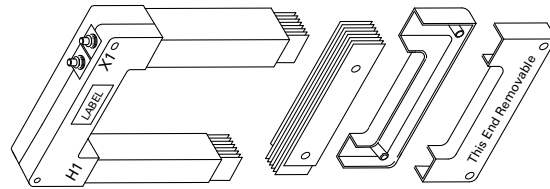

M030

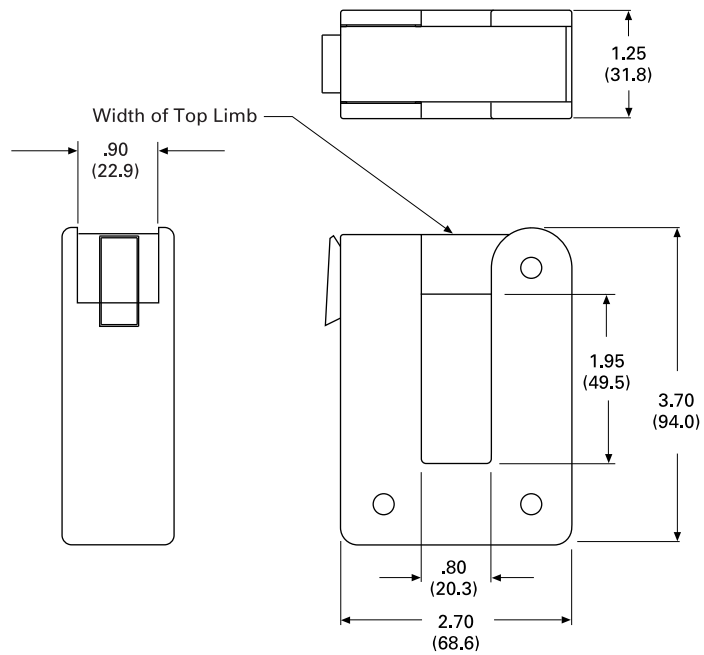
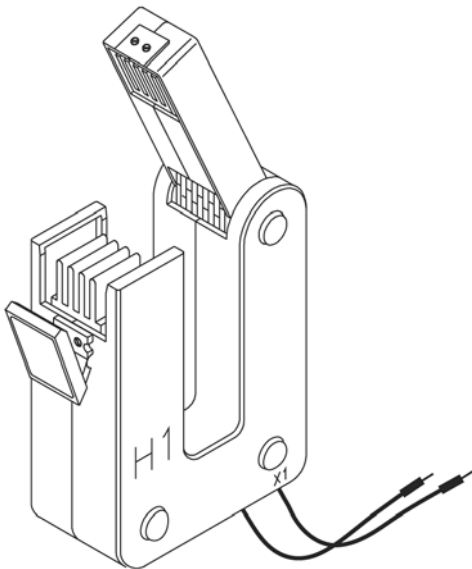

Approximate dimensions in inches (mm)

M040

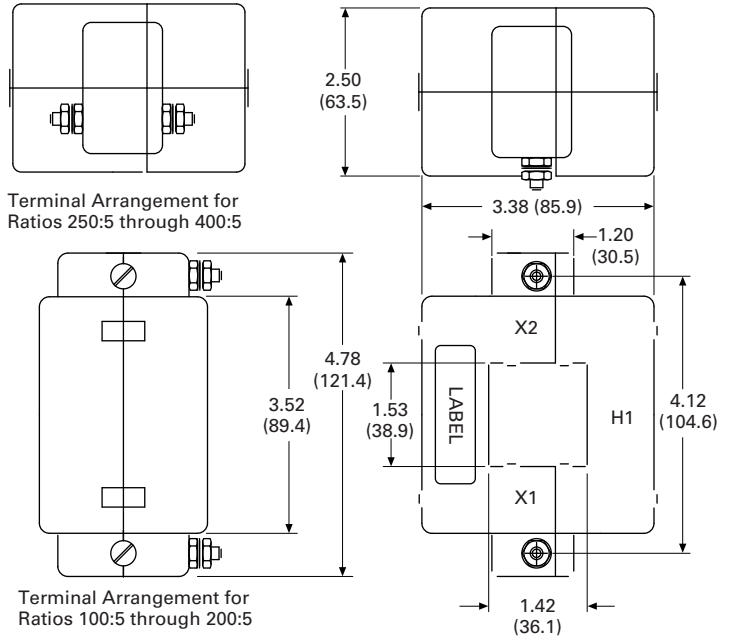
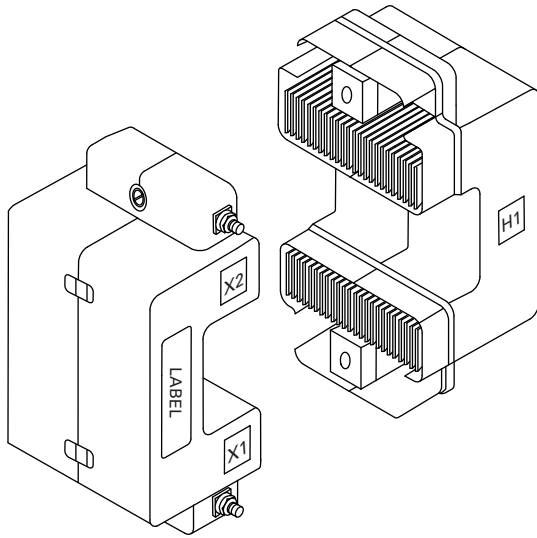

M060

M080

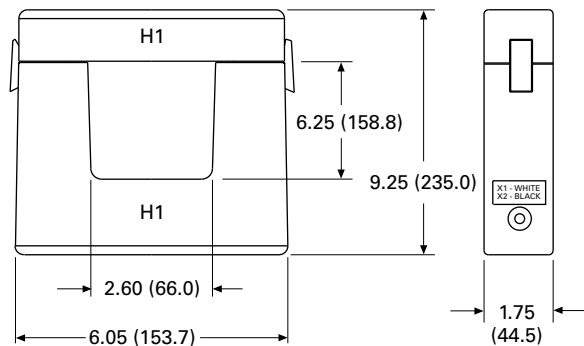
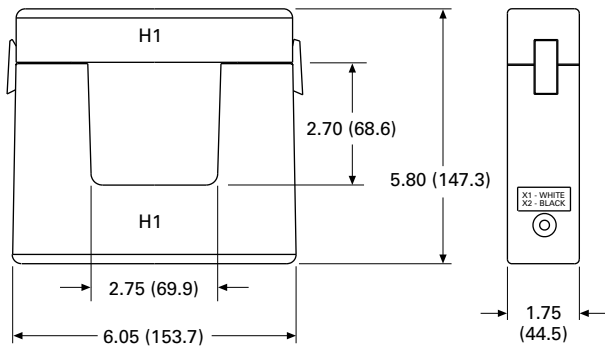
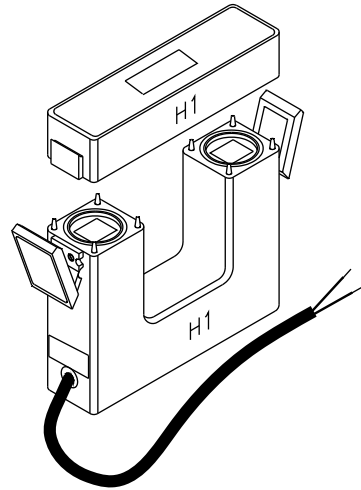
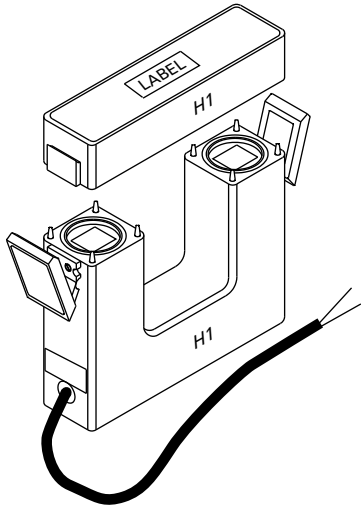

IQ Accessories—Clamp-On CTs



Contents

<i>Description</i>	<i>Page</i>
Metering Products Family	V3-T9-6
Power Xpert Meter 4000/6000/8000 Series	V3-T9-13
Power Xpert Meter 2000 Series	V3-T9-26
IQ 250/260 Series Electronic Power Meters	V3-T9-35
IQ 130/140/150 Series Electronic Power Meters	V3-T9-41
IQ 150S/250S Self-Enclosed Electronic Meters	V3-T9-46
IQ 35M	V3-T9-51
IQ Analyzer 6400/6600 Series	V3-T9-54
IQ DP-4000 Series	V3-T9-62
Power Xpert Multi-Point Meter	V3-T9-68
PM3 Monitoring and Metering Module	V3-T9-80
Current Transformers (CTs)	V3-T9-81
Clamp-On Current Transformers	
Product Selection	V3-T9-91
Technical Data and Specifications	V3-T9-91
Dimensions	V3-T9-92
IQ Flange	V3-T9-93
Panel Mounting Adapter Kit	V3-T9-94
Enclosed Meters	V3-T9-95

Clamp-On Current Transformers

Product Description

Eaton’s optional Clamp-on Current Transformers (CTs) are designed to be used in cases where there are no existing CTs or the existing CTs cannot be accessed, these clamp-on CTs can be used.

These clamp-on CTs are packaged individually. Most applications will require at least three clamp-on CTs, one for each phase.

Application Description

- There are two models that cover current ranges from 150 to 1500 amperes
- These clamp-on CTs are designed to fit around 600 volt insulated cable and bus bar

Features, Benefits and Functions

- Each clamp-on CT comes with a 12-foot (3.7m) cable and twist lock connector
- All models have a 5 ampere output at three different primary current ratings



Standards and Certifications

- Meets IEC 1010-1 Category III
- CE mark for applications where European compliance is required



Product Selection

Ordering Information

	Current Ranges	Catalog Number
	150-300-600A	IQAPORT0600CT
	500-1000-1500A	IQAPORT1500CT

Technical Data and Specifications

- Operating temperature: 14°F to 122°F (–10°C to 50°C)
- Operating humidity: 5 to 90% maximum noncondensing
- Altitude: 10,000 ft (3048m)
- Environment: indoor use only
- Operating voltage: 600 Vac maximum
- Isolation test: 5.55 kV for 1 minute
- Current over range: 200% for 3 minutes
- Connector: twist-lock

Current Ranges

Each of the two models of clamp-on CTs has three primary current ranges. The primary current range is selected at the clamp-on by connecting to the indicated terminals.

150A/300A/600A Clamp-On CT Specifications

- Current ratings:
 - 150 to 5 amperes
 - 300 to 5 amperes
 - 600 to 5 amperes

500A/1000A/1500A Clamp-On CT Specifications

- Current ratings:
 - 500 to 5 amperes
 - 1000 to 5 amperes
 - 1500 to 5 amperes

Electrical Characteristics

Current Ranges	Load (Ohms)	Phase Shift (Degree)	Frequency Range (3%)	Frequency Range (–3 db)
150–600A	0.10–1.0	0.5–1.0	40–5000	30–10,000
500–1500A	0.01–4.0	0.5–1.0	40–2000	30–5000

Dimensions

Approximate Dimensions in Inches (mm)

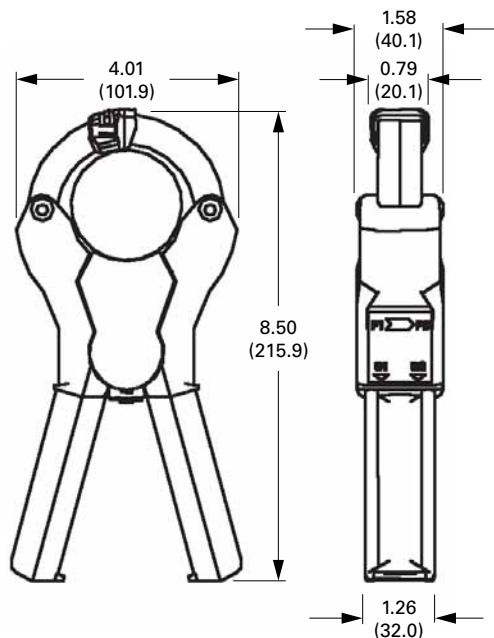
150A/300A/600A Clamp-On CT**150A/300A/600A Clamp-On CT**

- Maximum cable size:
 - 2.00 inches (50.8 mm)
- Maximum bus bar size:
 - 2.00 x 0.47 inches (50.8 x 12.0 mm)
 - 1.60 x 1.40 inches (40.6 x 35.6 mm)
- Dimensions (without cable):
 - 4.00 x 8.50 x 1.60 inches (101.6 x 215.9 x 40.6 mm)
- Weight (with cable):
 - 2.0 lbs (0.9 kg)

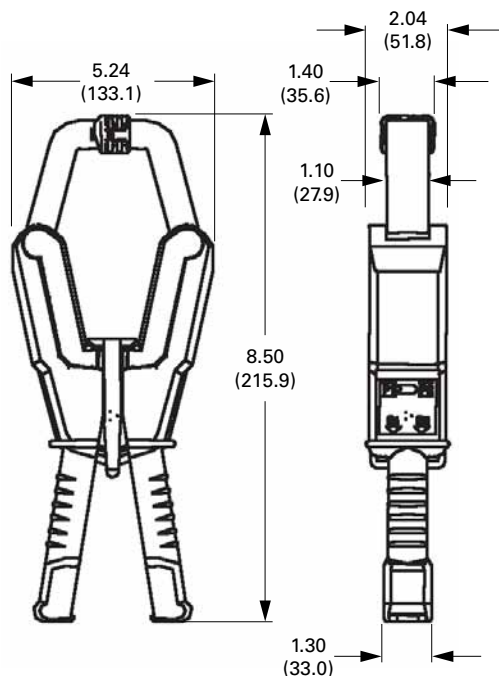
500A/1000A/1500A Clamp-On CT**500A/1000A/1500A Clamp-On CT**

- Maximum cable size:
 - 2.68 inches (68.1 mm)
- Maximum bus bar size:
 - 4.84 x 1.40 (122.9 x 35.6 mm)
 - 4.00 x 1.70 inches (101.6 x 43.2 mm)
- Dimensions (without cable):
 - 5.20 x 13.20 x 2.00 inches (132.1 x 335.3 x 50.8 mm)
- Weight (with cable):
 - 6.0 lbs (2.7 kg)

IQ Accessories—IQ Flange



IQ Flange

Product Description

Eaton’s IQ Flange is intended for use with the IQ Data, IQ Generator, IQ Data Plus II, IQ Analyzer and any other such device sharing the same mounting dimensions.

The door mounting flange provides extra depth behind a panel if there is not enough clearance to accommodate the device.

Application Description

Retrofit Applications

For applications where extra door mounting space is required, a flange-mounting unit is available. The IQ Flange provides an extra 2.5 inches (63.5 mm) of clearance for the device. The IQ Flange can be used with any IQ device with a 5.38-inch (136.7 mm) x 9.38-inch (238.0 mm) cutout.

Contents

<i>Description</i>	<i>Page</i>
Metering Products Family	V3-T9-6
Power Xpert Meter 4000/6000/8000 Series	V3-T9-13
Power Xpert Meter 2000 Series	V3-T9-26
IQ 250/260 Series Electronic Power Meters	V3-T9-35
IQ 130/140/150 Series Electronic Power Meters	V3-T9-41
IQ 150S/250S Self-Enclosed Electronic Meters	V3-T9-46
IQ 35M	V3-T9-51
IQ Analyzer 6400/6600 Series	V3-T9-54
IQ DP-4000 Series	V3-T9-62
Power Xpert Multi-Point Meter	V3-T9-68
PM3 Monitoring and Metering Module	V3-T9-80
Current Transformers (CTs)	V3-T9-81
Clamp-On Current Transformers	V3-T9-90
IQ Flange	
Panel Mounting Adapter Kit	V3-T9-94
Enclosed Meters	V3-T9-95

Product Selection

IQ Flange



IQ Flange

Description	Catalog Number
IQ Flange	IQFLANGE

Panel Mounting Adapter Kit for IQ 100/200 Series and PXM 2000 Meters



9

Panel Mounting Adapter Kit for IQ 100/200 Series and PXM 2000 Meters

Product Description

The flange adapter plate can be installed as follows:

1. Remove the old meter from the panel or door. Many IQ metering products use the typical IQ drilling pattern shown at right for mounting
2. Install the flange adapter plate. Mount it from the rear using the six screws provided in the kit. The flange adapter plate screw hole pattern shown at right should match the typical IQ drilling pattern. If not, perform the next step
3. Drill six holes in the panel or the door to mount the flange adapter plate. Follow the typical IQ drilling pattern. You need only the top, center and bottom sets of holes
4. Install the new IQ 100/200 Series or PXM 2000 meter in the flange adapter plate. Secure it from behind with four flat washers, lock washers and nuts provided with the meter

Contents

<i>Description</i>	<i>Page</i>
Metering Products Family	V3-T9-6
Power Xpert Meter 4000/6000/8000 Series	V3-T9-13
Power Xpert Meter 2000 Series	V3-T9-26
IQ 250/260 Series Electronic Power Meters	V3-T9-35
IQ 130/140/150 Series Electronic Power Meters	V3-T9-41
IQ 150S/250S Self-Enclosed Electronic Meters	V3-T9-46
IQ 35M	V3-T9-51
IQ Analyzer 6400/6600 Series	V3-T9-54
IQ DP-4000 Series	V3-T9-62
Power Xpert Multi-Point Meter	V3-T9-68
PM3 Monitoring and Metering Module	V3-T9-80
Current Transformers (CTs)	V3-T9-81
Clamp-On Current Transformers	V3-T9-90
IQ Flange	V3-T9-93
Panel Mounting Adapter Kit	
Enclosed Meters	V3-T9-95

Product Selection

Panel Mounting Adapter Kit



Panel Mounting Adapter Kit

Description	Catalog Number
Panel mounting adapter kit IQ 100/200 and PXM 2000 Series adapter kit to IQ Analyzer/IQ DP-4000/IQ Data	IQ250-PMAK

Dimensions

Flange Adapter Plate Screw Hole Pattern

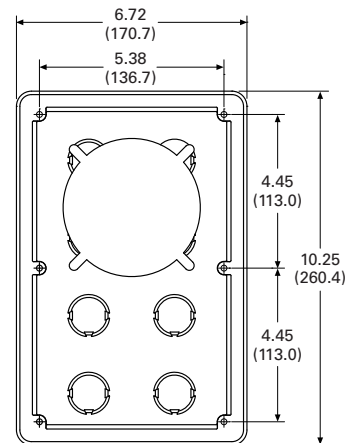

NEMA 12 Single- and Multi-Unit Enclosed Meters



Contents

<i>Description</i>	<i>Page</i>
Metering Products Family	V3-T9-6
Power Xpert Meter 4000/6000/8000 Series	V3-T9-13
Power Xpert Meter 2000 Series	V3-T9-26
IQ 250/260 Series Electronic Power Meters	V3-T9-35
IQ 130/140/150 Series Electronic Power Meters	V3-T9-41
IQ 150S/250S Self-Enclosed Electronic Meters	V3-T9-46
IQ 35M	V3-T9-51
IQ Analyzer 6400/6600 Series	V3-T9-54
IQ DP-4000 Series	V3-T9-62
Power Xpert Multi-Point Meter	V3-T9-68
PM3 Monitoring and Metering Module	V3-T9-80
Current Transformers (CTs)	V3-T9-81
Clamp-On Current Transformers	V3-T9-90
IQ Flange	V3-T9-93
Panel Mounting Adapter Kit	V3-T9-94
Enclosed Meters	
Features and Benefits	V3-T9-96
Catalog Number Selection	V3-T9-98
Product Selection	V3-T9-99
Technical Data and Specifications	V3-T9-99
Wiring Diagrams	V3-T9-100
Dimensions	V3-T9-110

Enclosed Meters

Product Description

The Eaton enclosed meter line provides a complete energy metering and data acquisition solution in a single enclosure. Designed for Eaton’s IQ 35M, IQ 150, IQ 250/260, and Power Xpert® 2000/4000/6000/8000 and Multi-Point Meters, Eaton’s enclosed meter line offers mounting and installation flexibility, especially in retrofit applications where no metering compartment or mounting space is available in the existing electrical distribution equipment or where installation time is a premium. Factory designed and wired, Eaton’s enclosed meter line offers savings in labor and installation costs because input current and voltage wiring as well as I/O wiring is prewired to terminal blocks inside the enclosure.

The enclosed meter line has two standard offerings: single-, prewired unit (specific IQ 150, IQ 250/260, PXM 2000, PXM 4000/6000/8000 or PXMP) and a multi-unit (specific IQ 150, IQ 250/260 or IQ 35M models). Because the multi-unit can be configured to include Eaton’s Power Xpert Gateway 900, it can facilitate measurement and verification of the energy usage on processes and in buildings. This provides a convenient way to monitor energy usage from multiple points, collect and log specific energy use parameters, and display and generate logs for historical energy usage reports. Simply put, Eaton’s multi-unit enclosed meter solution helps meet any measurement and verification requirement to show energy efficiency improvements and results. In addition to the standard offering, Eaton can also provide an enclosed metering solution tailored around your project needs.

Application Description

Factory designed and wired to fit various Eaton power and energy meters at varying price points, Eaton’s enclosed meter line offers savings in labor and installation costs because input current and voltage wiring, as well as I/O wiring, is prewired to terminal blocks inside the enclosure. Standalone, enclosed meters are ideal for new metering applications where no metering existed previously, for retrofit installations where energy monitoring is a must or where ease of installation is required.

- Health care facilities
- Educational facilities and campuses
- Industrial facilities
- Commercial facilities
- Government facilities

The multi-unit offering consolidates energy-related data available from the meters in the enclosure, but also allows for external meters to be added to the embedded Power Xpert Gateway 900, if selected to be included in the enclosed meter. Through the Power Xpert Gateway 900’s embedded Web server, information can be presented in a variety of ways; a standard Web browser being the most widely used method.

The enclosed product is a standalone solution that is ideal for many infrastructure designs. Further, as needs change and grow, the enclosed product can be integrated through Power Xpert Insight into a broader solution that encompasses other intelligent hardware and can integrate with third-party network management systems (NMS) or building management systems (BMS) for system-wide monitoring and reporting of energy and power.

Features and Benefits

- Saves installation time and cost
- One part number to order; no need to worry that any part has been left out
- Pick the meter or meters you need as it is designed to fit various Eaton power and energy meters, at varying price points

Factory Wired

Most electrical contractors are very familiar with wiring meters. However, it does take time to place the disconnect, the CT shorting blocks, the terminal blocks, the control power transformer and so on, and the associated wiring. It is not uncommon for errors to be introduced during the installation of multiple meters; it's just inherent in wiring. With Eaton's enclosed meter line, everything is wired at the factory—the shorting block, the terminal blocks and so on—assuring that it's done right. Further, to ensure safety, Eaton's enclosed meter line includes a primary fusible disconnect for line voltage, which can be turned off during meter maintenance.

For applications with line voltages above the rated power supply of the meter, an optional control power transformer is supplied in the enclosure. Control voltage can also be supplied via a separate source that is wired to the field installation terminal block. CT inputs for the meter are wired directly to the shorting terminal blocks for easy field installation.

Factory-wired products also save on installation time and costs. The meters are flush mounted on the enclosure door with all inputs/outputs factory wired to the terminal blocks.

A meter subpanel assembly is also available, which includes all the internal components of the single-unit enclosed meter for the IQ 150/250/260 and PXM 2000 Meters wired and mounted on a subpanel to be installed into an existing electrical structure. It comes with a 48-inch lead for flexibility in mounting the meters at various distances.

NEMA Rated

NEMA 12 enclosure prevents dust and other materials from entering the equipment. Internal gaskets also prevent air irritants from harming the vital equipment inside. This quality enclosure meets most indoor application needs.

NEMA 3R enclosure is constructed for either indoor or outdoor use. It helps to protect personnel from access to hazardous parts and provides a degree of protection for equipment inside the enclosure against ingress of solid foreign objects (falling dirt), harmful effects of water (rain, sleet, snow) and external formation of ice on the enclosure.

NEMA 4X enclosure provides the same degree of protection as the NEMA 3R with the additional protection against windblown dust, splashing and hose-directed water, and corrosion.

NEMA 12 Front View, Door Open, Prewired and Tested

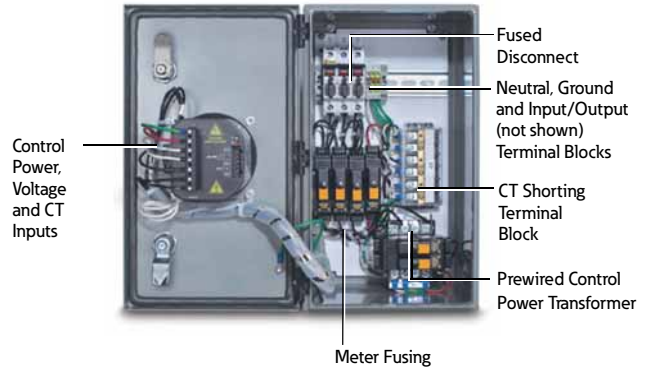

NEMA 12 Multi-Unit View, Door Open, Prewired and Tested

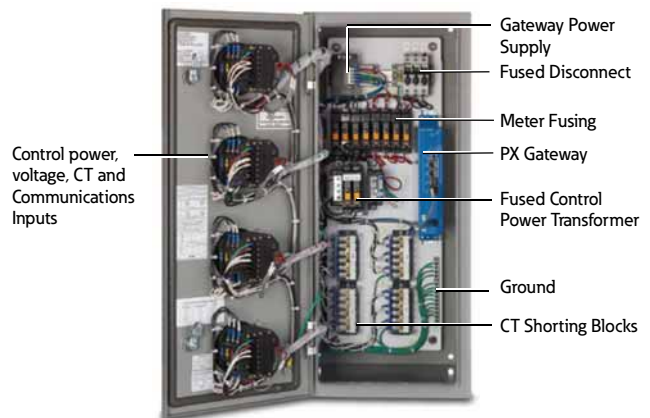

NEMA 12 Single-Unit Enclosed Meter Inside View, PXM 4000/6000/8000 Series

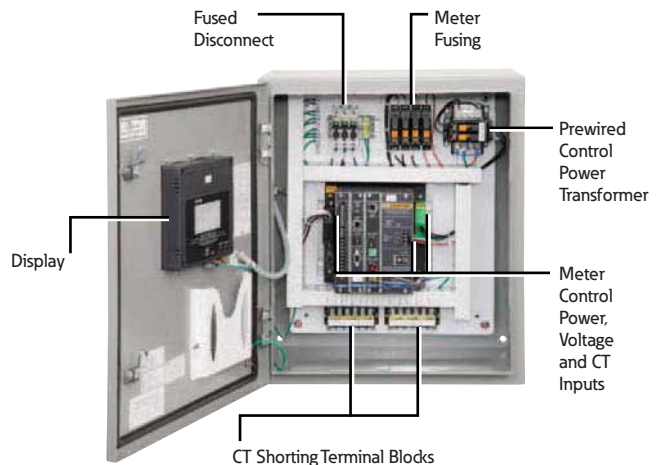

NEMA 3R Single-Unit Closed and Open, IQ 150/250/260 and PXM 2000 Series



NEMA 4X Single-Unit Closed and Open, IQ 150/250/260 and PXM 2000 Series



Multi-Unit Enclosed Meter, Inside View of IQ 35M



Prewired Meter Backpan, Single Unit

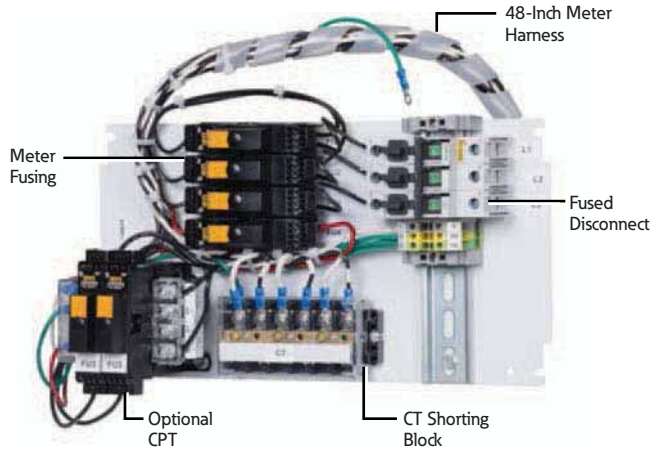

Enclosed Power Xpert Multi-Point Meter

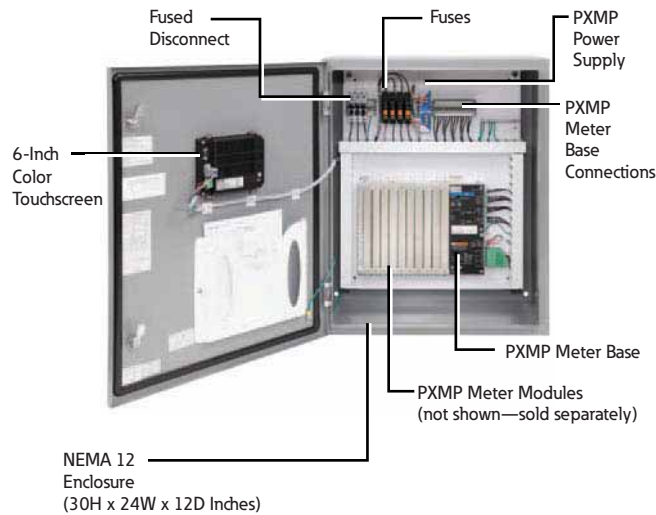

- Prewired panel to save installation time and cost for retrofits into existing equipment
- Designed for Eaton's:
 - IQ 100 Meter Series
 - IQ 250/260
 - Power Xpert Meter 2000 Series
- With or without CPT, depending on voltage
- Order meters separately

Enclosed Power Xpert Branch Circuit Monitor

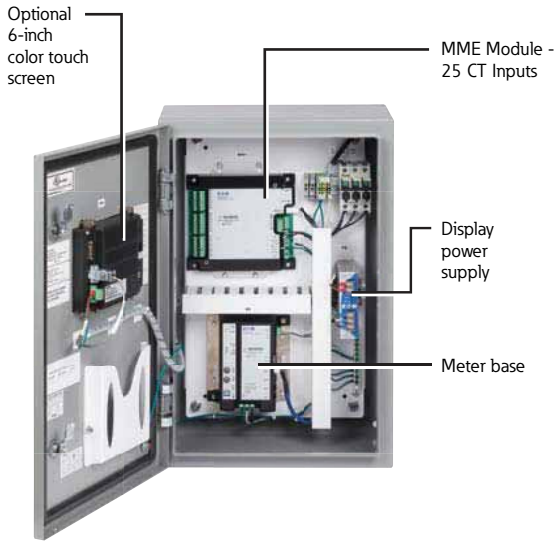

Enclosed PXMP Meter

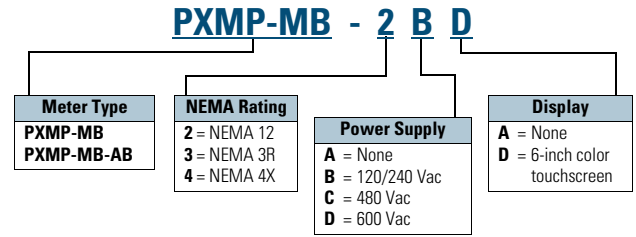

Multi Unit Enclosed Meter

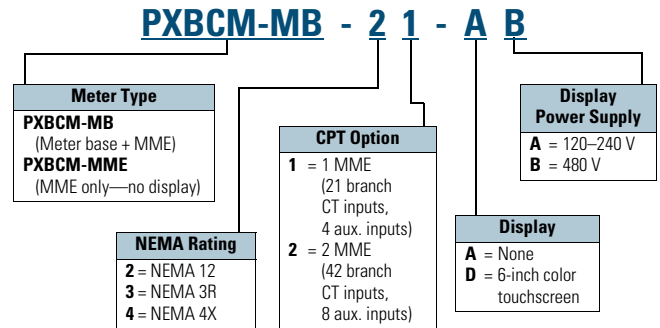

Catalog Number Selection

Single Unit Enclosed Meter

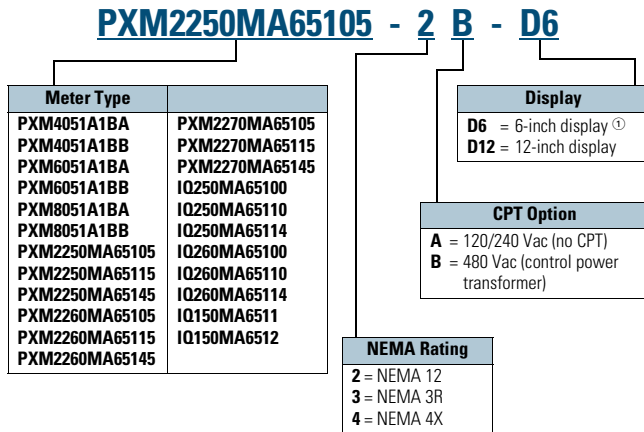

Multi-Unit Enclosed Meter

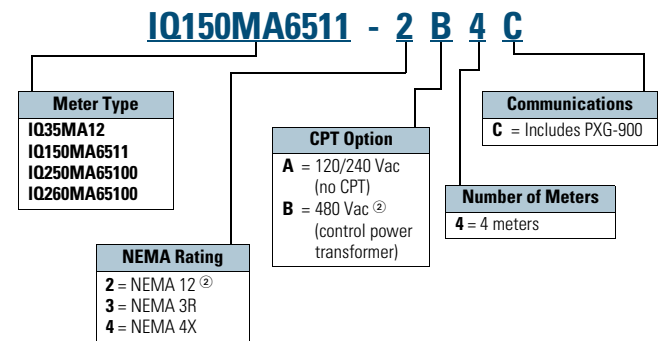

Notes

- ① Only available for the PXM4000/6000/8000.
- ② Not available with IQ 35M.

Other meter models available upon request in single- and multi-unit enclosed versions.

Product Selection

Meter Subpanel Assembly

Description	Catalog Number
Meter subpanel assembly for PXM 2000 and IQ 150/250/260 Meters	PXM2K-MSPA-A
Meter subpanel assembly with CPT for PXM 2000 and IQ 150/250/260 Meters	PXM2K-MSPA-B

Technical Data and Specifications

Enclosed Meters

Description	Specification
Enclosure rating	NEMA 12, 3R, 4X
Enclosure operating temperature	-20°C to +40°C Note: Temperature range of meter is -20 °C to +70 °C. If applied outside, proper precautions should be taken to avoid exceeding the maximum and minimum temperature ratings of the meter.
Dimensions	Single unit (IQ 150/250/260 and PXM 2000): NEMA 12 (8.00 W x 16.30 H x 10.40 D inches), NEMA 3R/4X (8.00 W x 16.30 H x 9.60 D inches) Single MME (PXBCM): NEMA 12 (16.00 W x 16.00 H x 8.00 D inches) NEMA 3R/4X (20.00 W x 16.00 H x 12.00 D inches) Two MME (PXBCM): NEMA 12 (16.00 W x 24.00 H x 8.00 D inches) NEMA 3R/4X (20.00 W x 24.00 H x 12.00 D inches) Single unit (PXMP): NEMA 12/3R/4X (24.00 W x 30.00 H x 12.00 D inches) Single unit (PXM 4000/6000/8000): NEMA 12 (20.00 W x 24.00 H x 14.10 D inches) NEMA 3R/4X (20.20 W x 24.00 H x 13.90 D inches) Multi unit: NEMA 12 (13.00 W x 30.00 H x 15.20 D inches) NEMA 3R (13.20 W x 30.10 H x 14.60 D inches) NEMA 4X (13.00 W x 30.00 H x 14.00 D inches)
Meters	Single unit: IQ 150, IQ 250/260, PXM 2000/4000/6000/8000 and PXMP models Multi unit: IQ 35M, IQ 150 and IQ 250/26060
Communications (multi unit only)	Power Xpert Gateway 900
Control voltage	120–600 V (PXMP)—power supply required 100–277 Vac L:N (PXBCM)—no CPT required Up to 240 V (IQ 35M/150/250/260 and PXM 2000/4000/6000/8000)—no CPT required Greater than 240 V (IQ 150/250/260 and PXM 2000)—CPT required Separate source control—no CPT required
Basic model	Fusible disconnect—primary voltage Shorting block(s)—not required for IQ 35M or PXMP Ground terminal block Neutral terminal block Eight-point terminal block(s) for input/output modules for IQ 250/260 and PXM 2000
Wiring	Wired for three-phase, four-wire applications. Three-phase, three-wire applications—will need to change the wiring for both the voltage and the current per the wiring diagram in the meter instruction manual.
Certifications	UL® 508A and cUL®
Source control	No separate source control voltage required for applications below 240 Vac (except PXMP)
Prewired	Prewired current transformer, shorting terminal block(s), neutral, ground, voltage, control power, fusible disconnect and input/output terminal block(s)
Latch	Padlocking latch provision
Optional features	Control power transformer—single unit: 50 VA (IQ 150/250/260) and 150 VA (PXM 4000/6000/8000); multi unit: 250 VA control power supply for meter where monitored voltage is 480 Vac (IQ 150/250/260 and PXM 2000/4000/6000/8000)

Note: Specifications are subject to change without notice and represent the maximum capabilities of the product with all options installed. This is not a complete feature list. Features and functionality may vary depending on selected options, firmware version and product model. Please refer to the technical data sheet and the user manual for detailed specifications.

Wiring Diagrams

Single Unit Enclosure—200/240 Vac 50/60 Hz, Three-Phase, Four-Wire System with IQ 150/250/260 or PXM 2000 Meter

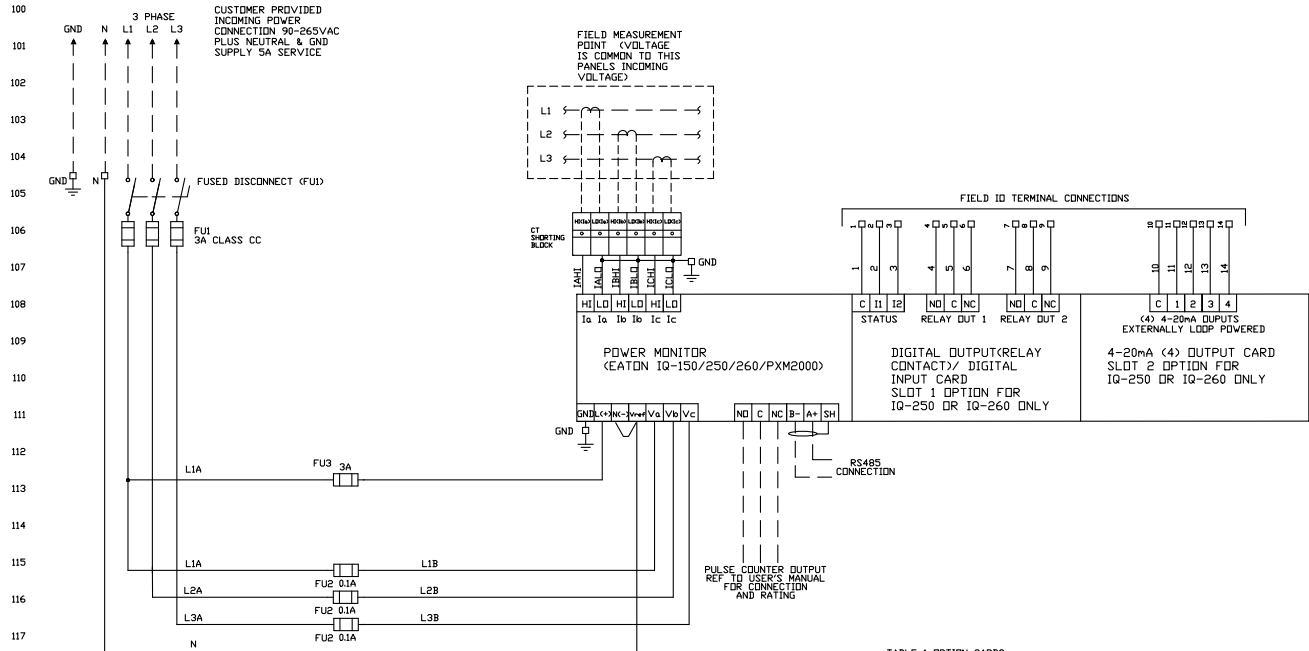

NOTE 1: DASH LINES ARE CUSTOMER CONNECTIONS.
 NOTE 2: STANDARD APPLICATION ASSUMED TO BE 300-240V 3 PHASE 4 WIRE SYSTEMS. FOR ALTERNATE SYSTEMS, VOLTAGES AND CT CONFIGURATIONS, PLEASE SEE CHAPTER 4 OF THE INSTALLATION AND OPERATION MANUAL FOR THE RESPECTIVE METER PROVIDED IN THE ENCLOSURE.

TABLE 1 OPTION CARDS

PWR MONITOR METER	RS485 MODBUS PULSE COUNTER	ANALOG OUTPUT CARD	DIG ID CARD	ETHERNET
IQ100 SERIES	OPTION	N/A	N/A	OPTION
IQ250/260 SERIES	STANDARD	OPTION	OPTION	N/A
PXM2000 SERIES	STANDARD	OPTION*	OPTION*	STANDARD

* ANALOG OUTPUT OPTION CARD AND DIGITAL ID CARD ARE MUTUALLY EXCLUSIVE FOR THE PXM2000 SERIES

Single Unit Enclosure—480 Vac 50/60 Hz, Three-Phase, Four-Wire System with IQ 150/250/260 or PXM 2000 Meter

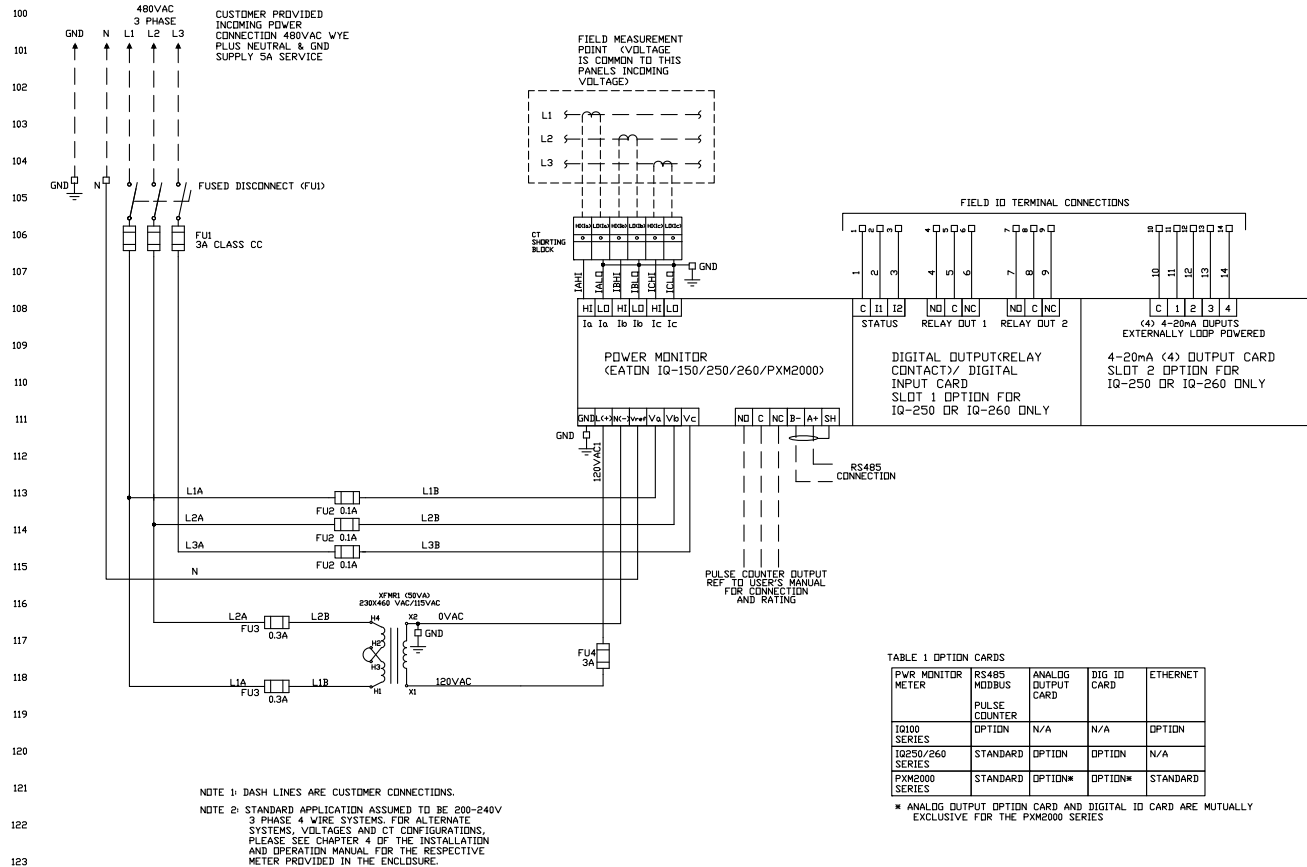

TABLE 1 OPTION CARDS

PWR MONITOR METER	RS485 MODBUS PULSE COUNTER	ANALOG OUTPUT CARD	DIG ID CARD	ETHERNET
IQ100 SERIES	OPTION	N/A	N/A	OPTION
IQ250/260 SERIES	STANDARD	OPTION	OPTION	N/A
PXM2000 SERIES	STANDARD	OPTION*	OPTION*	STANDARD

* ANALOG OUTPUT OPTION CARD AND DIGITAL ID CARD ARE MUTUALLY EXCLUSIVE FOR THE PXM2000 SERIES

9.2

Metering Devices, Protective Relays, Software and Connectivity

Metering Devices

Multi Unit Enclosure—200–240 Vac 50/60 Hz, Three-Phase, Four-Wire System with IQ 35M Meters

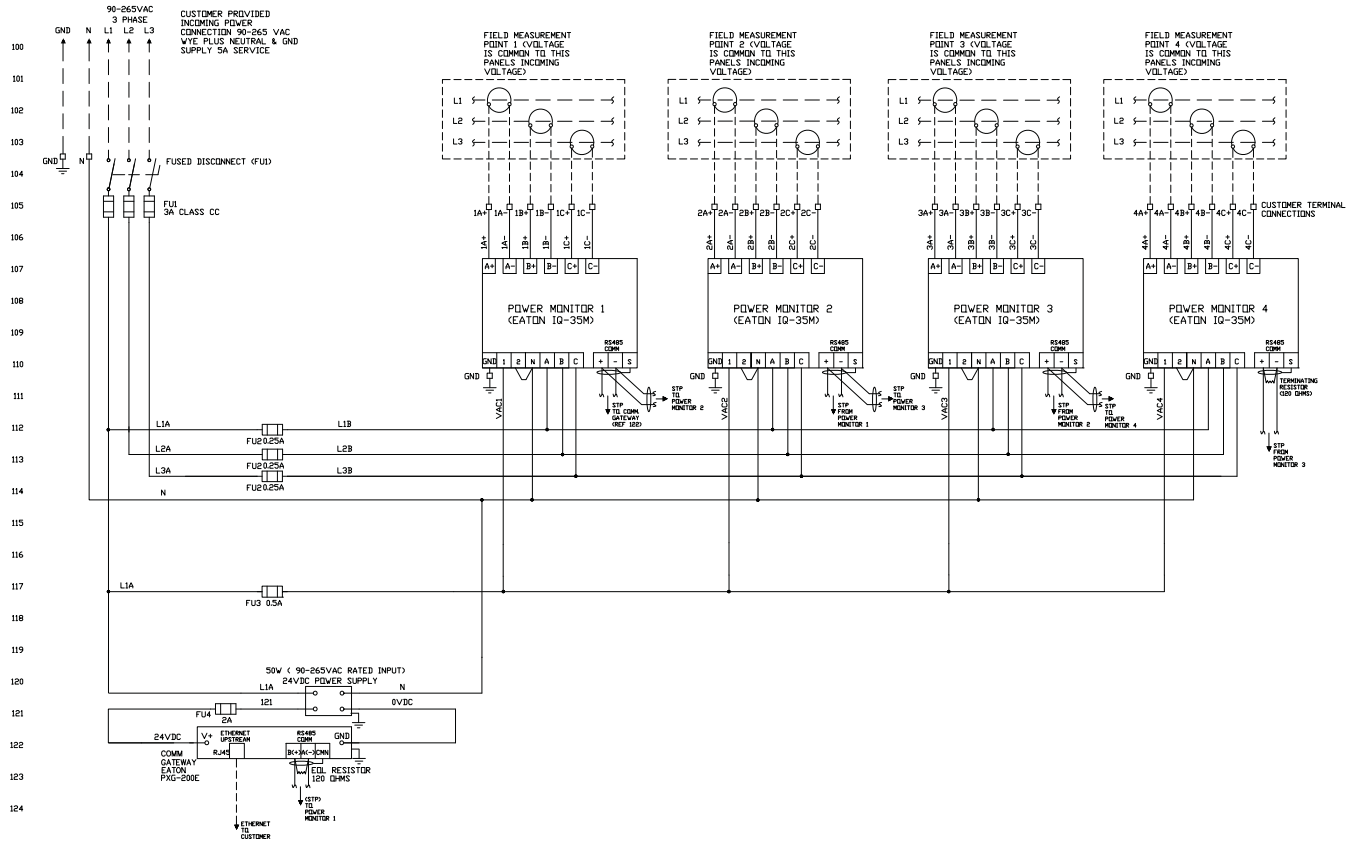

Multi Unit Enclosure—480 Vac 50/60 Hz, Three-Phase, Four-Wire System with IQ 150/250/260 Meters

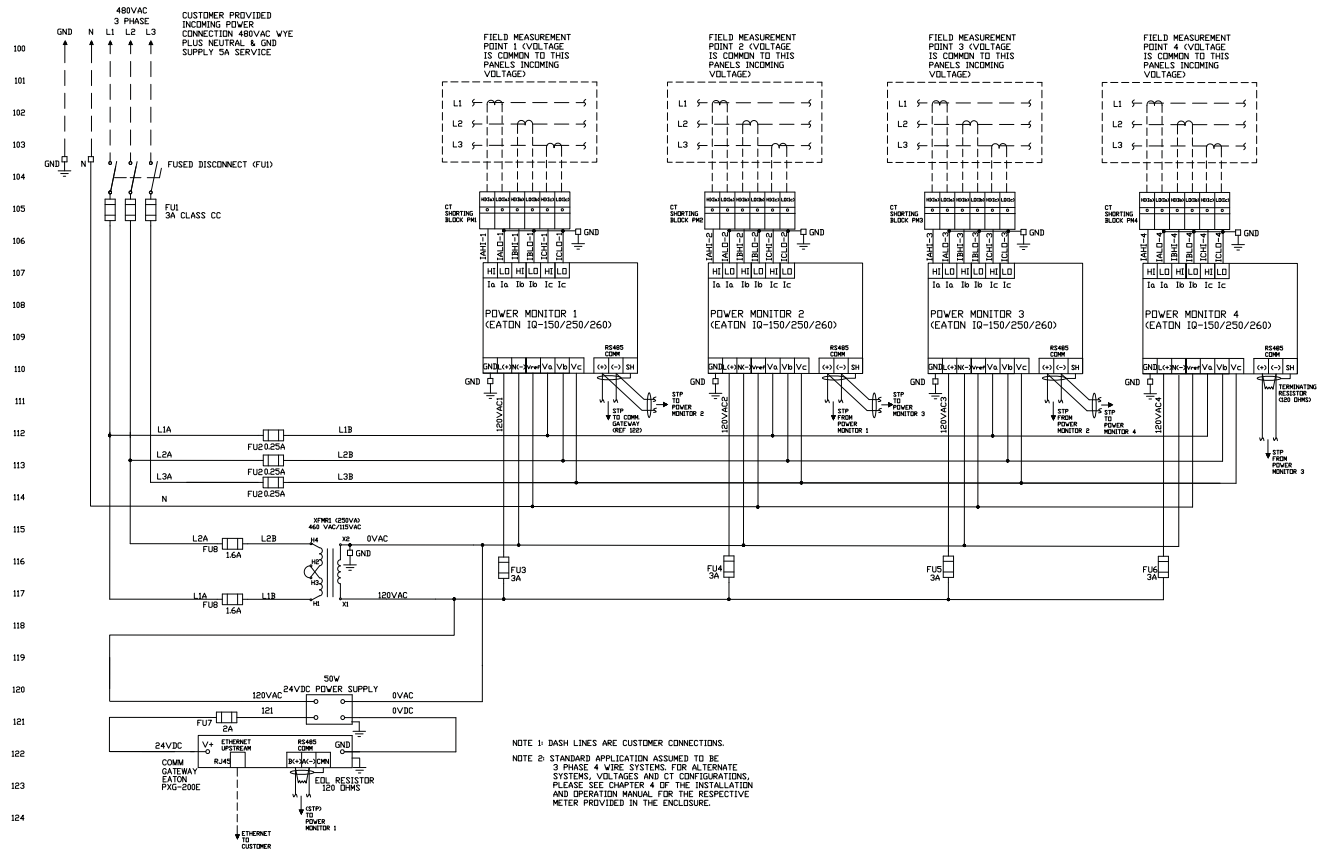

Single Unit Enclosure—120–240 Vac 50/60 Hz, Three-Wire System with PXMP Meter

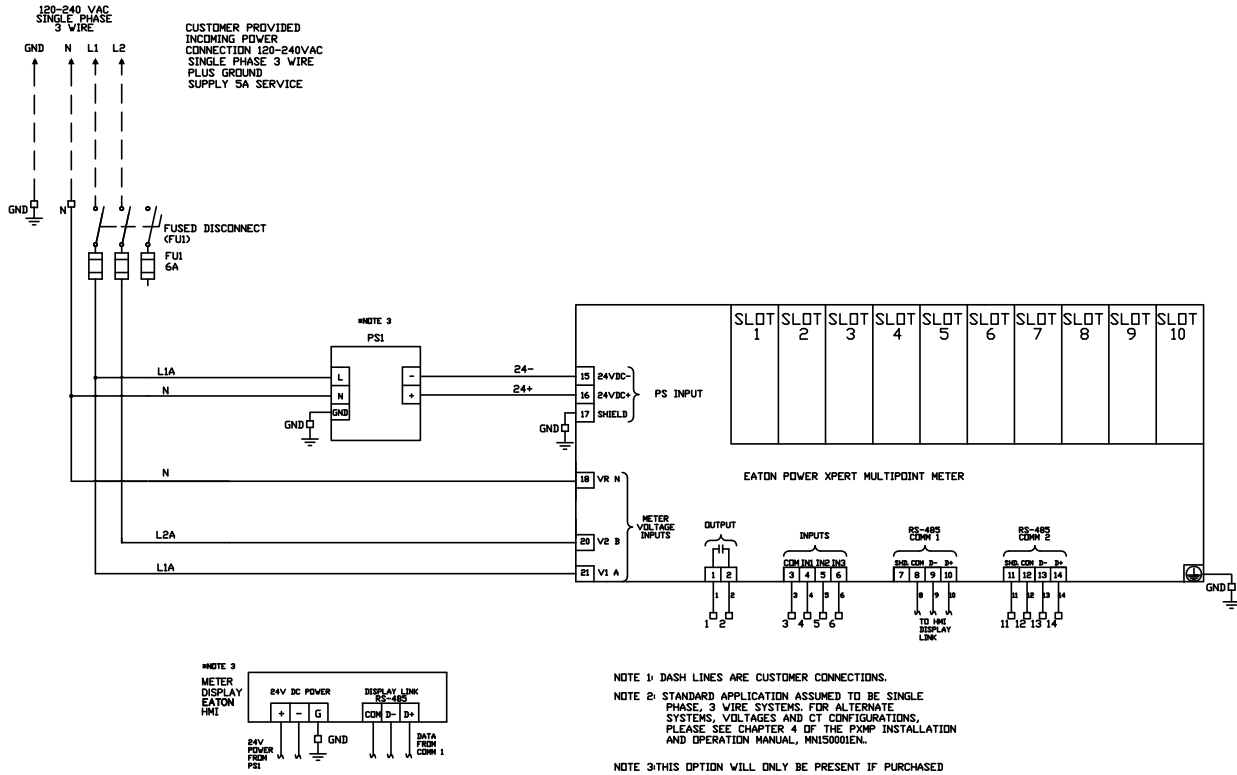

Single Unit Enclosure – 120–240 Vac 50/60 Hz, Three-Phase, Four-Wire Wye System with PXMP Meter

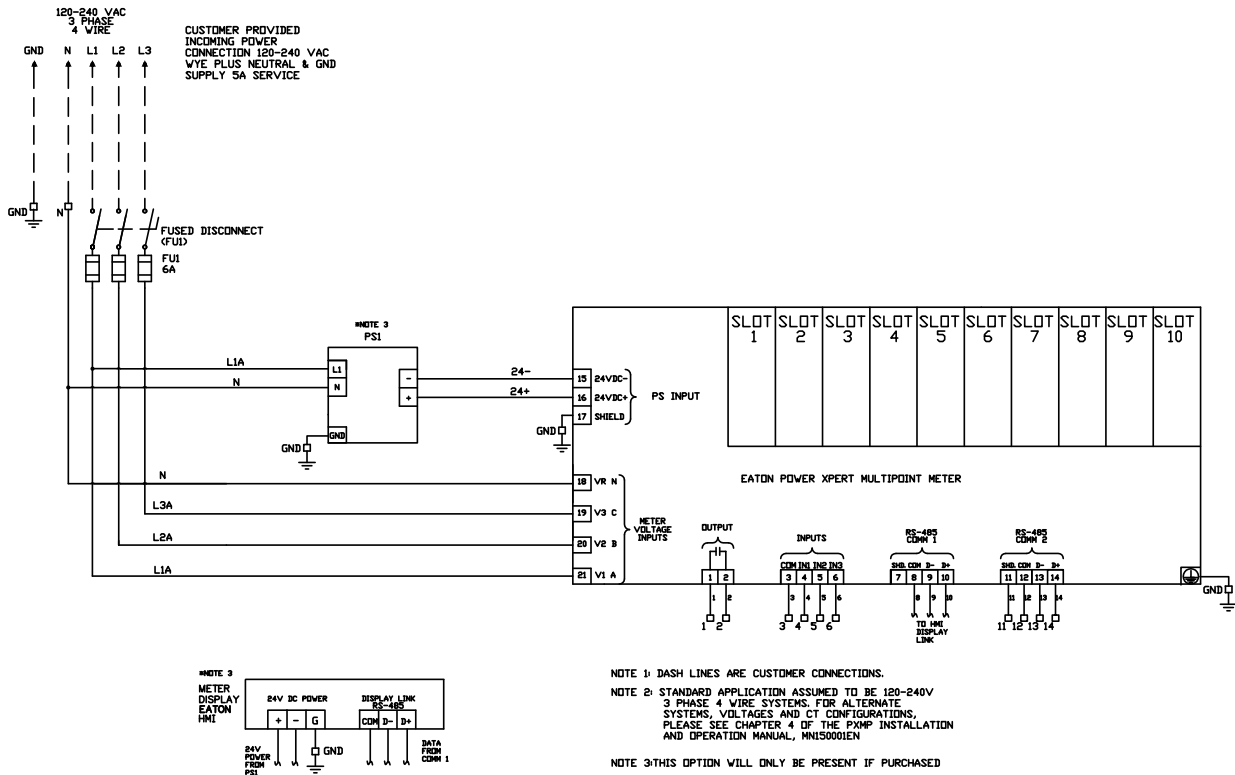

Single Unit Enclosure—480–600 Vac 50/60 Hz, Three-Phase, Four-Wire Wye System with PXMP Meter

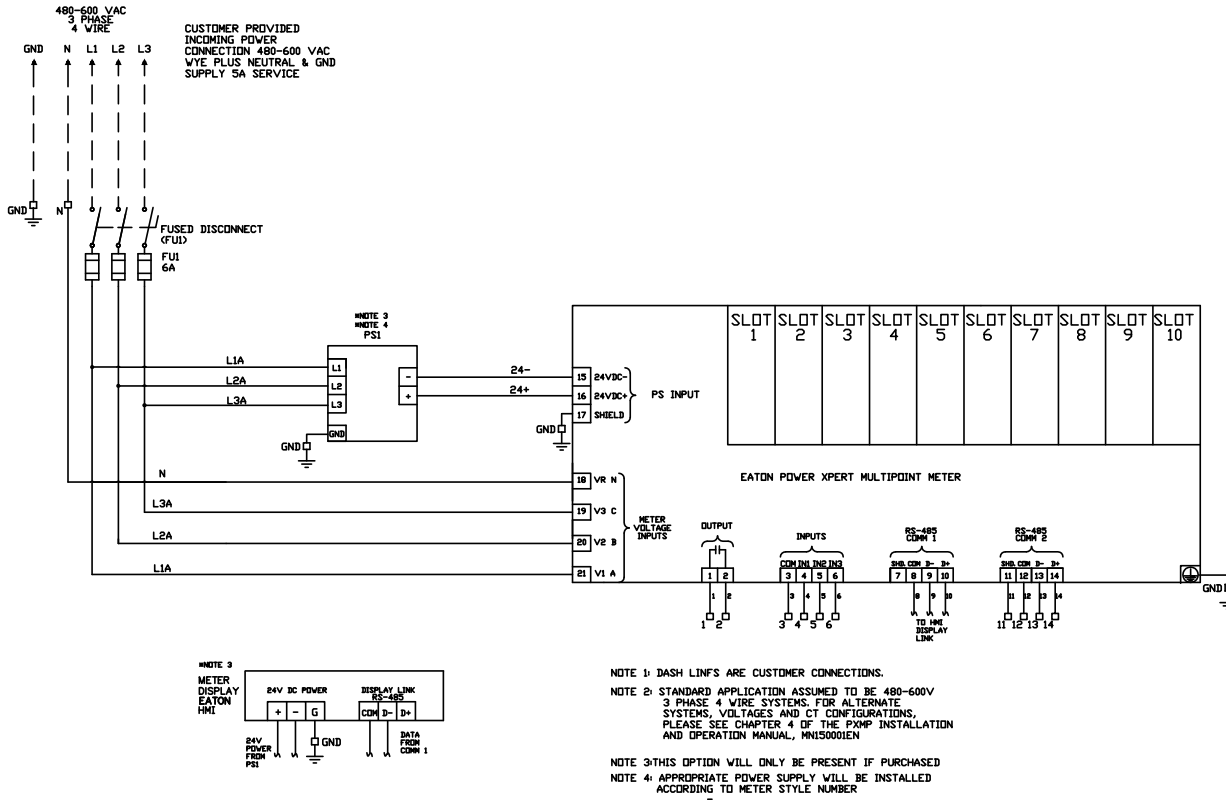

Single Unit Enclosure—200–240 Vac 50/60 Hz, Three-Phase, Four-Wire System with PXM 4000/6000/8000 Meter

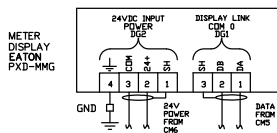
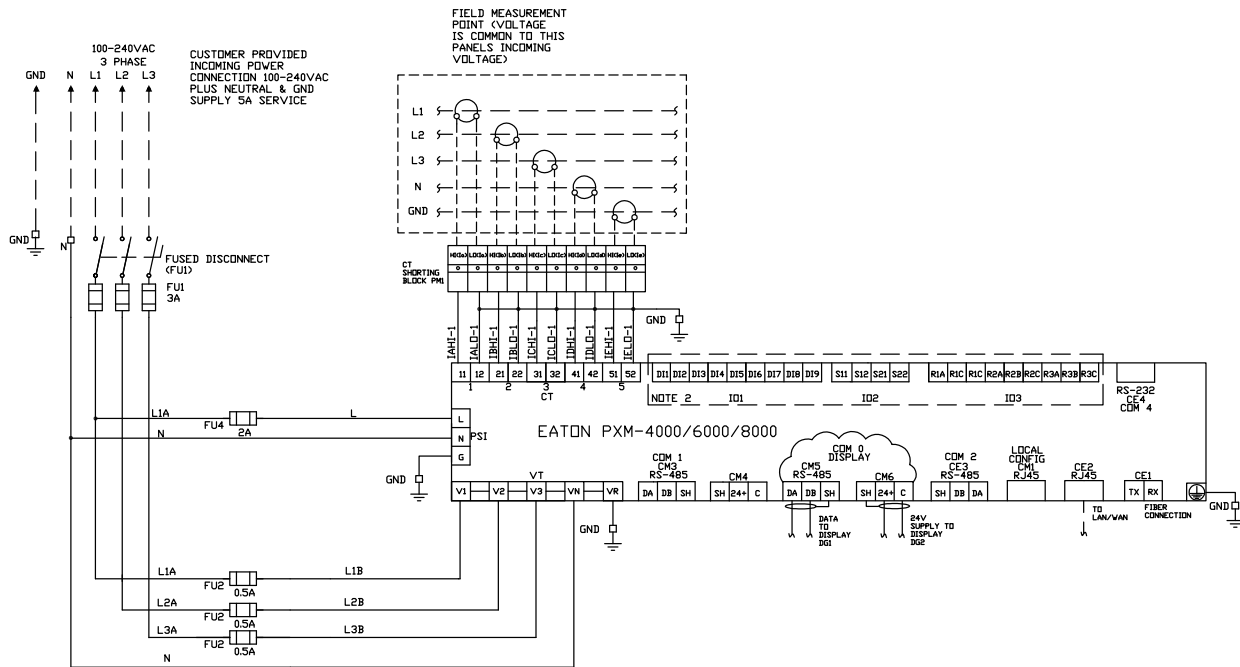

NOTE 1: DASH LINES ARE CUSTOMER CONNECTIONS.
NOTE 2: STANDARD APPLICATION ASSUMED TO BE 100-240VAC 3 PHASE 4 WIRE SYSTEMS. FOR ALTERNATE SYSTEMS, VOLTAGES AND CT CONFIGURATIONS, PLEASE SEE CHAPTER 4 OF THE INSTALLATION AND OPERATION MANUAL FOR THE RESPECTIVE METER PROVIDED IN THE ENCLOSURE.
NOTE 3: THIS OPTION WILL ONLY BE PRESENT IF PURCHASED

Single Unit Enclosure—480 Vac 50/60 Hz, Three-Phase, Four-Wire System with PXM 4000/6000/8000 Meter

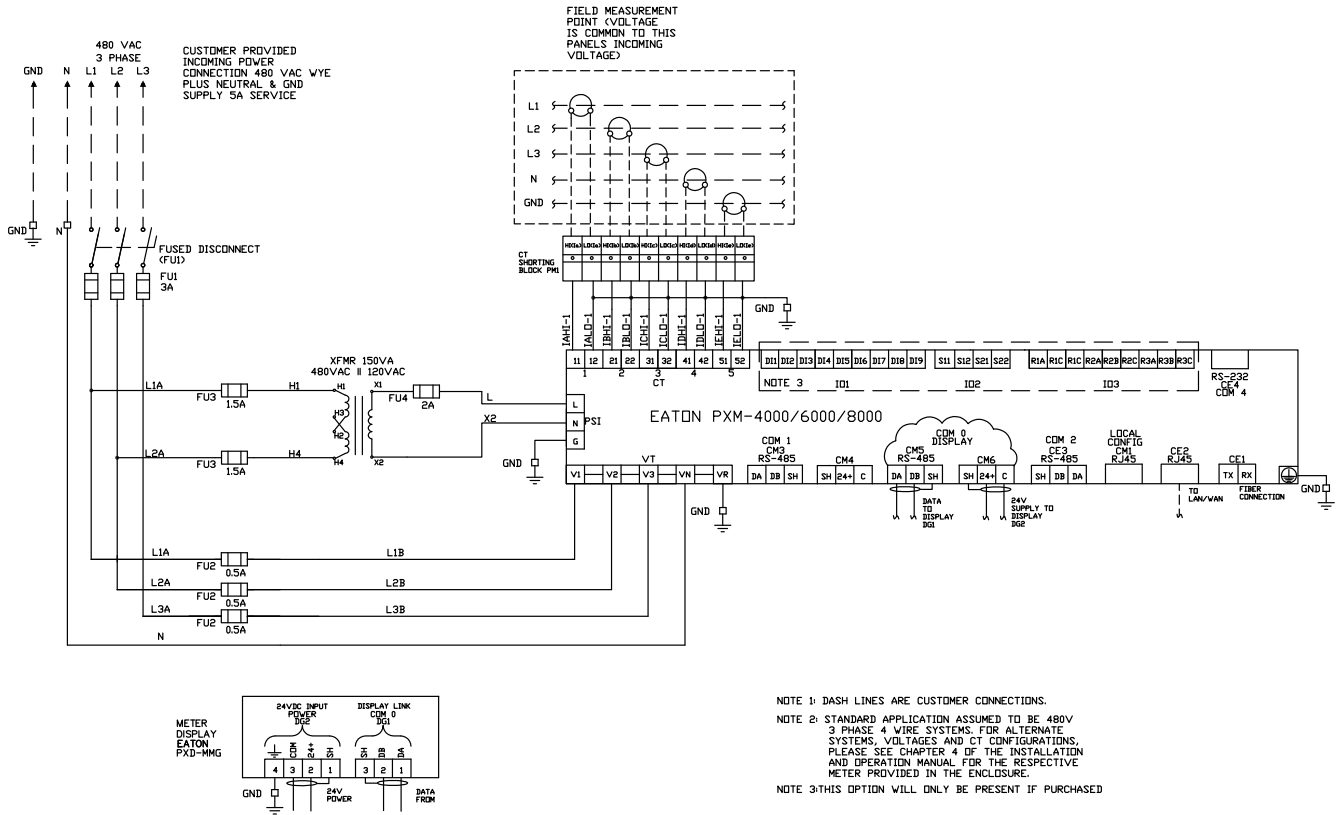

9.2

Metering Devices, Protective Relays, Software and Connectivity

Metering Devices

Dimensions

Approximate Dimensions in Inches (mm)

NEMA 12 Single Unit Enclosure

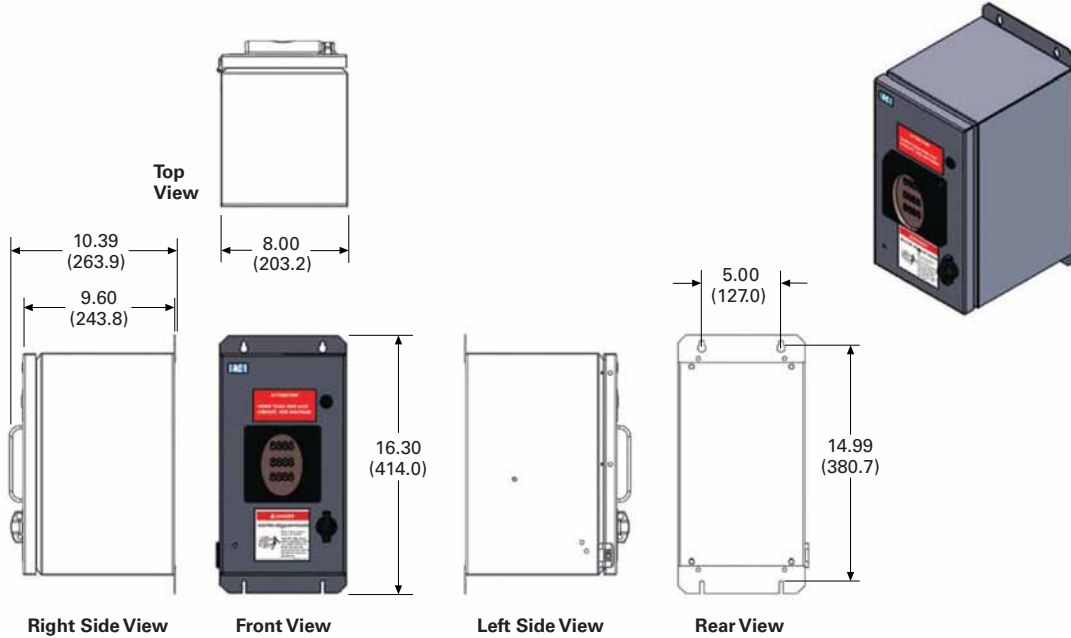

9

NEMA 12 Multi Unit Enclosure

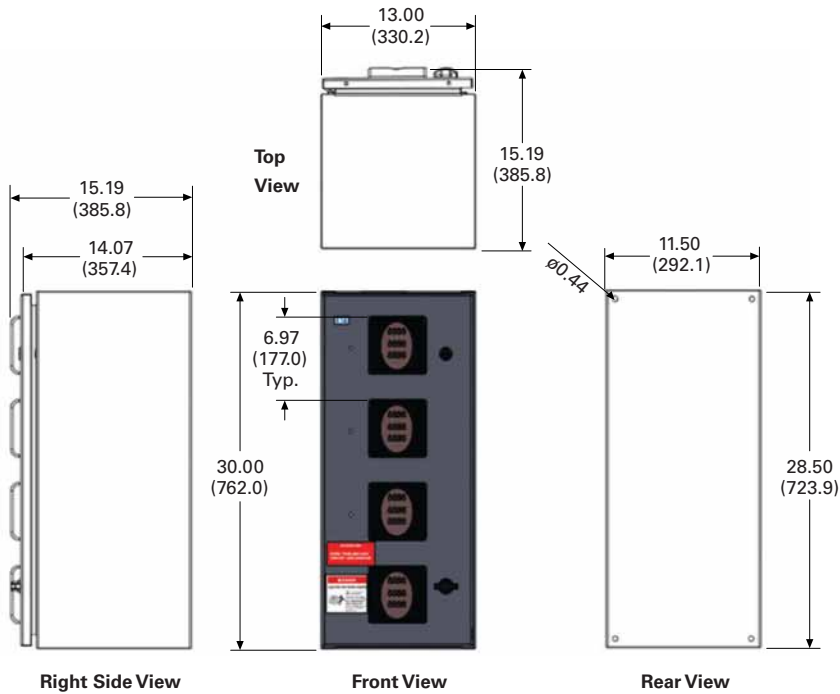

Approximate Dimensions in Inches (mm)

NEMA 12 PXM 4000/6000/8000 Enclosure

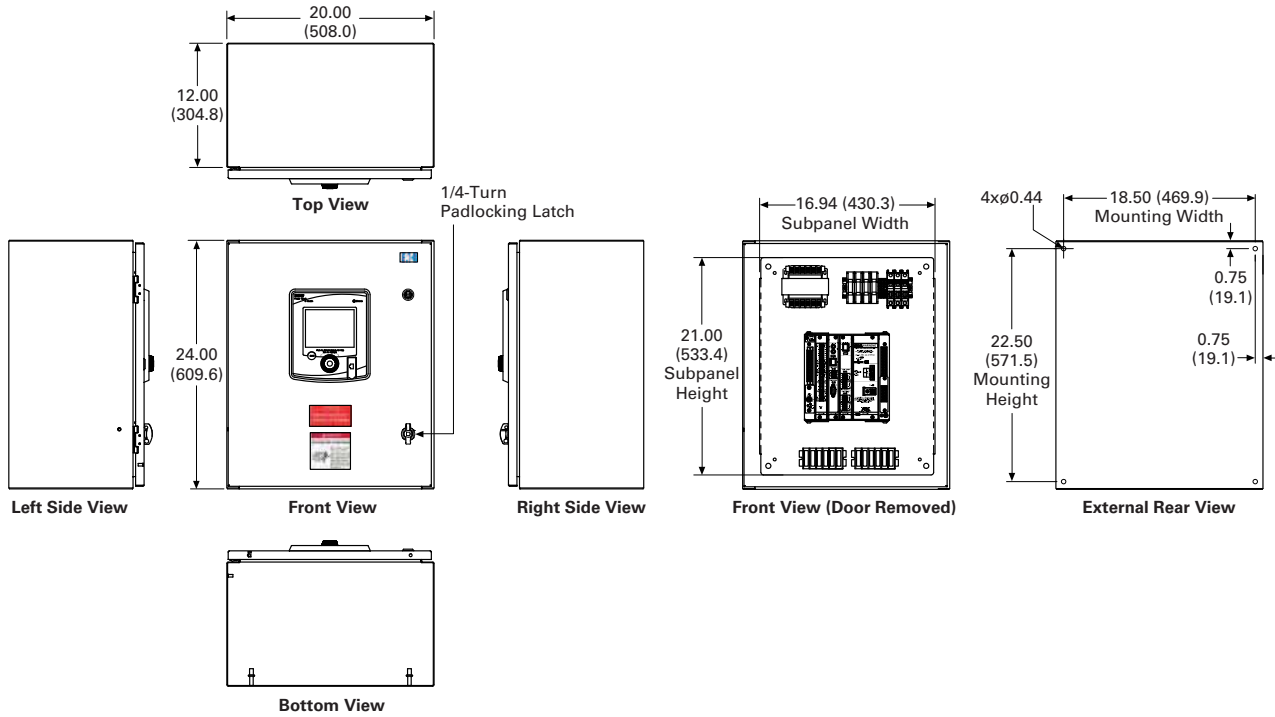

NEMA 12 PXMP Enclosure

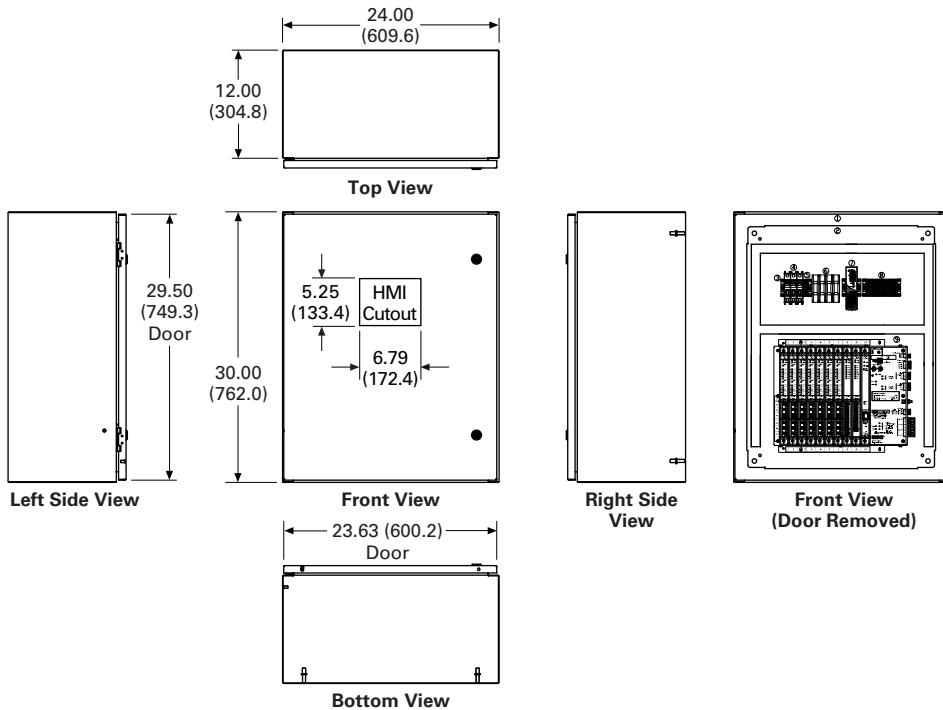

9.2

Metering Devices, Protective Relays, Software and Connectivity

Metering Devices

Approximate Dimensions in Inches (mm)

NEMA 3R/4X Single Unit Enclosure

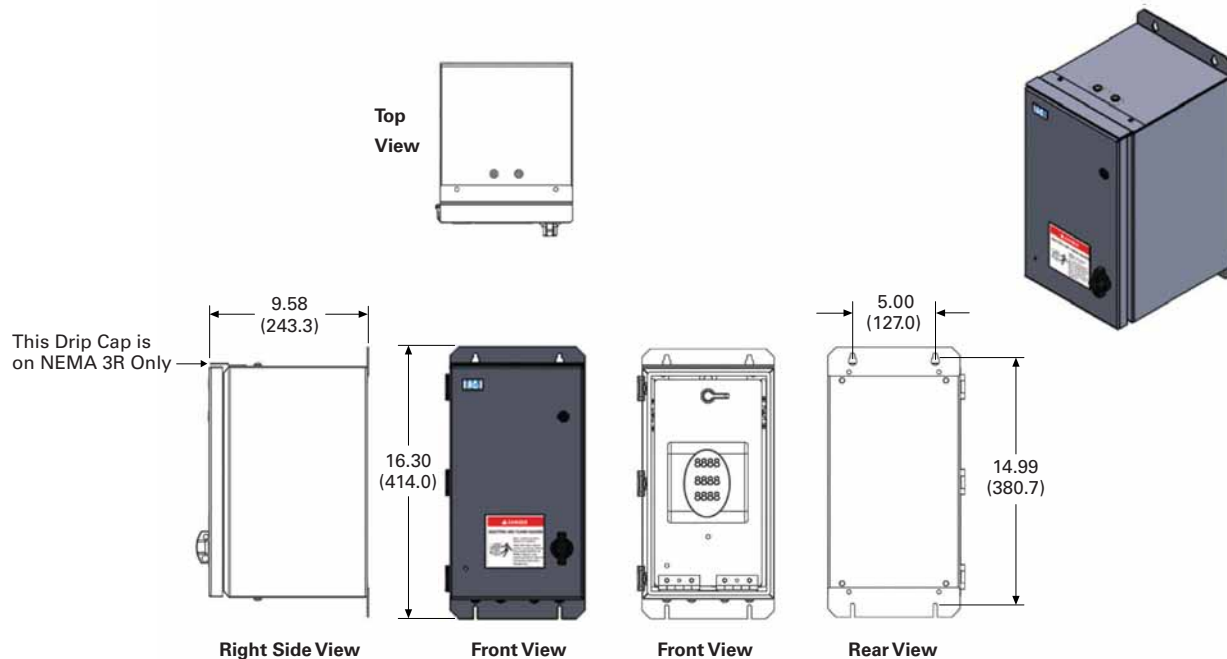

NEMA 3R/4X Multi Unit Enclosure

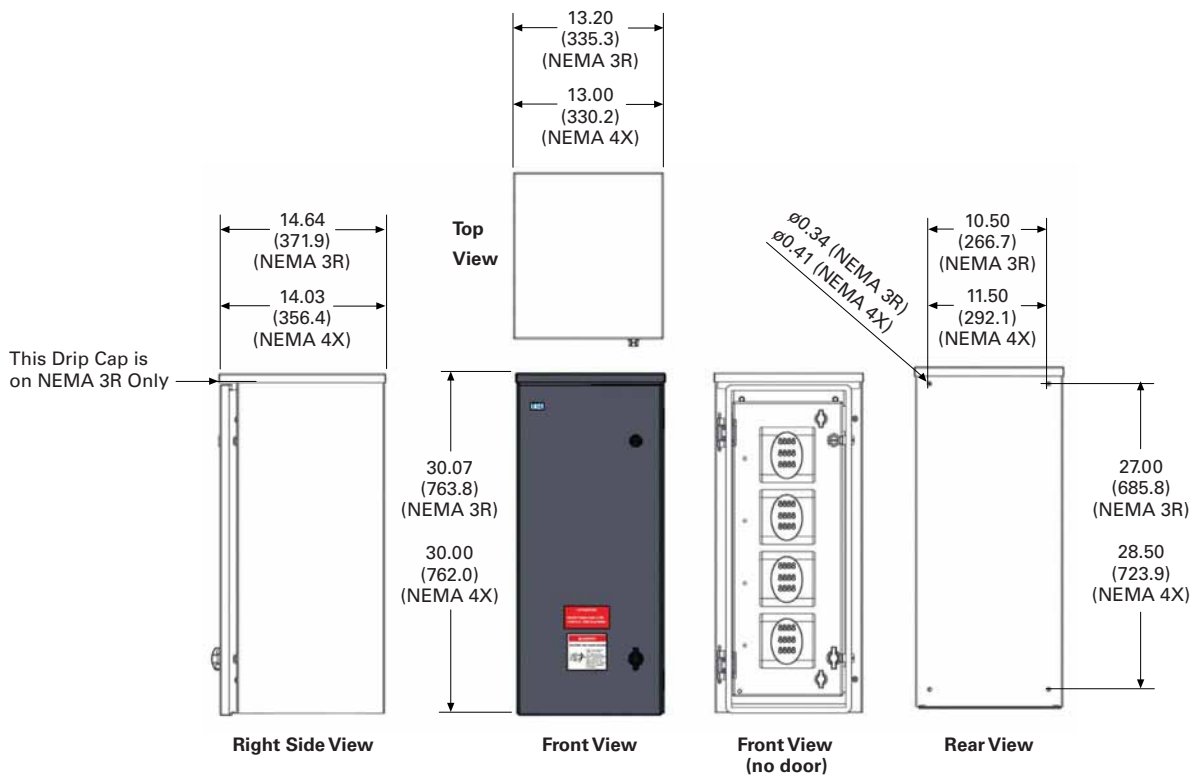

Approximate Dimensions in Inches (mm)

NEMA 3R PXM 4000/6000/8000 Unit Enclosure

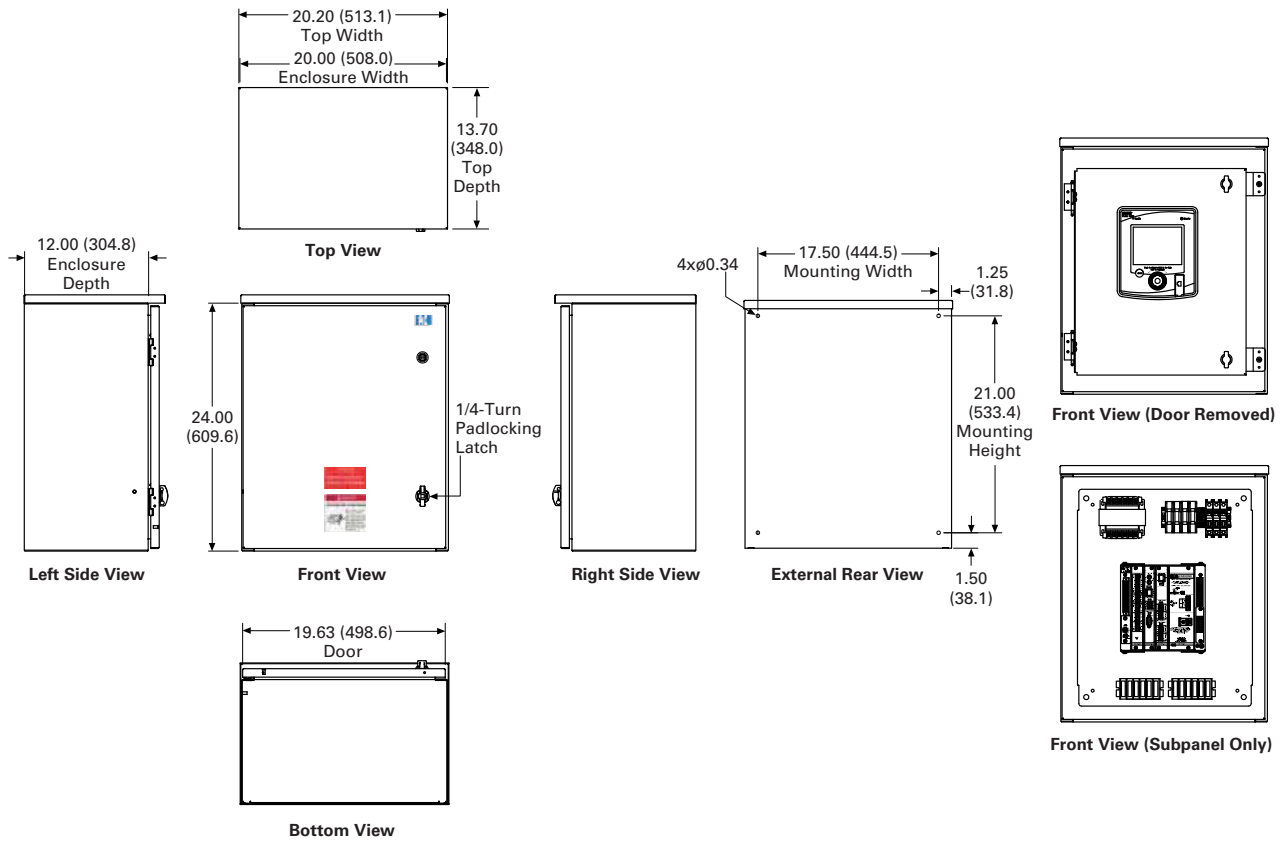

9.2

Metering Devices, Protective Relays, Software and Connectivity

Metering Devices

Approximate Dimensions in Inches (mm)

NEMA 4X PXM 4000/6000/8000 Unit Enclosure

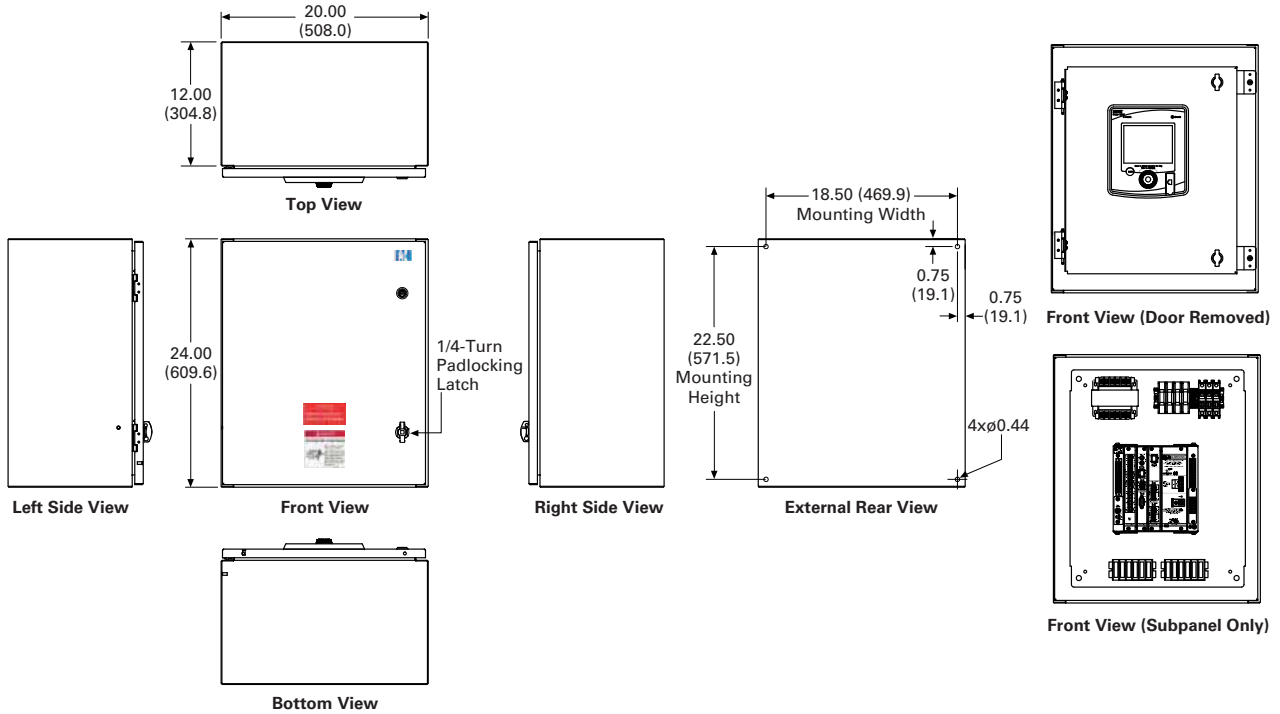

Approximate Dimensions in Inches (mm)

NEMA 3R PXMP Multi Unit Enclosure

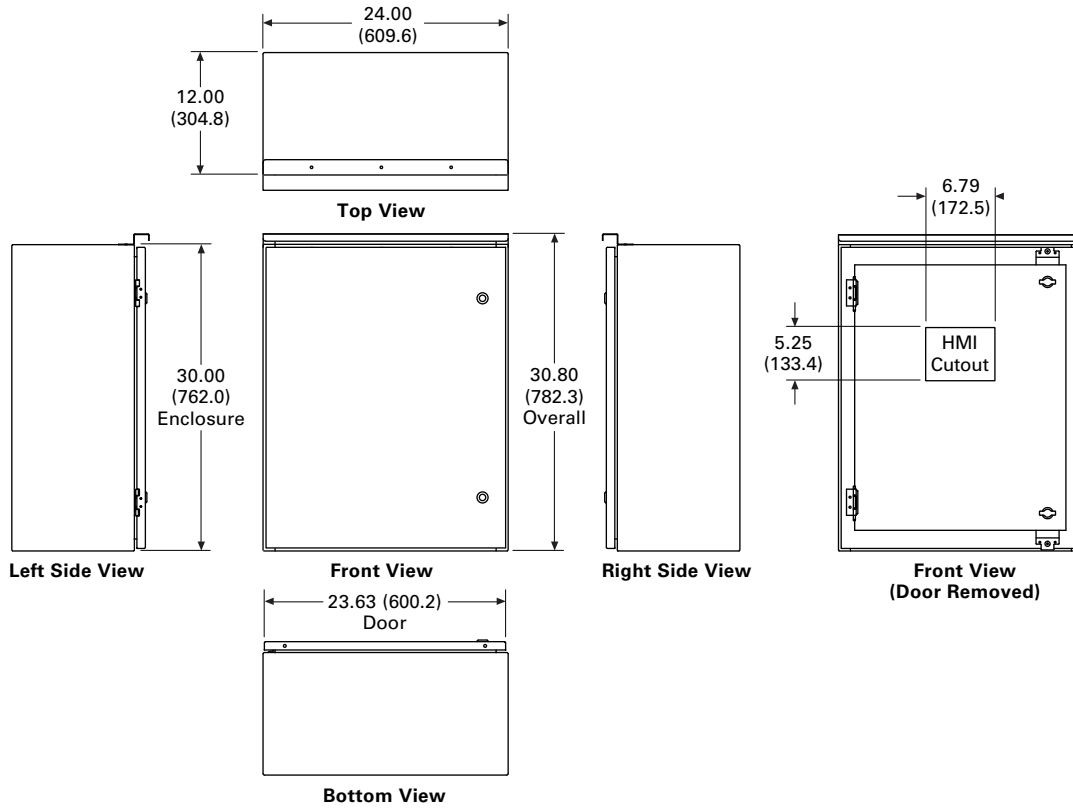

9.2

Metering Devices, Protective Relays, Software and Connectivity

Metering Devices

Approximate Dimensions in Inches (mm)

NEMA 4X PXMP Multi Unit Enclosure

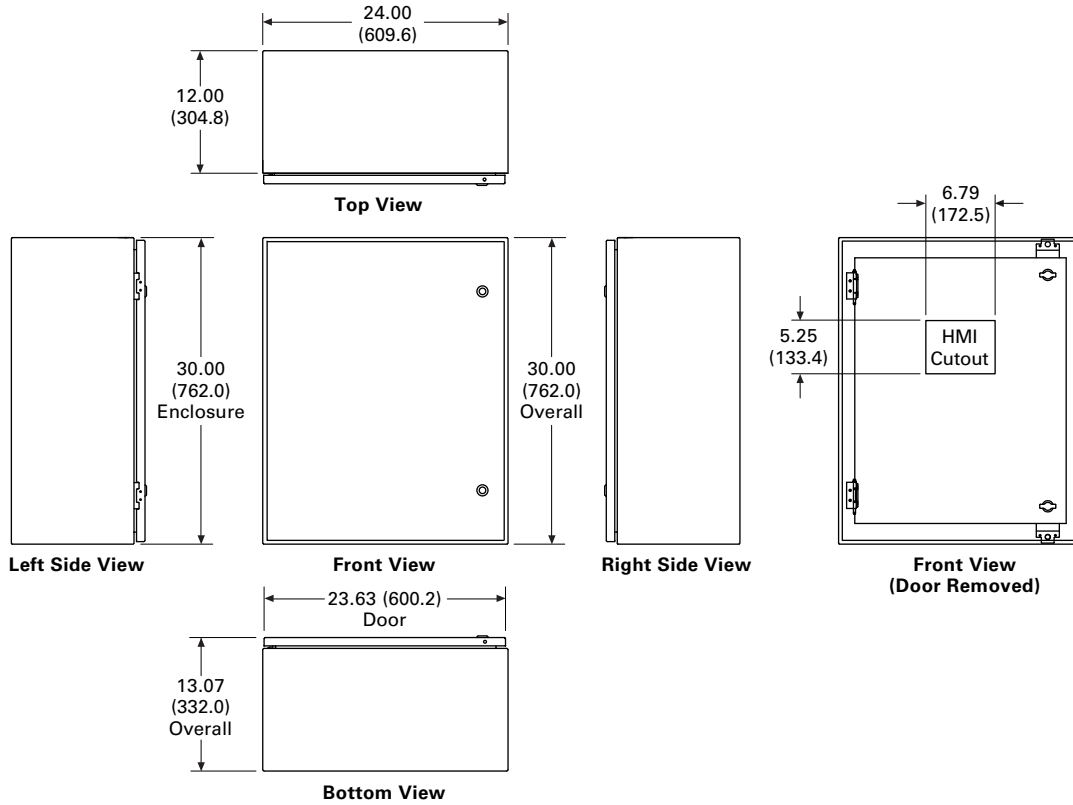

Contents

<i>Description</i>	<i>Page</i>
Product Selection Guide	
Digitrip 3000	V3-T9-123
EDR-3000 Feeder Protection	V3-T9-133
EDR-5000 Distribution Protection Relay	V3-T9-142
FP-5000 Feeder Protection	V3-T9-155
MP-3000 Motor Protection	V3-T9-163
MP-4000 Motor Protection	V3-T9-173
EMR-3000 Motor Protection Relay	V3-T9-179
EMR-4000 Motor Protection Relay	V3-T9-191
EMR-5000 Motor Protection Relay	V3-T9-204
ETR-4000 Transformer Protection Relay	V3-T9-216
ETR-5000 Transformer Protection Relay	V3-T9-228
EGR-5000 Generation Protection Relay	V3-T9-241
Ground Fault Relay	V3-T9-254
Universal RTD Module	V3-T9-257

Product Selection Guide

Protective Relay Selection Chart

Protection Functions

Description	IEEE Device Number	Feeder Protection				Motor Protection					Transformer Protection		Generator Protection
		DT-3000 V3-T9-123	EDR-3000 V3-T9-133	EDR-5000 V3-T9-142	FP-5000 V3-T9-155	MP-3000 V3-T9-163	MP-4000 V3-T9-173	EMR-3000 V3-T9-179	EMR-4000 V3-T9-191	EMR-5000 V3-T9-204	ETR-4000 V3-T9-123	ETR-5000 V3-T9-123	EGR-5000 V3-T9-241
Phase inst. OC	50	■	■	■	■	■	■	■	■	■	■	■	■
Phase TOC	51	■	■	■	■	■	■	■	■	■	■	■	■
Ground inst. OC (measured)	50G	■	■	■	■	■	■	■	■	■	■	■	■
Ground TOC (measured)	51G	■	■	■	■	■	■	■	■	■	■	■	■
Ground inst. OC (calculated)	50R		■	■	■			■	■	■	■	■	■
Ground TOC (calculated)	51R		■	■	■			■	■	■	■	■	■
No. of curves (ANSI/IEC/thermal)		11	11	11	10			11	11	11	11	11	11
Zone selective interlocking		■	■	■	■			■	■	■	■	■	■
Phase directional control ①	67			■	■				■	■		■	■
Ground directional control ①	67N			■	■				■	■		■	■
Phase voltage restrained OC	51VR			■	■				■	■		■	■
Undervoltage	27			■	■		■		■	■		■	■
Current unbalance	46		■	■	■	■	■	■	■	■		■	■

Note

① Directional elements are controlled by reverse, forward, or both directions.

Protection Functions, continued

Description	IEEE Device Number	Feeder Protection					Motor Protection					Transformer Protection		Generator Protection
		DT-3000	EDR-3000	EDR-5000	FP-5000	MP-3000	MP-4000	EMR-3000	EMR-4000	EMR-5000	ETR-4000	ETR-5000	EGR-5000	
		V3-T9-123	V3-T9-133	V3-T9-142	V3-T9-155	V3-T9-163	V3-T9-173	V3-T9-179	V3-T9-191	V3-T9-204	V3-T9-123	V3-T9-123	V3-T9-241	
Voltage unbalance	47		■	■		■			■	■		■	■	
Power factor	55		■	■		■			■	■			■	
Overvoltage	59		■	■		■			■	■		■	■	
Frequency (over/under)	81		■	■		■			■	■		■	■	
Rate of change of frequency	81R		■	■		■			■	■		■	■	
Vector surge	78V		■						■	■		■	■	
Forward/reverse power	32		■	■	■				■	■		■	■	
Forward/reverse VARs	32V		■						■	■		■	■	
Sync check	25		■	■									■	
Reclosing	79		■									■	■	
Ground overvoltage	59N		■										■	
Thermal overload ①	49					■	■	■	■	■	■	■	■	
Underload	37								■	■	■			
Locked rotor	49S/51					■	■	■	■	■				
Jam/stall	51R					■	■	■	■	■				
Incomplete sequence	48					■	■	■	■	■				
Number of starts limit						■	■	■	■	■				
Starts per hour	66					■	■	■	■	■				
Time between starts						■	■	■	■	■				
Long acceleration time						■	■	■	■	■				
Emergency override						■	■	■	■	■				
Broken rotor bar detection									■	■				
Loss of potential	60LOP			■	■							■	■	
Current transformer supervision			■	■					■	■	■	■	■	
Cold load pickup			■	■	■				■	■	■	■	■	
Switch on to fault			■	■								■	■	
Breaker failure	50BF		■	■	■				■	■	■	■	■	
2nd harmonic restraint											■	■		
4th harmonic restraint											■	■		
5th harmonic restraint											■	■		
Differential	87									■	■	■	■	
Ground differential	87GD										■	■	■	
Trip lock out	86	■	■	■	■	■	■	■	■	■	■	■	■	
Negative sequence current	51Q										■	■	■	
External protection			■	■		■	■	■	■	■	■	■	■	
Overexcitation (Volts/Hz)	24											■	■	
Loss of field	40												■	
Low voltage ride-through	27T			■								■	■	
Reactive power and undervoltage	27Q			■								■	■	
Inadvertent energization	50/27												■	

Note

① When communicating to an external UR TD device.

Control Functions

Description	IEEE Device Number	Feeder Protection				Motor Protection					Transformer Protection		Generator Protection
		DT-3000 V3-T9-123	EDR-3000 V3-T9-133	EDR-5000 V3-T9-142	FP-5000 V3-T9-155	MP-3000 V3-T9-163	MP-4000 V3-T9-173	EMR-3000 V3-T9-179	EMR-4000 V3-T9-191	EMR-5000 V3-T9-204	ETR-4000 V3-T9-123	ETR-5000 V3-T9-123	EGR-5000 V3-T9-241
Remote open/close		■	■	■	■	Open only	Open only	■	■	■	■	■	■
Programmable I/O		■	■	■	■	■	■	■	■	■	■	■	■
Digital inputs		1	4 or 8	8	8	2	2	4	8	8 or 16	8	8	8 or 16
Relay outputs		2	3 or 5	10	6	4	4	3	4	8	8	8	8
Supervisory/alarm output		1	1	1	1	1	1	1	1	1	1	1	1
Programmable logic control			■	■	■			■	■	■	■	■	■
Multiple settings groups			4	4	4			4	4	4	4	4	4
Adaptive parameters			■	■				■	■	■	■	■	■
Reduced voltage starting						■	■	■	■	■			
Analog outputs						1	1		4	Option for 2		Option for 2	Option for 2
Analog inputs										Option for 2		Option for 2	Option for 2

Metering Functions

Description	IEEE Device Number	Feeder Protection				Motor Protection					Transformer Protection	Generator Protection	
		DT-3000	EDR-3000	EDR-5000	FP-5000	MP-3000	MP-4000	EMR-3000	EMR-4000	EMR-5000	ETR-4000	ETR-5000	EGR-5000
		V3-T9-123	V3-T9-133	V3-T9-142	V3-T9-155	V3-T9-163	V3-T9-173	V3-T9-179	V3-T9-191	V3-T9-204	V3-T9-123	V3-T9-123	V3-T9-241
Amperes		■	■	■	■		■	■	■	■	■	■	■
Ampere demand		■	■	■	■		■	■	■	■	■	■	■
Voltage (L-N and L-L)				■	■		■		■	■		■	■
Phase angle			■	■	■		■	■	■	■		■	■
Pos., neg. and zero sequence			■	■	■		■	■	■	■		■	■
Watts				■	■		■		■	■		■	■
Watt demand				■	■		■		■	■		■	■
Watt-hour				■	■		■		■	■		■	■
VARs				■	■		■		■	■		■	■
VAR demand				■	■		■		■	■		■	■
VAR-hour				■	■		■		■	■		■	■
VA				■	■		■		■	■		■	■
VA Demand				■	■		■		■	■		■	■
VA-hour				■	■		■		■	■		■	■
Frequency				■	■		■		■	■		■	■
Minimum/maximum recording			■	■	■	Max. only	Max. only	■	■	■	■	■	■
Current unbalance			■	■		■	■	■	■	■	■	■	■
Voltage unbalance				■			■		■	■		■	■
Power factor				■	■		■		■	■		■	■
Sync values				■									■
Differential currents										■	■	■	■
2nd, 4th, 5th harmonic currents											■	■	
3rd harmonic voltage													■
THD current			■	■	■		■	■	■	■	■	■	■
THD voltage				■	■		■		■	■		■	■
Volt/Hertz									■	■		■	■
Thermal capacity								■	■	■			■
Generator hours of operation													■

Monitoring Functions

Description	IEEE Device Number	Feeder Protection				Motor Protection					Transformer Protection		Generator Protection
		DT-3000	EDR-3000	EDR-5000	FP-5000	MP-3000	MP-4000	EMR-3000	EMR-4000	EMR-5000	ETR-4000	ETR-5000	EGR-5000
		V3-T9-123	V3-T9-133	V3-T9-142	V3-T9-155	V3-T9-163	V3-T9-173	V3-T9-179	V3-T9-191	V3-T9-204	V3-T9-123	V3-T9-123	V3-T9-241
Trip circuit monitor	74	■	■	■			■	■	■	■	■	■	■
Breaker wear		■	■	■			■	■	■	■	■	■	■
Fault recorder		■	■	■			■	■	■	■	■	■	■
Waveform recorder		■	■	■			■	■	■	■	■	■	■
Sequence of events recorder		■	■	■	■	■	■	■	■	■	■	■	■
Trend recorder (load profile)		■	■	■			■	■	■	■	■	■	■
Clock		■	■	■	■	■	■	■	■	■	■	■	■
Time synchronization		■	■				■	■	■	■	■	■	■
RTD temperature ①						■	■	■	■	■	■	■	■
Hottest RTD ①						■	■	■	■	■	■	■	■

Communications

Description	IEEE Device Number	Feeder Protection				Motor Protection					Transformer Protection		Generator Protection
		DT-3000	EDR-3000	EDR-5000	FP-5000	MP-3000	MP-4000	EMR-3000	EMR-4000	EMR-5000	ETR-4000	ETR-5000	EGR-5000
		V3-T9-123	V3-T9-133	V3-T9-142	V3-T9-155	V3-T9-163	V3-T9-173	V3-T9-179	V3-T9-191	V3-T9-204	V3-T9-123	V3-T9-123	V3-T9-241
Front access interface													
Local human machine interface		■	■	■	■	■	■	■	■	■	■	■	■
RS-232		■	■	■			■	■	■	■	■	■	■
USB			②	②				②	②	②	②	②	②
Rear communication port interface													
RS-485		■	Option	Option	■			Option	Option	Option	Option	Option	Option
Ethernet copper (RJ45)			Option	Option				Option	Option	Option	Option	Option	Option
Fiber optic ST (note)			②	②				②	②	②	②	②	②
Fiber optic LC (note)			②	②				②	②	②	②	②	②
Protocol													
INCOM		■			Option	Option	Option						
Modbus-RTU		■	Option	Option	Option	Option	Option	Option	Option	Option	Option	Option	Option
Modbus-TCP			Option	Option				Option	Option	Option	Option	Option	Option
IEC 61850			Option	Option				Option	Option	Option	Option	Option	Option
DNP 3.0 (note)			②	②				②	②	②	②	②	②
PROFIBUS (note)			②	②				②	②	②	②	②	②
IRIG-B			Option	■				■	■	■	■	■	■
SNTP			Option	Option				Option	Option	Option	Option	Option	Option

Notes

- ① When communicating to an external URTD device.
- ② Option available beginning in late 2015.

Construction

Description	IEEE Device Number	Feeder Protection			Motor Protection						Transformer Protection		Generator Protection
		DT-3000 V3-T9-123	EDR-3000 V3-T9-133	EDR-5000 V3-T9-142	FP-5000 V3-T9-155	MP-3000 V3-T9-163	MP-4000 V3-T9-173	EMR-3000 V3-T9-179	EMR-4000 V3-T9-191	EMR-5000 V3-T9-204	ETR-4000 V3-T9-123	ETR-5000 V3-T9-123	EGR-5000 V3-T9-241
Panel mount case		■	Semi-flush or projected	Semi-flush or projected	■	■	■	Semi-flush or projected	Semi-flush or projected	Semi-flush or projected	Semi-flush or projected	Semi-flush or projected	Semi-flush or projected
Drawout case	Option	Removable terminals	Removable terminals	Removable terminals	Option	Option	Option	Removable terminals	Removable terminals	Removable terminals	Removable terminals	Removable terminals	Removable terminals
Self-shorting CT terminals		■	■					■	■	■	■	■	■
Operating temperature range	-30 to +55 °C	-40 to +60 °C	-40 to +60 °C	-40 to +60 °C	-40 to +60 °C	-20 to +60 °C	-20 to +60 °C	-40 to +60 °C	-40 to +60 °C	-40 to +60 °C	-40 to +60 °C	-40 to +60 °C	-40 to +60 °C
Power supply range (Vac)	120–240 Vac	40–250 Vac	40–250 Vac	48–125 Vdc	90–264 Vac	90–264 Vac	40–250 Vac	40–250 Vac	40–250 Vac	40–250 Vac	40–250 Vac	40–250 Vac	40–250 Vac
Power supply range (Vdc)	24–250 Vdc	19–300 Vdc	19–300 Vdc	48–125 Vdc			19–300 Vdc	19–300 Vdc	19–300 Vdc	19–300 Vdc	19–300 Vdc	19–300 Vdc	19–300 Vdc
AC current inputs	■	■	■	■	■	■	■	■	■	■	■	■	■
AC voltage inputs			■	■		■		■	■			■	■
Wye VT configuration			■	■		■		■	■			■	■
Open delta VT configuration			■	■		■		■	■			■	■
Sensitive ground	50/51G	Option	Option				Option	Option	Option	Option	Option	Option	Option
Local display/HMI	■	Backlit LCD w/8 pushbuttons	Backlit LCD w/8 pushbuttons	■	■	■	Backlit LCD w/8 pushbuttons	Backlit LCD w/8 pushbuttons	Backlit LCD w/8 pushbuttons	Backlit LCD w/8 pushbuttons	Backlit LCD w/8 pushbuttons	Backlit LCD w/8 pushbuttons	Backlit LCD w/8 pushbuttons
LEDs (local targets)	■	Programmable	Programmable	■	■	■	Programmable	Programmable	Programmable	Programmable	Programmable	Programmable	Programmable

Standards

Description	IEEE Device Number	Feeder Protection			Motor Protection						Transformer Protection		Generator Protection
		DT-3000 V3-T9-123	EDR-3000 V3-T9-133	EDR-5000 V3-T9-142	FP-5000 V3-T9-155	MP-3000 V3-T9-163	MP-4000 V3-T9-173	EMR-3000 V3-T9-179	EMR-4000 V3-T9-191	EMR-5000 V3-T9-204	ETR-4000 V3-T9-123	ETR-5000 V3-T9-123	EGR-5000 V3-T9-241
ANSI		■	■	■	■	■	■	■	■	■	■	■	■
IEC		■	■	■	■	■	■	■	■	■	■	■	■
UL		■	■	■	■	■	■	■	■	■	■	■	■
CE		DT-3030 only	■	■	■			■	■	■	■	■	■
CSA		■	■	■	■	■	■	■	■	■	■	■	■

DT-3000



Contents

<i>Description</i>	<i>Page</i>
Product Selection Guide	V3-T9-117
Digitrip 3000	
EDR-3000 Feeder Protection	V3-T9-133
EDR-5000 Distribution Protection Relay	V3-T9-142
FP-5000 Feeder Protection	V3-T9-155
MP-3000 Motor Protection	V3-T9-163
MP-4000 Motor Protection	V3-T9-173
EMR-3000 Motor Protection Relay	V3-T9-179
EMR-4000 Motor Protection Relay	V3-T9-191
EMR-5000 Motor Protection Relay	V3-T9-204
ETR-4000 Transformer Protection Relay	V3-T9-216
ETR-5000 Transformer Protection Relay	V3-T9-228
EGR-5000 Generation Protection Relay	V3-T9-241
Ground Fault Relay	V3-T9-254
Universal RTD Module	V3-T9-257

Digitrip 3000

Product Description

- Microprocessor-based, three-phase and ground overcurrent relay
- Independent phase and ground measuring circuits and operation
- Inverse time (51), short delay (50, 2) and instantaneous (50) protection
- Eleven time overcurrent characters including ANSI, IEC and thermal protection curves
- Phase and ground ampmeter and peak demand functions
- INCOM communication port
- Fixed mount or optional quick release drawout case design
- Dual-source power supply option for AC control power applications

Application Description

Eaton’s Digitrip 3000 microprocessor-based relay provides reliable three-phase and ground overcurrent protection for all voltage levels. It can be used for

any application where instantaneous and/or time overcurrent protection is required. It is most commonly used as primary feeder circuit protection, see figure below.

Primary Feeder Circuit Protection

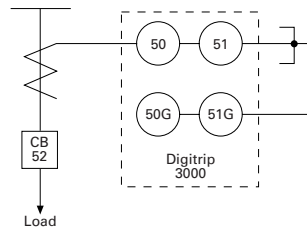

The Digitrip 3000 may be applied as the transformer primary protection or as backup to the differential protection, see figure below.

Transformer Overcurrent Protection

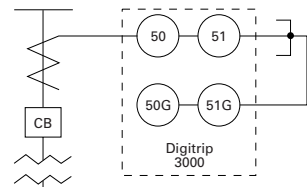

The Digitrip 3000 may be connected to the secondary side of a delta-wye grounded transformer with the ground element connected to a separate CT in the neutral connection of the transformer. With this connection, a lower CT ratio and a pickup setting can be used to provide more sensitive ground fault protection especially for resistance grounded systems, see figure below.

Transformer Secondary Protection with Neutral CT Connection

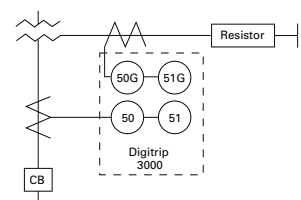

The Digitrip 3000 ground overcurrent element can be connected in the residual circuit of the phase CTs as shown in the top figure or to a separate ground CT as shown in last figure.

Residual Ground Connection

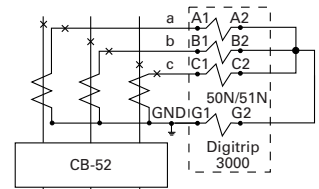

Separate Zero Sequence Ground CT Connection

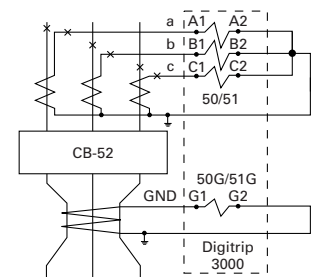

Zone Selective Interlocking (Phase and Ground)

Note: For the phase time overcurrent element, the current sensed by the Digitrip 3000 must exceed 300% ($3 \times I_n$) for the zone selective interlocking to initiate an immediate trip signal.

Zone Selective interlocking is a protection function to minimize equipment damage resulting from a phase or a ground fault in an area where long-time and/or short-time delay is in use.

When the “Ground Zone Interlocking” feature is utilized, an immediate trip is initiated when the fault is in the breaker’s zone of protection, regardless of its preset time delay. When the “Phase Zone Interlocking” feature is utilized, the time overcurrent and short delay phase elements work as follows. The short delay phase element will initiate an immediate trip when the fault is in the breaker’s zone of protection, regardless of its preset time delay. For the time overcurrent phase element, the current sensed by the Digitrip 3000 must exceed 300% ($3 \times I_n$) for the

zone selective interlocking to initiate an immediate trip signal when the fault is in the breaker’s zone of protection.

Upstream Digitrip 3000 protected breakers are restrained from tripping immediately by an interlocking signal from the downstream Digitrip 3000 relay. This interlocking signal requires only a pair of wires from the downstream breaker to the upstream breaker. The Upstream Digitrip 3000 provides time delayed standard coordinated tripping when the fault is located outside the zone of protection.

In the sample zone interlocking system shown below, circuit breakers A, B and C are equipped with Digitrip 3000 overcurrent relays.

Fault Location Zone 3

Note: For the phase time overcurrent element, the current sensed by the Digitrip 3000 must exceed 300% ($3 \times I_n$) for the zone selective interlocking to initiate an immediate trip signal.

If a fault occurs at a point in Zone 3, the Digitrip 3000 of Downstream Breaker C senses the fault and sends a restraining signal to the upstream Digitrip 3000 of Feeder Breaker B.

Having received this signal, the Digitrip 3000 of Feeder Breaker B begins timing for normal final delay tripping. As a result, only Downstream Breaker C is tripped.

Fault Location Zone 2

Note: For the phase time overcurrent element, the current sensed by the Digitrip 3000 must exceed 300% ($3 \times I_n$) for the zone selective interlocking to initiate an immediate trip signal.

If a fault occurs at a point in Zone 2, the Digitrip 3000 of Feeder Breaker B senses the fault and sends a restraining signal to the upstream Digitrip 3000 of Main Breaker A.

The Digitrip 3000 of the Downstream Breaker C does not see this fault since it is situated on the downstream side of the fault.

As a result, the Digitrip 3000 of Downstream Breaker C does not send a restraining signal to the Digitrip 3000 of Feeder Breaker B.

Because there is no restraining signal from the Digitrip 3000 of Downstream Breaker C, the Digitrip 3000 of Feeder Breaker B identifies that the fault is in Zone 2 and immediately trips Feeder Breaker B, regardless of its time setting.

Fault Location Zone 1

Note: For the phase time overcurrent element, the current sensed by the Digitrip 3000 must exceed 300% ($3 \times I_n$) for the zone selective interlocking to initiate an immediate trip signal.

If a fault occurs in Zone 1, no restraining signal is received by the Digitrip of Main Breaker A. As a result, Main Breaker A is immediately tripped by its Digitrip overcurrent relay, regardless of its time setting.

Sample Zone Selective Interlocking System

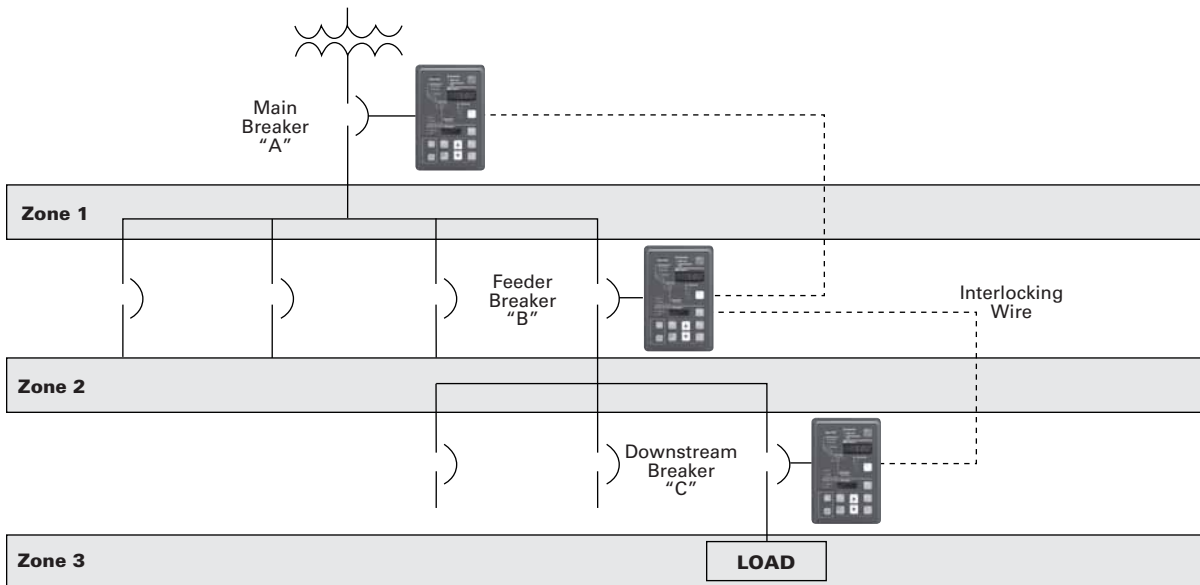

Features, Benefits and Functions

- Complete current protection and metering in a single compact case reduces panel space, wiring and cost
- Selectable trip characteristics simplify ordering and reduces inventory
- Optional drawout case provides easy and quick removal and replacement of the relay
- Optional dual-source power supply provides reliable protection when applied with ac control power, eliminating the need for batteries or UPS
- Integral ampmeter and display replaces separate meter and switch, saving panel space, wiring and money
- Zone selective interlocking improves coordination and tripping times and can save money by using in place of traditional bus differential
- Integral test function and microprocessor design can reduce maintenance time and expense

Standards and Certifications

- UL recognized
- UL 1053 recognized
- ANSI C37.90
- ANSI C37.90.1 (1989)
- ANSI C37.90.2 (1995)

Note: Fixed case versions meet 35 V/m. Drawout case versions meet 28 V/m.

- IEC 255
- CE (DT3030/3031 version only)



Product Selection

DT-3000

DT-3000



Description

Description	Catalog Number
DT-3000 protective relay	DT3000
DT-3000 protective relay Chicago version	DT3100
DT-3030 protective relay (24–48 Vdc CE Mark version)	DT3030
DT-3000 drawout case protective relay	DT3001
DT-3000 Chicago version drawout case protective relay	DT3101
DT-3030 drawout case protective relay (24–48 Vdc CE Mark version)	DT3031
DT-3000 protective relay with 120 Vac dual-source power supply	DT3010
DT-3000 protective relay with 240 Vac dual-source power supply	DT3020

9

Options and Accessories

Additional Products by Eaton's Cutler-Hammer Series

Dual-Source Power Supply Option

The Digitrip 3000 with Dual-Source Power Supply (DSPS) is available in two versions, DT-3010 and DT-3020. They include an integral power supply module that:

- Powers the relay from nominal 120 Vac, 50/60 Hz (DT-3010 model) or 240 Vac, 50/60 Hz (DT-3020 model) auxiliary power, which is normally connected and available.
- Operates solely from the main current transformers (CTs) during a fault if the normally connected auxiliary ac voltage is not available, like an electromechanical relay or an electronic "self-powered" relay

Functional Description

The integral Dual-Source Power Supply (DSPS) contains one AC voltage transformer and three AC current transformers. The AC voltage transformer is used to supply nominal ac control power to the unit. The current transformers are used to power the unit from the line current. Normally, the unit will operate from the AC auxiliary voltage.

Because this voltage is usually obtained from the system containing the circuit that the relay is protecting, a fault on the protected line could cause the AC voltage to drop below an acceptable operating level. Below approximately 70 volts for DT-3010 or 140 volts for DT-3020, the DSPS switches over to current powering.

All three current transformer secondaries are connected in series to supply this power. The DSPS will supply enough power to operate the Digitrip 3000 overcurrent relay in the tripped state with currents greater than 1.8 per unit rated secondary current, or 9 A, in a single-phase. The DSPS will operate with three-phase currents in a tripped state with currents greater than 1.2 per unit or 6 A rated secondary current.

Note: There will be no effect to the DT-3000 relay trip time accuracy when the Dual-Source Power Supply switches from normal ac voltage to fault-current power.

Burden Data

In normal operating conditions, the burden is <0.08 ohms with three-phase 1 A CT current, or 0.2 per unit, and drops to less than 0.04 ohms at high current levels. Present CT burden data in ohms and volt-amperes, see **Page V3-T9-128**. In these cases, the burden shown is the total CT terminal value, which is the DSPS plus the relay measuring circuits, for the indicated operating condition.

The trip curve on **Page V3-T9-128**, right, shows burden impedance magnitude in ohms. The two lower curves are the values with AC power applied; the upper two are with CT powering only. For each of these pairs, one curve shows the burden for a single-phase current (representing a single-phase-to-ground fault) and the other for three balanced phases with normally arrayed 120-degree phase angle increments. There is no phase sequence sensitivity.

Page V3-T9-128, trip curve, upper left, shows the burden in volt-amperes for the same four cases.

Digitrip 3000 Optional Drawout Case

The Digitrip 3000 overcurrent protective relay is available in a new drawout case for quick release, removal and replacement of the unit without disruption of the wiring. The CT circuits are self-shortening to prevent damaging voltages from existing across-the-current transformer windings. All voltage inputs, discrete inputs and contact inputs are disconnected while maintaining security against false tripping.

The terminal blocks feature a two-stage disconnect operation. Removal of the DT-3000 Inner Chassis will disconnect the trip circuits and short the CT secondaries before the unit control power is disconnected. Upon insertion of the Inner Chassis, the control power connections are made before the trip circuits are activated. **This feature provides added security against false tripping.**

Technical Data and Specifications

Current Inputs

- CTs: 5 A secondary
- CT Burden:
 - <0.004 ohm at rated current (5 A)
 - <0.1 VA at rated current (5 A)
- I_n : 5 A (Secondary) or CT (Primary)
- Saturation: 30 x I_n
- CT thermal ratings:
 - 10 A continuous
 - 500 A for 1 second

CT (Primary) Settings Available

- Phase and ground: 5/10/25/50/75/100/150/200/250/300/400/500/600/630/800/1000/1200/1250/1500/1600/2000/2400 2500/3000/3200/4000/5000

Input Voltage DT-3000

- Nominal:
 - 48–250 Vdc
 - 120–240 Vac 50/60 Hz
- Operating range:
 - 28–280 Vdc
 - 90–254 Vac 50/60 Hz

Power Consumption

	24	48	125	250	120	240
Vdc	10 W	10 W	10 W	10 W	10 VA	18 VA

Input Voltage Digitrip 3030/3031

Description	DT-3010	DT-3020
Nominal	120 Vac	240 Vac
Operating Range	70–132 Vac	140–264 Vac
Power Consumption	15 VA	15 VA

Output Trip Contacts (Trip OC/Comm., Trip Inst. and Comm. Close)

- Momentary:
 - Make 30 A AC/DC for 0.25 seconds
 - Break 0.25 A at 250 Vdc
 - Break 5 A at 120/240 Vac
- Continuous:
 - 5 A at 120/240 Vac
 - 5 A at 30 Vdc
 - Meets ANSI C37.90, Paragraph 6.7

Environmental Conditions

- Operating temperature: –22 °F to +131 °F (–30 °C to +55 °C)
- Operating humidity: 0–95% relative humidity (noncondensing)
- Storage temperature: –40 °F to +185 °F (–40 °C to +70 °C)

Auxiliary Alarm Contacts

- 5 A continuous at 120/240 Vac, 30 Vdc
- 5 A break at 120/240 Vac, 30 Vdc

Tests

- Dielectric strength, current inputs:
 - 3000 Vac for 1 minute
 - Phase-to-phase
- Seismic test: Meets requirements for UBC® and California Building Code Zone 4. ZPA = 3.5

Phase and Ground Time-Current Curves

- Thermal:
 - I_t (Moderately Inverse)
 - I^2t (Very Inverse)
 - I^4t (Extremely Inverse)
 - FLAT (Definite Time)
- ANSI (Per ANSI C37.112, 1996):
 - Moderately Inverse
 - Very Inverse
 - Extremely Inverse

- IEC (Per IEC 255-3, 1989):
 - IEC-A (Moderately Inverse)
 - IEC-B (Very Inverse)
 - IEC-C (Extremely Inverse)
 - IEC-D (Definite Time)

Overcurrent Functions and Pickup Ranges

Note: Consult factory for sensitive ground fault.

- Long Delay or Inverse Time Overcurrent:
 - Phase: (0.2–2.2) x I_n (29 settings)
 - Ground: (0.1–2.0) x I_n , None (26 settings)
- Short Delay:
 - Phase: (1–11) x I_n , None (25 settings)
 - Ground: (0.1–11) x I_n , None (45 settings)
- Instantaneous:
 - Phase: (1–25) x I_n , None (30 settings)
 - Ground: (0.5–11) x I_n , None (33 settings)

Time Delay Settings

- Inverse Time Overcurrent Time Multiplier:
 - Thermal: 0.2–40 (47 settings)
 - FLAT: 0.2–2 (21 settings)
 - ANSI (all): 0.1–5.0 (50 settings)
 - IEC (all): 0.05–1.00 (20 settings)
- Short Delay Time: 0.05–1.5 seconds (22 settings)

Current Monitoring

Note: Consult factory for sensitive ground fault.

- True rms sensing: three-phase and ground
- Display accuracy:
 - ±1% of Full Scale [I_n] from 0.04 x I_n to 1 x I_n
 - ±2% of Full Scale [I_n] from 1 x I_n to 2 x I_n
- Ampere demand: Average demand over 5 minute sampling window
- High load (with selectable output): 85% of Inverse Time Overcurrent setting

Timing Accuracy

- Inverse Time Overcurrent: ±10% at >1.5 x Pickup
- Short Delay Time: ±50 ms

Communications

- Eaton's PowerNet Compatible
- Built-in INCOM
- Data rate is 1200 or 9600 baud

Drawout Case

- Refer to **Page V3-T9-131** for Drawout Case Dimensions

Terminal Block

- Make/Break rating:
 - 10 A at 240 Vac nominal
 - 0.25 A at 280 Vdc maximum
- Terminal wire gauge: No. 14 to No. 10 AWG
- Screw torque requirements: 18-inch-pounds

Reference Information

Cross-Reference

There are several products that are equivalent to the Digitrip 3000. The following lists the competitor's name and equivalent product to the Digitrip 3000. In general, the Digitrip 3000 can be used in place of the competitive product.

- ABB® MMCO, 51
- Basler Electric® BEI-51
- GE Multilin MDP, 735, 737
- Siemens® 7SJ 511, 7SJ 60

Trip Curve Charts

Digitrip 3000 With Dual-Source Power Supply Burden Curves

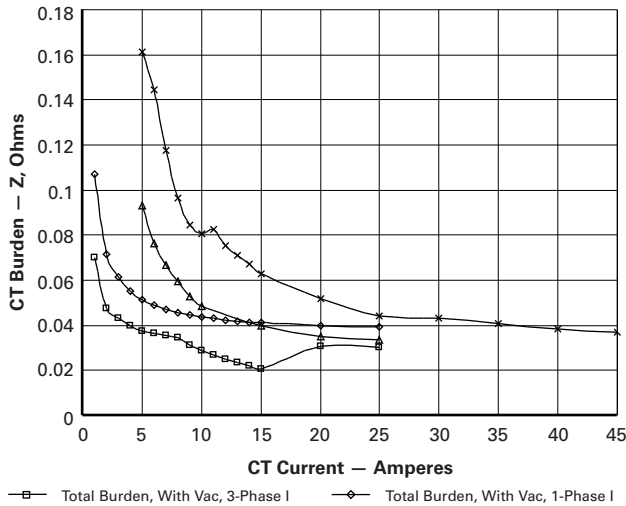

Digitrip 3000 With Dual-Source Power Supply CT Power Volt-Ampere Curves

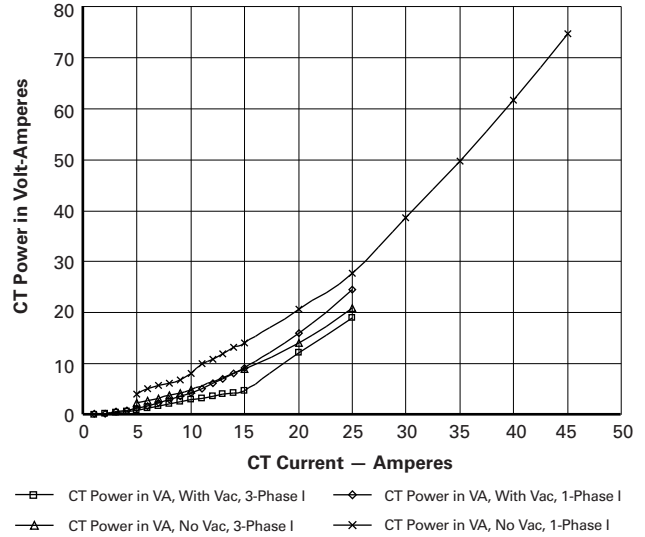

Wiring Diagrams

Digitrip 3001

Typical wiring diagram for the fixed mount version.

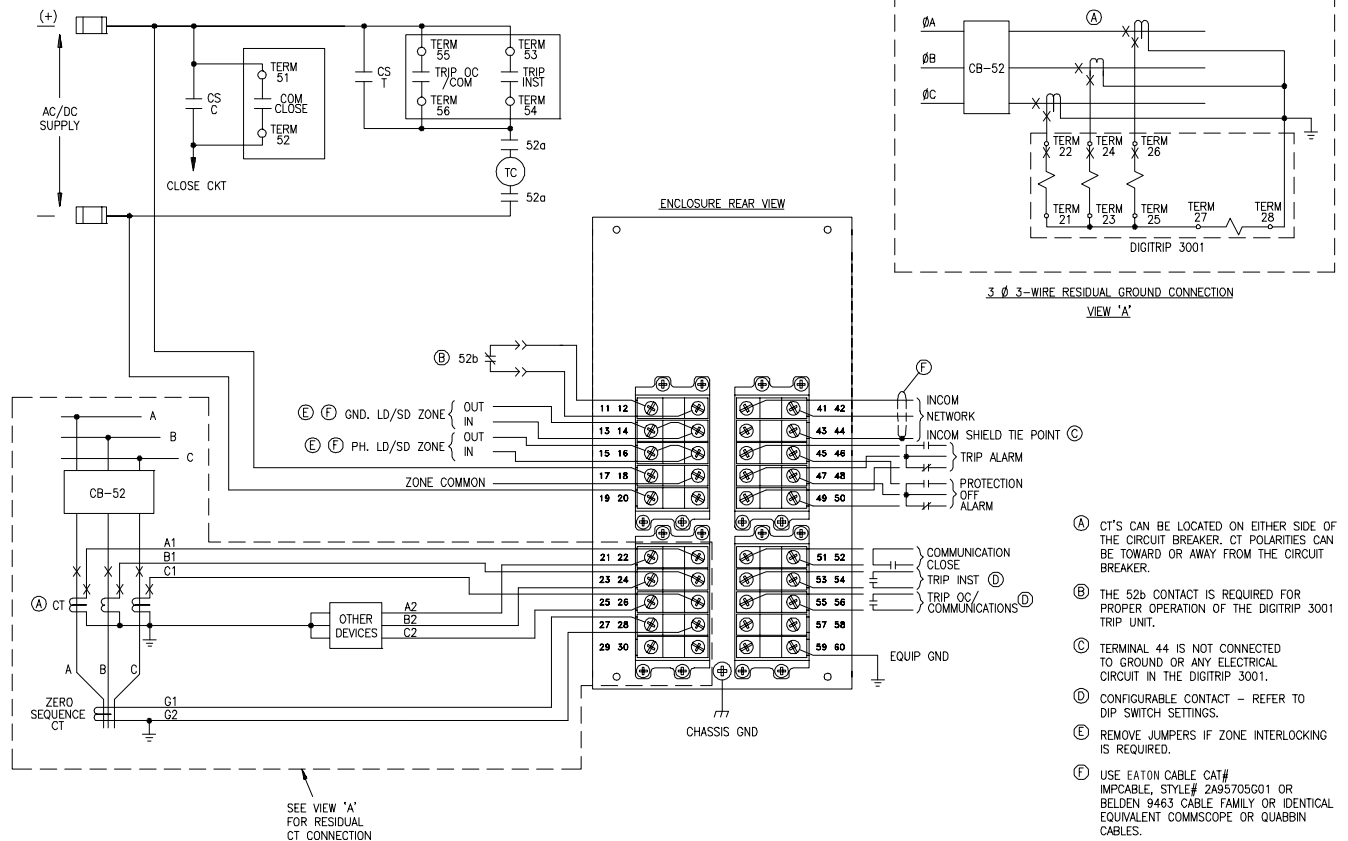

Approximate Dimensions in Inches (mm)

Digitrip 3010/3020

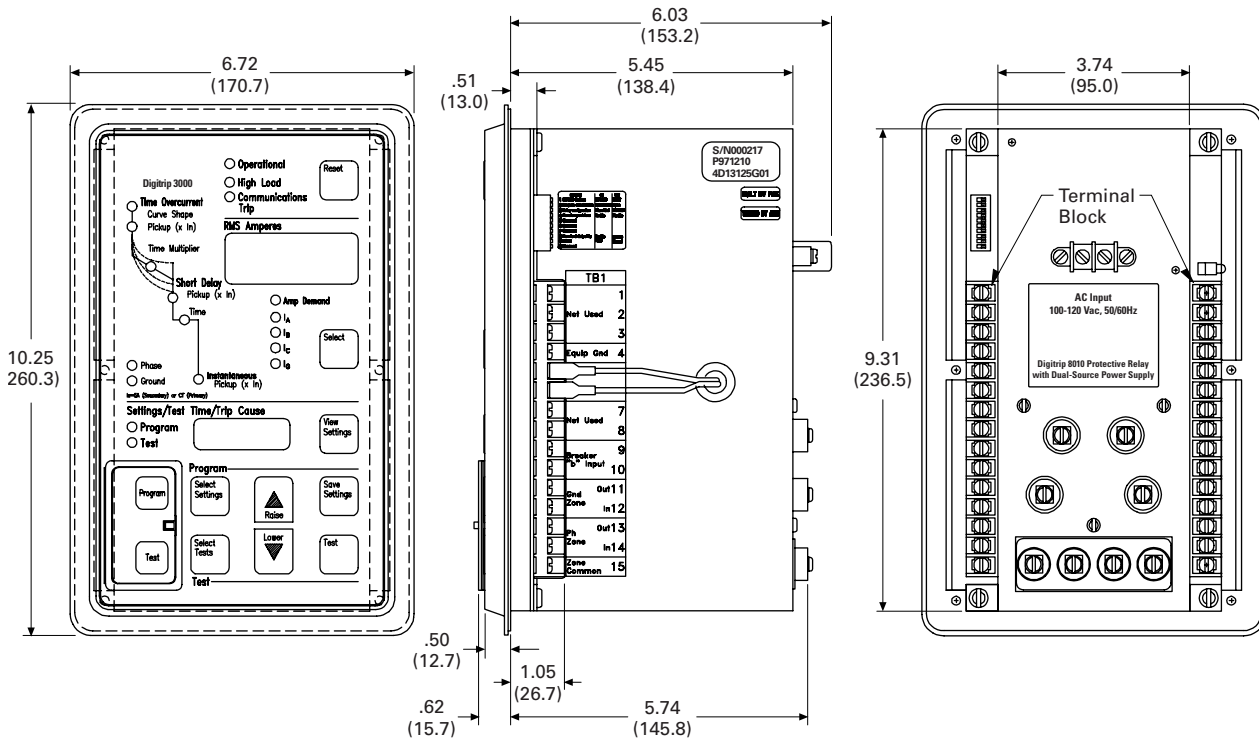

Digitrip 3000

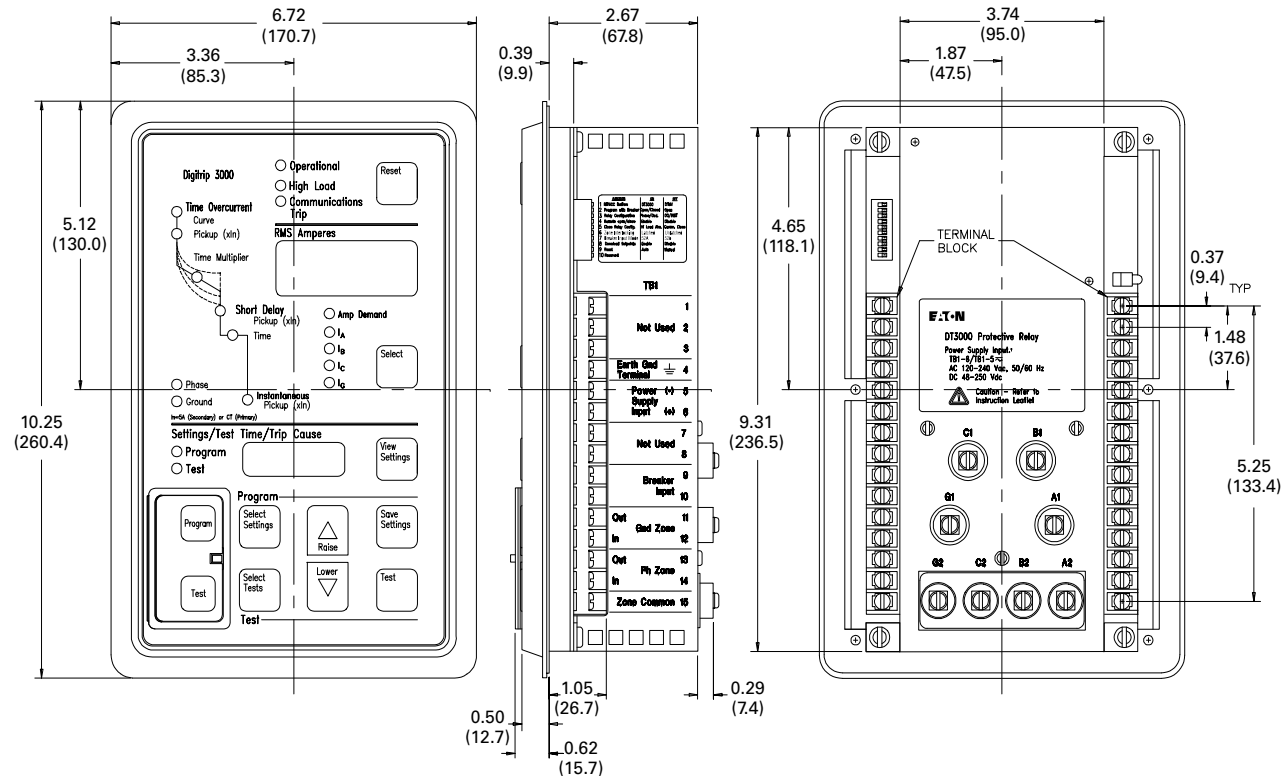

9.3

Metering Devices, Protective Relays, Software and Connectivity

Protective Relays

Approximate Dimensions in Inches (mm)

Rear View of Digitrip 3001 Drawout Outer Case Terminal Layout

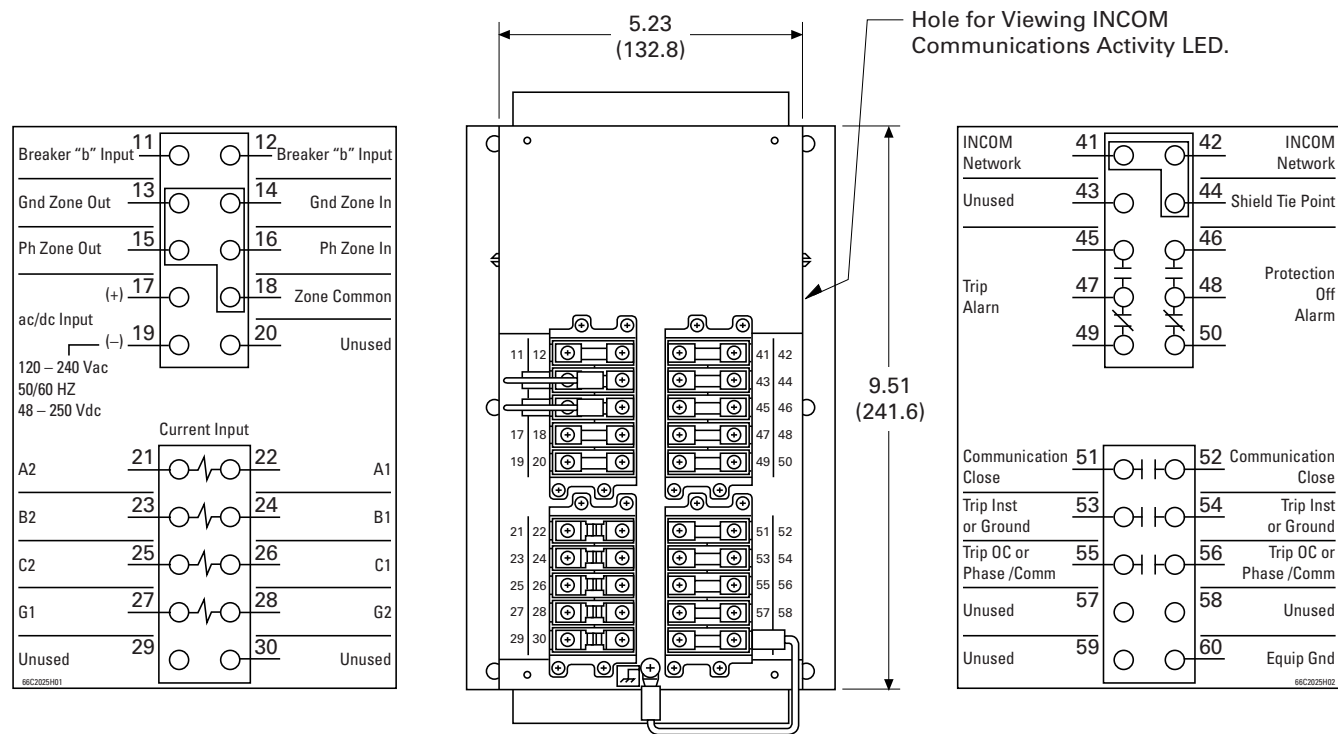

Digitrip 3000 Feeder Protection Relay (Fixed Case)

Height	Width	Depth	Shipping Weight Lbs (kg)
10.25 (260.4)	6.72 (170.7)	2.96 (75.2)	0.0 (0.0)

EDR-3000



Contents

<i>Description</i>	<i>Page</i>
Product Selection Guide	V3-T9-117
Digitrip 3000	V3-T9-123
EDR-3000 Feeder Protection	
EDR-5000 Distribution Protection Relay	V3-T9-142
FP-5000 Feeder Protection	V3-T9-155
MP-3000 Motor Protection	V3-T9-163
MP-4000 Motor Protection	V3-T9-173
EMR-3000 Motor Protection Relay	V3-T9-179
EMR-4000 Motor Protection Relay	V3-T9-191
EMR-5000 Motor Protection Relay	V3-T9-204
ETR-4000 Transformer Protection Relay	V3-T9-216
ETR-5000 Transformer Protection Relay	V3-T9-228
EGR-5000 Generation Protection Relay	V3-T9-241
Ground Fault Relay	V3-T9-254
Universal RTD Module	V3-T9-257

EDR-3000 Feeder Protection

Product Description

The EDR-3000 Protective Relay is a multifunction, microprocessor-based overcurrent relay designed for both ANSI and IEC applications. It is a panel-mounted, self-contained unit that operates from either AC or DC control power. The EDR-3000 design provides true rms and fundamental sensing of each phase and ground current. Only one unit is required for each three-phase circuit.

Current monitoring and operator selectable protective functions are integral to each relay. The EDR-3000 relay operates from the 5 A or 1 A secondary output of standard current transformers. Current transformer ratio information is quickly programmed into the unit via settings. This enables the relay to display metered current in primary amperes, secondary amperes or per unit values. The EDR-3000 features a user-friendly operations panel to monitor and program the relay. Operating parameters and troubleshooting information are displayed in the 128 x 64 LCD. In addition, all data and information can be

communicated to a host computer equipped with PowerPort-E™. A "Communication Trip" and "Communication Close" control command can also be initiated by a host computer with an authorized access code for remote breaker operation.

Application Description

The EDR-3000 microprocessor-based relay provides reliable three-phase and ground overcurrent protection for all voltage levels. It can be used for any application where instantaneous and/or time overcurrent protection is required. It is most commonly used as primary feeder circuit protection, shown below.

Primary Feeder Circuit Protection

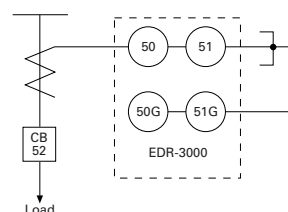

The EDR-3000 may be applied as the transformer primary protection or as backup to the differential protection, see below.

Transformer Overcurrent Protection

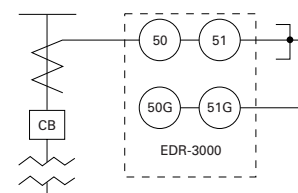

The EDR-3000 may be connected to the secondary side of a delta-wye grounded transformer with the ground element connected to a separate CT in the neutral connection of the transformer. With this connection, a lower CT ratio and a pickup setting can be used to provide more sensitive ground fault protection especially for resistance grounded systems, shown below.

Transformer Secondary Protection with Neutral CT Connection

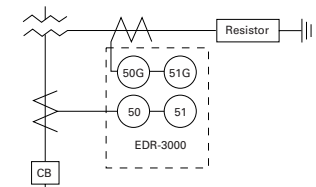

The EDR-3000 relay has special provisions for connection in a Zone Interlocking scheme that can be used for bus protection or to improve protection coordination in a tight or close system. Zone Interlocking is described in following sections. In addition the EDR-3000 has multiple setting groups that can be used to reduce arc flash hazard with instantaneous elements.

Residual Ground Connection

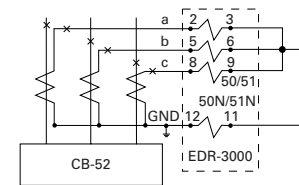

Overcurrent Protection

The EDR-3000 provides complete three-phase and ground protection with separate elements and settings. The relay can be used with CTs from 1 to 50,000 A of primary current and 1 or 5 A of secondary current. The CT ratio can be set independently for phase and ground, allowing the ground element to be connected in either the residual or the separate ground CT configuration, shown on below.

Separate Zero Sequence Ground CT Connection

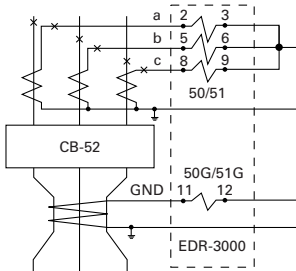

Zone Selective Interlocking (Phase and Ground)

Note: Refer to the Ordering Information and (Catalog Ordering Information) for optional features, see **Page V3-T9-136**.

Zone Selective interlocking is a protection function to minimize equipment damage resulting from a phase or a ground fault in an area where long time and/or short time delay is in use.

When the "Ground Zone Interlocking" feature is utilized, an immediate trip is initiated when the fault is in the breaker's zone of protection, regardless of its preset time delay. When the "Phase Zone Interlocking" feature is utilized, the time overcurrent elements work as follows. The instantaneous phase element will initiate an immediate trip when the fault is in the breaker's zone of protection, regardless of its preset time delay. For the time overcurrent phase element, the current sensed by the EDR-3000 must exceed 1.5 times the pickup setting for the zone selective interlocking to initiate an immediate trip signal when the fault is in the breaker's zone of protection.

Upstream EDR-3000 protected breakers are restrained from tripping immediately by an interlocking signal from the downstream EDR-3000 relay. This interlocking signal requires only a pair of wires from the downstream breaker to the upstream breaker. It provides standard

coordinated tripping when the fault is located outside the zone of protection.

In the sample zone interlocking system shown below, circuit breakers A, B and C are equipped with EDR-3000 overcurrent relays.

Fault Location Zone 3

Note: For the time overcurrent phase element, the current sensed by the EDR-3000 must exceed 1.5 times the pickup setting for the zone selective interlocking to initiate an immediate trip signal when the fault is in the breaker's zone of protection.

If a fault occurs at a point in Zone 3, the EDR-3000 of downstream breaker C senses the fault and sends a restraining signal to the upstream EDR-3000 of feeder breaker B. As a result, only downstream breaker C is tripped.

Fault Location Zone 2

Note: For the time overcurrent phase element, the current sensed by the EDR-3000 must exceed 1.5 times the pickup setting for the zone selective interlocking to initiate an immediate trip signal when the fault is in the breaker's zone of protection.

If a fault occurs at a point in Zone 2, the EDR-3000 of feeder breaker B senses the fault and sends a restraining signal to the upstream EDR-3000 of main breaker A. The EDR-3000 of the downstream breaker C does not see this fault since it is situated on the downstream side of the fault. As a result, the EDR-3000 of downstream breaker C does not send a restraining signal to the EDR-3000 of feeder breaker B. Since it did not receive a restraining signal from the EDR-3000 of downstream breaker C, the EDR-3000 of feeder breaker B identifies that the fault is in Zone 2 and immediately trips feeder breaker B, regardless of its time setting.

Fault Location Zone 1

Note: For the time overcurrent phase element, the current sensed by the EDR-3000 must exceed 1.5 times the pickup setting for the zone selective interlocking to initiate an immediate trip signal when the fault is in the breaker's zone of protection.

If a fault occurs in Zone 1, no restraining signal is received by the Digitrip of main breaker A. As a result, main breaker A is immediately tripped by its EDR-3000 overcurrent relay, regardless of its time setting.

Sample Zone Selective Interlocking System

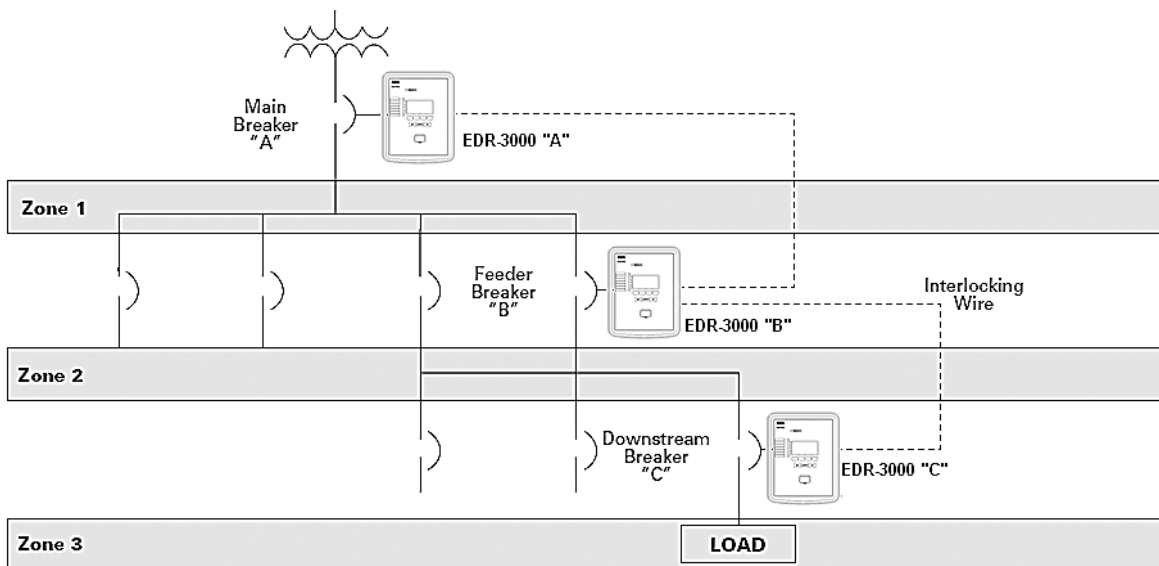

Features, Benefits and Functions

Applications

- Provides reliable three-phase and ground overcurrent protection for all voltage levels
- Primary feeder circuit protection
- Primary transformer protection
- Backup to differential protection
- May be used where instantaneous and/or time overcurrent protection is required
- Ground element capable of residual, zero sequence or external source connections

Protection Functions

- Breaker failure (50BF)
- Phase overcurrent protection per time-current curve (51-1, 51-2, 51-3)
- Calculated ground fault protection per time-current curve (51R-1, 51R-2)
- Independent measured ground or neutral fault protection per time-current curve (51X-1, 51X-2)
- Phase instantaneous overcurrent (50-1, 50-2, 50-3)
- Calculated ground or neutral instantaneous overcurrent (50R-1, 50R-2)
- Independent measured ground or neutral instantaneous overcurrent (50X-1, 50X-2)
- Curve shapes: ANSI, IEC, or thermal curves (11 thermal curves)
- Instantaneous or time delay reset
- True rms or fundamental sensing of each phase and ground current
- Zone selective interlocking (phase and ground) or reverse blocking for bus protection

Note: Refer to the Ordering Information and **Page V3-T9-136** (Catalog Ordering Information) for optional features.

Metered Values

- rms and fundamental phase currents
- rms and fundamental ground currents
- Maximum, minimum and average rms and fundamental phase currents
- Maximum, minimum and average rms and fundamental ground currents

Monitored and Data Recording Values

- Trip circuit monitoring

Note: Refer to the Ordering Information and **Page V3-T9-136** (Catalog Ordering Information) for optional features.

- Breaker wear (accumulated interrupted current)
- Fault data logs (up to 20 events)
- Sequence of event recorder (1 ms time stamp, last 300 events)
- Waveform capture (7200 cycles total)
- Trip Cause displays fault recorder data on HMI after fault event
- CT supervision

Control Functions

- Remote open/close
- Programmable I/O
- Programmable LEDs
- Multiple setting groups (up to four)

Communication Software

- Local HMI
- Front RS-232 port
- Rear RS-485 port
- Protocols
 - Modbus RTU
 - Modbus TCP (option)
 - IEC 61850 (option)
 - IRIG-B (option)
 - SNTP (option)

PowerPort-E

PowerPort-E is the software program used to configure off-line protection setting files for all E-Series relay models. PowerPort-E is also used for viewing measured values of the relays in real-time, uploading/downloading setting files, and retrieving event log and waveform records.

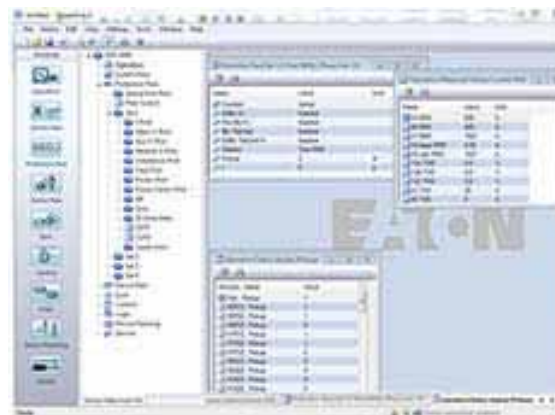

Waveform Capture (Quality Manager)

The EDR-3000 relay provides oscillographic recording capabilities. The relay will record all measured signals along with the binary signals of pickup, trip, internal logic, and contact inputs. The EDR-3000 can record up to 7200 cycles of data. The number of records is proportional to the programmed size of each record; the maximum size per

record is 600 cycles. The waveform capture is initiated by up to 8 different triggers (i.e., trip/alarm events) or manually via communications or the HMI. PowerPort-E setting software is used to retrieve the records. Quality Manager is a separate software program downloaded with PowerPort-E used for analyzing the waveform and trending files retrieved from the relay.

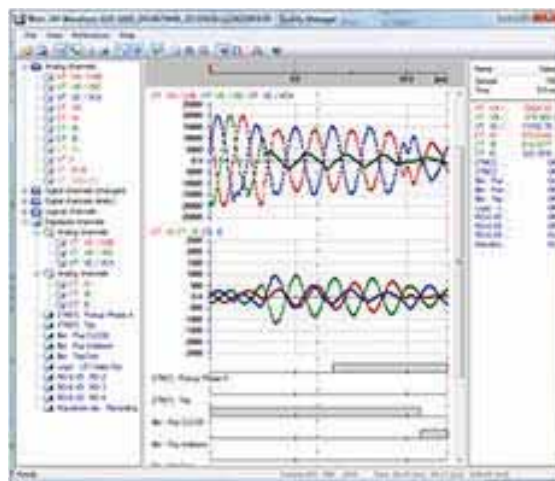

Standards and Certifications

- Generic standard:
 - EN 61000-6-2
 - EN 61000-6-3
- Product standard:
 - EC 60255-6
 - EN 50178
- UL 508 (Industrial Control Equipment)
- CSA C22.2 No. 14-95 (Industrial Control Equipment)
- ANSI C37.90
- UL, CSA, CE



Catalog Number Selection

The catalog number identification chart defines the electrical characteristics and operation features included in the EDR-3000. For example, if the catalog number is EDR-3000-2A0BA1, the device would have the following:

EDR-3000

(A)—Four digital inputs, four output relays

(0)—Phase current 5 A / 1 A, Ground Current 5 A / 1 A, Power supply: 19–300 Vdc, 40–250 Vac

(B)—Modbus-RTU (RS-485)

(A)—Without conformal coating

(1)—Projection panel mount

Relay Removable Terminals

EDR-3000-2A 0 B A 1

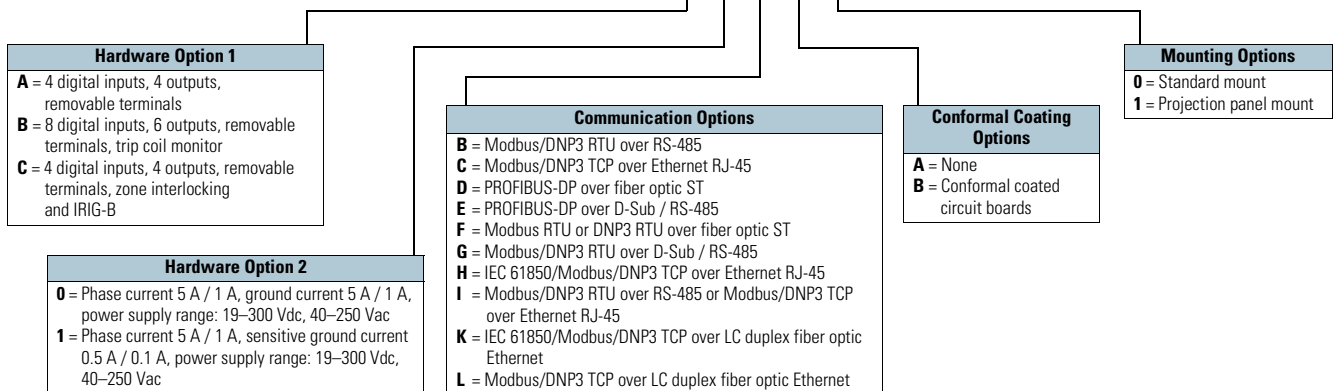

Technical Data and Specifications

Climatic Environmental Conditions

- Storage temperature: -13 °F to 158 °F (-25 °C up to +70 °C)
- Operating temperature: -4 °F to 140 °F (-20 °C up to +60 °C)
- Permissible humidity at ann. average: <75% rel. (on 56d up to 95% rel.)
- Permissible Installation altitude:
 - <2000 m (6561.67 ft) above sea level
 - If 4000 m (13,123.35 ft) altitude apply, a changed classification of the operating and test voltages may be necessary

Degree of Protection EN 60529

- HMI front panel with seal: IP54
- Rear side terminals: IP30

Routine Test

- Insulation test according to IEC 60255-5: All tests to be carried out against ground and other input and output circuits
- Aux. voltage supply, digital inputs, current measuring inputs, signal relay outputs: 2.5 kV (eff)/50 Hz
- Voltage measuring inputs: 3.0 kV (eff)/50 Hz
- All wire-bound communication interfaces: 1.5 kV DC

Housing

- Material, housing: aluminum extruded section
- Material, front panel: aluminum/foil front
- Mounting position: horizontal ($\pm 45^\circ$ around the X-axis must be permitted)

Plug-in Connector with Integrated Short-Circuiter (Conventional Current Inputs)

- Nominal current: 1 A and 5 A
- Continuous loading capacity: $4 \times I_n$ /continuously
- Overcurrent withstand: $30 \times I_n/10$ s
- $100 \times I_n/1$ s
- $250 \times I_n/10$ ms (1 half-wave)
- Screws: M4, captive type according to VDEW
- Connection cross-sections:
 - $2 \times 2.5 \text{ mm}^2$ (2 x AWG 14) with wire end ferrule
 - $1 \times$ or $2 \times 4.0 \text{ mm}^2$ (2 x AWG 12) with ring cable sleeve or cable sleeve
 - $1 \times$ or $2 \times 6 \text{ mm}^2$ (2 x AWG 10) with ring cable sleeve or cable sleeve

Voltage Supply

- Aux. voltage: 19–300 Vdc/40–250 Vac
- Buffer time in case of supply failure: ≥ 50 ms at minimal aux. voltage communication is permitted to be interrupted
- Max. permissible making current:
 - 18 A peak value for <0.25 ms
 - 12 A peak value for <1 ms
- The voltage supply must be protected by a fuse of:
 - 2.5 A time-lag miniature fuse 5×20 mm (approx. $1/5$ in x 0.8 in) according to IEC 60127
 - 3.5 A time-lag miniature fuse 6.3×32 mm (approx. $1/4$ in x $1 1/4$ in) according to UL 248-14

Power Consumption

- Power supply range: Power consumption in idle mode
- Max. power consumption
- 19–300 Vdc: 6 W 8.5 W
- 40–250 Vac
- For frequencies of 40–70 Hz: 6 W 8.5 W

Real-Time Clock

- Running reserve of the real-time clock: 1 year min.

Display

- Display type: LCD with LED background illumination
- Resolution graphics display: 128 x 64 pixel
- LED-type: two colored, red/green
- Number of LEDs, housing B1: 8

Digital Inputs

- Max. input voltage: 300 Vdc/270 Vac
- Input current: <4 mA
- Reaction time: <20 ms
- Fallback time: <30 ms (safe state of the digital inputs)
- Four switching thresholds: $U_n = 24 \text{ Vdc}, 48 \text{ Vdc}, 60 \text{ Vdc}, 110 \text{ Vac/Vdc}, 230 \text{ Vac/Vdc}$ $U_n = 24 \text{ Vdc}$
 - Switching threshold 1 ON
 - Switching threshold 1 OFF
 - Min. 19.2 Vdc
 - Max. 9.6 Vdc
 - $U_n = 48 \text{ V}/60 \text{ Vdc}$
 - Switching threshold 2 ON
 - Switching threshold 2 OFF
 - Min. 42.6 Vdc
 - Max. 21.3 Vdc
 - $U_n = 110/120 \text{ Vac/Vdc}$
 - Switching threshold 3 ON
 - Switching threshold 3 OFF
 - Min. 88.0 Vdc/88.0 Vac
 - Max. 44.0 Vdc/44.0 Vac
 - $U_n = 230/240 \text{ Vac/Vdc}$
 - Switching threshold 4 ON
 - Switching threshold 4 OFF
 - Min. 184 Vdc/184 Vac
 - Max. 92 Vdc/92 Vac
- Terminals: screw-type terminal

Current and Ground Current Measurement

- Nominal currents: 1 A / 5 A
- Max. measuring range:
 - up to $40 \times I_n$ (phase currents)
 - up to $25 \times I_n$ (ground current standard)
 - up to $2.5 \times I_n$ (ground current sensitive)
- Continuous loading capacity: $4 \times I_n$ /continuously
- Overcurrent proof:
 - $30 \times I_n/10$ s
 - $100 \times I_n/1$ s
 - $250 \times I_n/10$ ms (1 half-wave)
- Power consumption: Phase current inputs
 - at $I_n = 1$ A S = 0.15 MVA
 - at $I_n = 5$ A S = 0.15 MVA
- Ground current input
 - at $I_n = 1$ A S = 0.35 MVA
 - at $I_n = 5$ A S = 0.35 MVA
- Frequency range: 50 Hz/60 Hz $\pm 10\%$
- Terminals: Screw-type terminals with integrated short-circuiters (contacts)

Binary Output Relays

- Continuous current: 5 A AC/DC
- Switch-on current: 25 A AC/DC for 4 s
- Max. breaking current: 5 A AC up to 125 Vac
- 5 A DC up to 50 V (resistive)
- 0.2A DC at 300 V
- Max. switching voltage: 250 Vac/300 Vdc
- Switching capacity: 2000 VA
- Contact type: 1 changeover contact
- Terminals: Screw-type terminals

Front Interface RS-232

- Baud rates: 115,200 baud
- Handshake: RTS and CT
- Connection: 9-pole D-Sub plug

RS-485

- Master/slave: slave
- Connection: 6 screw-clamping terminals RM 3.5 mm (138 MIL) (terminating resistors internal)

Tolerances of the Real-Time Clock

- Resolution: 1 ms
- Tolerance: <1 minute/month (+20 °C)

Measuring Accuracy

- Max. measuring range: up to $40 \times I_n$ (phase currents) up to $25 \times I_n$ (ground current standard)
- Frequency range: 50 Hz/60 Hz $\pm 10\%$
- Accuracy: Class 0.5
- Amplitude error if $I < I_n$: $\pm 0.5\%$ of the rated value
- Amplitude error if $I > I_n$: $\pm 0.5\%$ of the measured value
- Amplitude error if $I > 2 I_n$: $\pm 1.0\%$ of the measured value
- Resolution: 0.01 A
- Harmonics up to 20% 3rd harmonic $\pm 2\%$ up to 20% 5th harmonic $\pm 2\%$
- Frequency influence < $\pm 2\%/Hz$ in the range of ± 5 Hz of the parameterized nominal frequency
- Temperature influence < $\pm 1\%$ within the range of 0 °C up to +60 °C

Wiring Diagrams

EDR-3000

Connection Example Clockwise Rotating Field
EDR3000 => Terminal Markings X3.

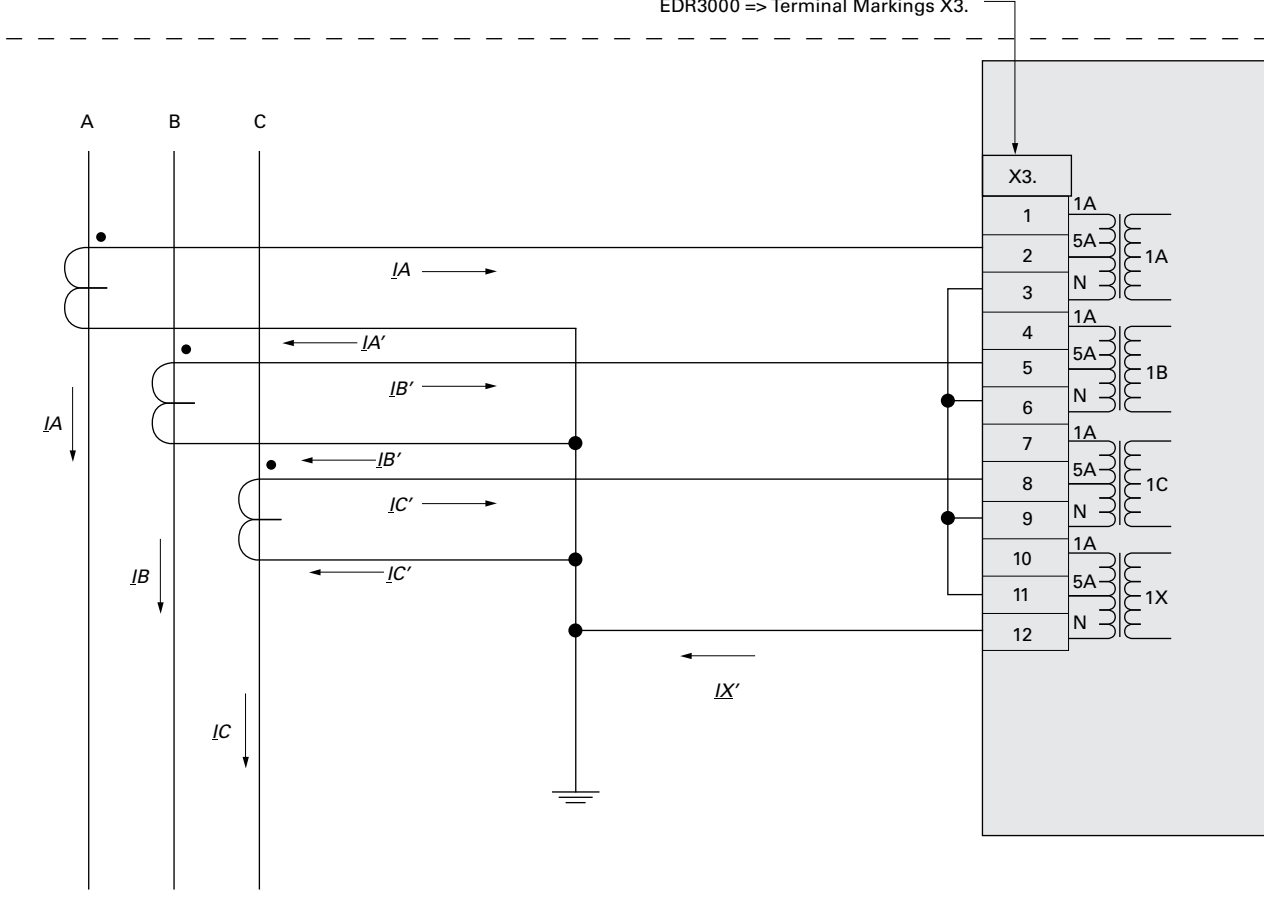

Three-Phase Current Measurement; I_{nom} Secondary = 5 A
Ground Current Measuring via Residual Connection; I_{Gnom} Secondary = 5 A

Dimensions

Approximate Dimensions in Inches (mm)

Drilling Pattern

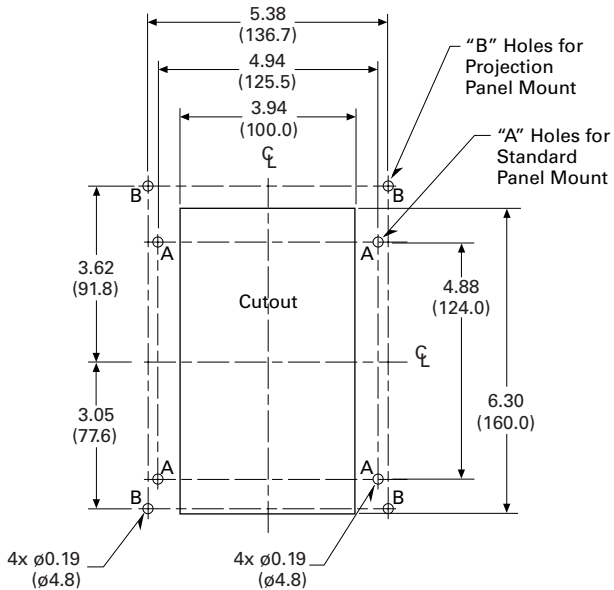

Projection Mounting

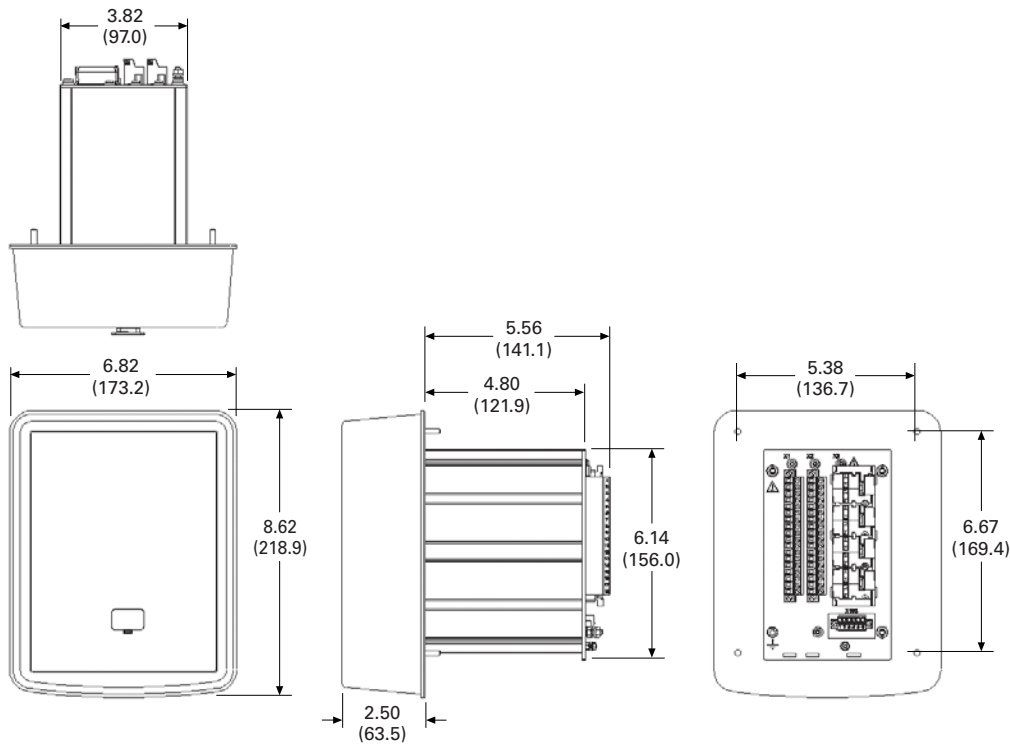

Approximate Dimensions in Inches (mm)

Standard Mounting

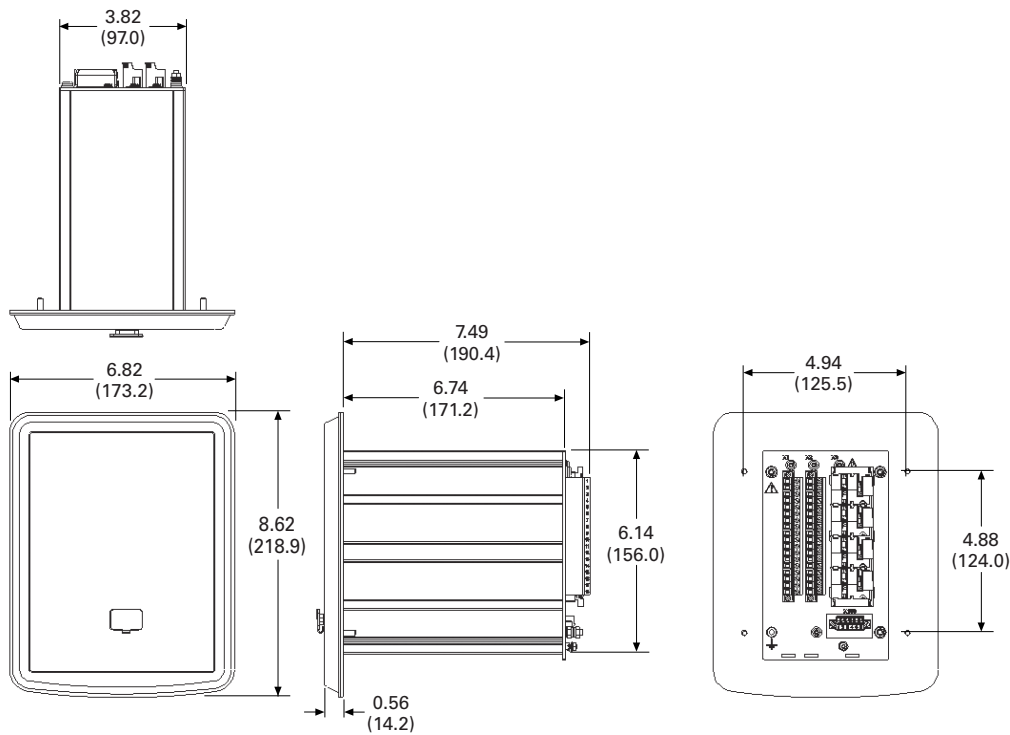

EDR-3000

Width	Height	Depth
6.82 (173.2)	8.62 (218.9)	7.49 (190.2) ①

EDR-3000 Housing B1

Width	Height	Depth	Shipping Weight Lbs (kg)
5.57 (141.5)	7.21 (183.0)	8.19 (208.0) ②	5.3 (2.4)

Notes

- ① Depth behind panel with projection mounted enclosure.
- ② Includes terminals.

EDR-5000 Distribution Protection Relay



Contents

<i>Description</i>	<i>Page</i>
Product Selection Guide	V3-T9-117
Digitrip 3000	V3-T9-123
EDR-3000 Feeder Protection	V3-T9-133
EDR-5000 Distribution Protection Relay	
FP-5000 Feeder Protection	V3-T9-155
MP-3000 Motor Protection	V3-T9-163
MP-4000 Motor Protection	V3-T9-173
EMR-3000 Motor Protection Relay	V3-T9-179
EMR-4000 Motor Protection Relay	V3-T9-191
EMR-5000 Motor Protection Relay	V3-T9-204
ETR-4000 Transformer Protection Relay	V3-T9-216
ETR-5000 Transformer Protection Relay	V3-T9-228
EGR-5000 Generation Protection Relay	V3-T9-241
Ground Fault Relay	V3-T9-254
Universal RTD Module	V3-T9-257

EDR-5000 Distribution Protection Relay

Product Description

Eaton's EDR-5000 distribution protection relay is a multi-functional, microprocessor-based relay for feeder circuits of all voltage levels. It may be used as a primary protection on feeders, mains and tie circuit breaker applications; or as backup protection for transformers, high voltage lines and differential protection. The relay is most commonly used on medium voltage switchgear applications.

The EDR-5000 distribution protection relay provides complete current, voltage, and frequency protection and metering in a single, compact case. The relay has four current inputs rated for either 5 amperes or 1 ampere and four voltage inputs. Three of the voltage inputs are to be connected to the three-phase power voltage for voltage protection and for metering. They can be connected in wye-ground or open delta configuration. The fourth voltage is for independent single-phase undervoltage/overvoltage protection, sync-check or ground protection for an ungrounded system.

The maintenance mode password protected soft key can be used for arc flash mitigation to change to an alternate settings group, set to have instantaneous elements only. The multiple setting groups can also be changed, via communications or a digital input.

An integral keypad and display is provided for direct user programming and retrieval of data without the need of a computer. 14 programmable LEDs provide quick indication of relay status.

A front port is provided for direct computer connection. An RS-485 communication port on the back is standard for local area networking using Modbus-RTU. An optional Ethernet port and protocols are available.

The EDR-5000 distribution protection relay includes programmable logic functions. Logic gates and timers may be defined and arranged for customized applications. Programmable logic control functions make the EDR-5000 relay ideally suited for main-tie-main and main 1/main 2 transfer schemes. Flash memory is used for the programming and all settings are stored in nonvolatile memory.

The relay allows for four preprogrammed setting groups which can be activated through software or contact input.

Flash memory is used for the programming and all settings are stored in nonvolatile memory. The relay allows for four preprogrammed setting groups which can be activated through software, the display or a contact input.

The EDR-5000 distribution protection relay has mass memory for data storage and a real-time clock with 1 ms time resolution. The relay will log 300 sequence of event records, 20 detailed trip logs, minimum/maximum values, load profiles, breaker wear information and oscillography data.

The EDR-5000 has eight programmable binary inputs, 2 normally opened and 8 Form C heavy-duty outputs and one form C signal alarm relay. It can be powered from 19 Vdc to 300 Vdc or 40 Vac to 250 Vac auxiliary power.

Application Description

The Eaton’s EDR-5000 distribution protection relay has been designed for maximum user flexibility and simplicity. The base relay includes all the standard current and voltage protection and metering functions.

Applications include distribution feeder protection, primary or backup protection for transformers and generators, utility interconnections and transfer schemes.

Features, Benefits and Functions

Directional Overcurrent Protection

The EDR-5000 distribution protection relay provides complete three-phase and ground directional overcurrent protection. There are 8 independent ground overcurrent elements. The ground elements “X” use the independently measured ground (or neutral) current from a separate current-sensing input. The ground elements “R” uses a calculated 3I₀ residual current obtained from the sum of the three-phase currents. This calculated current could be used for either the neutral or ground current in a three-phase, four-wire system. Each of the phase and ground overcurrent elements can be selected to operate based on fundamental or RMS current.

Phase direction is a function used to supervise all phase current elements (50, 51). A quadrature voltage is compared to a corresponding phase current to establish the direction of the fault. This function is selectable to operate in the forward, reverse or both directions. Ground direction is used to supervise ground current elements and is accomplished by using ground, negative sequence or residual currents supervised by zero, negative or positive sequence voltages or ground current. This function is selectable to operate in forward, reverse or both directions.

Voltage Restrained Overcurrent

Voltage restraint reduces the overcurrent pickup level (51P[3]). This modification of the pickup overcurrent level is compared to the corresponding phase input voltage. The EDR-5000 uses the simple linear model below to determine the effective pickup value.

Sync Check

The sync check function is provided for double-ended power source applications. The sync check monitors voltage magnitude, phase angle and slip frequency between the bus and line. It also incorporates breaker close time, dead bus dead line, dead bus live line and live bus live line features.

Reverse Power

Reverse power provides control for power flowing through a feeder. There are three elements to be configured: Operate in forward or reverse; or, under or over power conditions. Reverse power is typically applied to generator or motor applications while under power is generally applied to load or generation loss.

Reverse VARs

Reverse vars can be used to detect loss of excitation in synchronous machines. There are three elements to be configured: operate in forward or reverse; or, under or over vars conditions.

Inverse-Time Characteristics

There are 11 user-selectable inverse-time overcurrent curve characteristics. The user can select from the ANSI, IEC or thermal curve families and can select instantaneous or time delay reset characteristics.

Breaker Failure

The EDR-5000 distribution protection relay includes a breaker failure (50BF, 62BF) function that can be initiated from either an internal or external trip signal. This is an independent element that can be used to operate a lockout relay or trip an upstream breaker. The timer must be longer than the breaker operating time and the protective function reset times.

Voltage Protection

The EDR-5000 distribution protection relay has four voltage-input circuits. There is a three-phase set designated as Main Voltage (M) and a single-phase voltage circuit designated as Auxiliary Voltage (A). Both include undervoltage (27) and overvoltage (59) protection. The three-phase voltage protection can be set to operate on a single-phase, two out of three phases, or all three-phase logic. The Main VTs also provide phase voltage unbalance/reversal (47 negative sequence) protection. Each element has an independent threshold set point and adjustable time delay.

Ground Voltage Protection

In high impedance grounded systems, ground fault protection is provided by the detection of zero sequence voltage (3V₀) voltage in the neutral of the transformer by an overvoltage element (59N) connected to the secondary of the distribution grounding transformer, or in the secondary of a Wye-Broken Delta transformer used when the neutral is not accessible or in Delta system. In the EDR-5000 we can measure this zero sequence voltage through the 4th voltage input; the 59N element has to be desensitized for 3rd harmonic voltages that can be present in the system under normal operation.

Flexible Phase Rotation

The EDR-5000 distribution protection relay can be applied on either an A-B-C or A-C-B phase rotation. A user setting permits correct operation and indication of the actual system configuration.

Frequency Protection

The EDR-5000 relay provides 6 frequency elements than can be used to detect under/over frequency, rate of change, and a vector surge (decoupling of two systems) protection on the Main VT inputs. Each element has an independent threshold set point and adjustable time delay.

Autoreclosing Logic

The EDR-5000 provides a 6 shot-recloser scheme. Autoreclosing is normally used by the utilities in their distribution and transmission lines, but it can be used in commercial and industrial applications with long overhead lines. Nearly 85% of the faults that occur on overhead lines are transient in nature. Tripping of a circuit breaker normally clears a transient fault and reclosing of the circuit breaker restores power back to the circuit.

Maintenance Mode

The Maintenance Mode can improve safety by providing a simple and reliable method to reduce fault clearing time and lower incident energy levels at energized panels. The Maintenance Mode allows the user to switch to more sensitive settings via a password protected soft key, communication or via a digital Input while maintenance work is being performed at an energized panel or device. The more sensitive settings provide greater security for maintenance personnel and helps reduce the possibility of injury.

Protection Features

- Phase overcurrent elements:
 - Three instantaneous elements with timers (50P[1], 50P[2] and 50P[3])
 - Three inverse time overcurrent elements (51P[1], 51P[2] and 51P[3])
- 11 standard curves
- Instantaneous or time delay reset
- Voltage Restraint (51P[2] and 51P[3])
- Directional Control (All Elements)

- Ground overcurrent elements:
 - Two instantaneous measured elements with timers (50X[1] and 50X[2])
 - Two instantaneous calculated elements with timers (50R[1] and 50R[2])
 - Two inverse time overcurrent measured elements (51X[1] and 51X[2])
 - Two inverse time overcurrent calculated elements (51R[1] and 51R[2])
- 11 standard curves
- Instantaneous or time delay reset
- Directional control (all elements)
- Breaker failure (50BF)
- Phase unbalance negative sequence overcurrent (46[1], 46[2])
- Phase voltage unbalance and sequence protection (47[1], 47[2])
- Main three-phase under/overvoltage (27M[1], 27M[2], 59M[1], 59M[2])
- Auxiliary single-phase under/overvoltage (27A[1], 27A[2], 59A[1], 59A[2])
- Ground fault overvoltage relay (59N[1], 59N[2])
- 6 Frequency elements that can be assigned to: over frequency, under frequency, rate of change, or vector surge (81[1], 81[2], 81[3], 81[4], 81[5], 81[6])
- Apparent and displacement power factor (55A[1], 55A[2], 55D[1], 55D[2])
- Forward and Reverse Watts (32[1], 32[2], 32[3])
- Forward and Reverse VARs (32V[1], 32V[2], 32V[3])
- Sync check (25)
- Autoreclosing (79)
- Zone interlocking for bus protection (87B)
- Switch onto fault protection
- Cold load pickup

Metering Features

- Amperes: Positive, negative and zero sequence
- Ampere demand
- Volts: Positive, negative and zero sequence
- Phase angles
- Volt-amperes and VA demand
- Watts and kW demand
- kWh (forward, reverse, net)
- VARs and kVAR demand
- kVARh (lead, leg and net)
- Power factor
- Frequency
- % THD V and I
- Magnitude THD V and I
- Minimum/maximum recording.
- Sync Values
- Trending (load profile over time)

Monitoring Features

- Trip coil monitor
- Breaker wear primary and secondary (accumulated interrupted current)
- Oscillography (7200 cycles total)
- Fault data logs (up to 20 events)
- Sequence of events report (up to 300 events)
- Clock (1 ms time stamping)
- Trip cause displays fault reorder data on HMI after fault event

Control Functions

- Breaker open/close
- Remote open/close
- Programmable I/O
- Programmable Logic
- Programmable LEDs
- Multiple setting groups
- Cold load pickup
- CT supervision

Communication Features

- Local HMI
- Password protected
- Addressable
- IRIG-B
- Local communication port:
 - RS-232
- Remote communication port:
 - RS-485
 - Ethernet RJ-45
- Protocols:
 - Modbus-RTU
 - Modbus-TCP (optional)
 - IEC-61850 (optional)
- Configuration software

Monitoring and Metering

Sequence of Events Records

The EDR-5000 protection relay records a maximum of 300 events associated with the relay. An event is classified as a change of state as detected by the relay. These include relay pickups, dropouts, trips, contact closure, alarms, setting changes and self-diagnostic failures. Each event is date and time stamped to a 1 ms resolution. The events are stored in a FIFO in chronological order.

Trip Log

The EDR-5000 protection relay will store a maximum of 20 trip records in a FIFO trip log. Each trip record will be date and time stamped to a 1 ms resolution. The trip log record will include information on the type of fault, protection elements that operated, fault location and currents and voltages at the time of the fault.

PowerPort-E

PowerPort-E is the software program used to configure off-line protection setting files for all E-Series relay models. PowerPort-E is also used for

viewing measured values of the relays in real-time, uploading/downloading setting files, and retrieving event log and waveform records.

Waveform Capture (Quality Manager)

The EDR-5000 relay provides oscillographic recording capabilities. The relay will record all measured signals along with the binary signals of pickup, trip, internal logic and contact inputs. The EDR-5000 can record up to 7200 cycles of data. The number of records is proportional to the programmed size of each record; the maximum size per record is 600 cycles.

The waveform capture is initiated by up to 8 different triggers (i.e., trip/alarm events) or manually via communications or the HMI. PowerPort-E setting software is used to retrieve the records. Quality Manager is a separate software program downloaded with PowerPort-E used for analyzing the waveform and trending files retrieved from the relay.

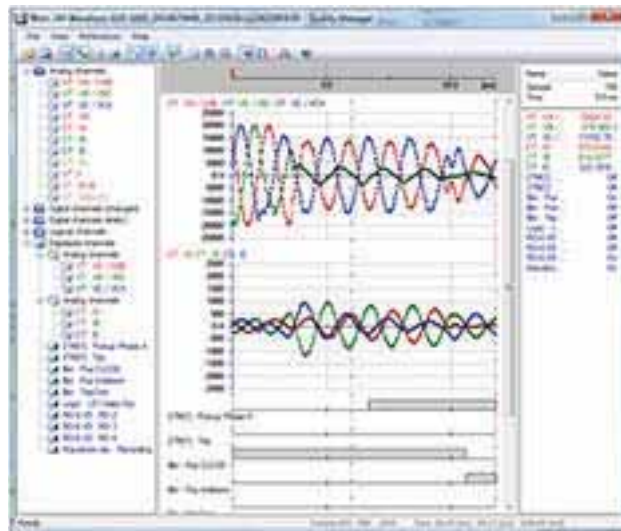

Waveform Capture (Quality Manager)

Integral User Interface

The front panel user interface has a 128 x 64 pixel LCD display with background illumination for wide angle viewing in all light conditions. 17 programmable LEDs provide quick and easy visual display of power on, mode of operation, alarm and trip indication. Soft keys are provided for operation mode selection, scrolling through data and settings. In addition, the relay settings and test functions are password protected.

Load Profiling/Trending

The EDR-5000 relay automatically records selected quantities into non-volatile memory every 5, 10, 15, 30 or 60 minutes, depending on the trending report setting.

Programmable I/O

The EDR-5000 distribution protection relay provides heavy-duty, triparted, 2 normally open and 8 Form C contacts. Two isolated inputs can be used for monitoring the trip circuit. One Form C contact is dedicated to the relay failure alarm function and is operated in a normally energized (failsafe) mode.

There are eight user-configurable discrete inputs that accept a wet contact and can operate through a wide range of power. Each input and output is user-programmable for maximum application flexibility.

Programmable Logic

The EDR-5000 distribution protection relay provides logic gates and timers that the user can customize for special or unique applications. Each gate can be assigned a logic function of either AND, OR, NAND or NOR. Each gate can have a maximum of four input signals and each input signal can be required to be a NOT. Input signals can be external inputs received via the binary inputs or internal values associated with the protection, alarm or metering set points. Each gate has a unique output assignment and designation that can be used as the input to another gate. There are 24 independent timers that have adjustable pickup and dropout delay settings.

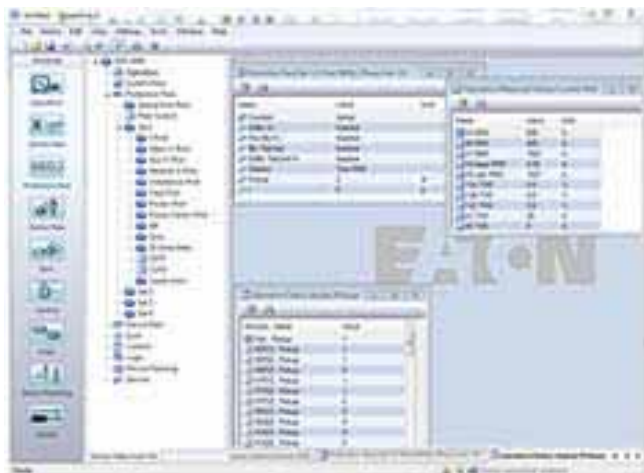

PowerPort-E

Standards and Certifications

Design Standards

- Generic Standard:
 - EN 61000-6-2
 - EN 61000-6-3
- Product Standard:
 - IEC 60255-6
 - EN 50178
 - UL 508 (Industrial Control Equipment)
 - CSA C22.2 No. 14-95 (Industrial Control Equipment)
 - ANSI C37.90
- UL-listed file: e217753

**Standards****High Voltage Tests (IEC 60255-6)**

- High frequency interference test:
 - IEC 60255-22-1 Class 3
 - Within one circuit—1 kV/2 s
 - Circuit to ground—2.5 kV/2 s
 - Circuit to circuit—2.5 kV/2 s
- Insulation voltage test:
 - IEC 60255-5, EN 50178
 - All circuits to other circuits and exposed conductive parts: 2.5 kV (eff.)/50 Hz, 1 min.
 - Except interfaces: 1.5 kV DC, 1 min.
 - Voltage measuring input: 3 kV (eff.)/50 Hz, 1 min.
- Impulse voltage test:
 - IEC 60255-5: 5 kV/0.5J, 1.2/50 μ s

EMC Immunity Tests

- Fast transient disturbance immunity test (burst):
 - IEC 60255-22-4: Power supply, mains inputs— ± 4 kV, 2.5 kHz
 - IEC 61000-4-4 Class 4: Other inputs and outputs— ± 2 kV, 5 kHz (coupling network)
 - ANSI C37.90.1: ± 4 kV, 2.5 kHz (coupling clamp)
- Surge Immunity Test:
 - IEC 61000-4-5 Class 4
 - Within one circuit—2 kV
 - Circuit to ground—4 kV
- Electrical discharge immunity test:
 - IEC 60255-22-2: Air discharge—8 kV
 - IEC 61000-4-2 Class 3: Contact discharge—6 kV
- Radiated radio frequency electromagnetic field immunity test
 - IEC 61000-4-3: 26 MHz–80 MHz—10 V/m
 - Class X: 80 MHz–1 GHz—35 V/m
 - ANSI C37.90.2: 1 GHz–3 GHz—10 V/m
- Immunity to conducted disturbances induced by radio frequency fields:
 - IEC 61000-4-6 Class 3: 10 V
- Power frequency magnetic field immunity test:
 - IEC 61000-4-8: Continuous—30 A/m
 - Class 4: 3 sec—300 A/m

EMC Emission Tests

- Radio interference suppression test:
 - IEC/CISPR11—Limit value class B
- Radio interference radiation test:
 - IEC/CISPR11—Limit value class B

Environmental Tests

Classification

- IEC 60068-1: Climatic—0/055/56
- IEC 60721-3-1:
 - Classification of ambient conditions (storage)—1K5/1B1/1C1L/1S1/1M2 but min. -13 °F (-25 °C)
- IEC 60721-3-2: Classification of ambient conditions (transportation)—2K3/2B1/2C1/2S1/2M2
- IEC 60721-3-3: Classification of ambient conditions (Stationary use at weather protected locations)—3K6/3B1/3C1/3S1/3M2 but min. 32 °F (0 °C) and 3K8H for 2 h

Test ad: Cold

- IEC 60068-2-1:
 - Temperature— -4 °F (-20 °C)
 - Test duration—16 h

Test Bd: Dry heat

- IEC 60068-2-2:
 - Temperature—131 °F (55 °C)
 - Relative humidity— $< 50\%$
 - Test duration—72 h

Test cab: Damp heat (steady state)

- IEC 60068-2-78:
 - Temperature—104 °F (40 °C)
 - Relative humidity—93%
 - Test duration—56 d

Test Db: Damp heat (cyclic)

- IEC 60068-2-30:
 - Temperature—131 °F (55 °C)
 - Relative humidity—95%
 - Cycles (12 + 12-hour)—2

Mechanical Tests**Test Fc: Vibration Response Test**

- IEC 60068-2-6, IEC 60255-21-1, Class 1:
 - Displacement: (10 Hz–59 Hz)—0.0014 in (0.035 mm)
 - Acceleration: (59 Hz–150 Hz)—0.5 gn
 - Number of cycles in each axis: 1

Test Fc: Vibration Endurance Test

- IEC 60068-2-6, IEC 60255-21-1, Class 1:
 - Acceleration: (10 Hz–150 Hz)—1.0 gn
 - Number of cycles in each axis: 20

Test Ea: Shock Test

- IEC 60068-2-27, IEC 60255-21-2, Class 1
 - Shock response test: 5 gn, 11 ms, 3 impulses in each direction
 - Shock resistance test: 15 gn, 11 ms, 3 impulses in each direction

Test Eb: Shock Endurance Test

- IEC 60068-2-29, IEC 60255-21-2, Class 1
 - Shock endurance test: 10 gn, 16 ms, 1000 impulses in each direction

Test Fe: Earthquake Test

- IEC 60068-3-3, KTA 3503, IEC 60255-21-3, Class 2
 - Single axis earthquake vibration test:
 - 3–7 Hz: Horizontal 0.394 in (10 mm), 1 cycle each axis
 - 7–35 Hz Horizontal: 2 gn, 1 cycle each axis

Catalog Number Selection

The catalog number identification chart defines the electrical characteristics and operation features included in the EDR-5000. For example, if the catalog number is EDR-5000-2A0BA1, the device would have the following:

EDR-5000

(A)–8 digital inputs, 11 output relays

(0)–5 A / 1 A phase and ground CTs, power supply range: 19–300 Vdc, 40–250 Vac

(B)–Modbus-RTU (RS-485)

(A)–Without conformal coating

(1)–Projection panel mount

Relay Removable Terminals

EDR-5000-2A 0 B A 1

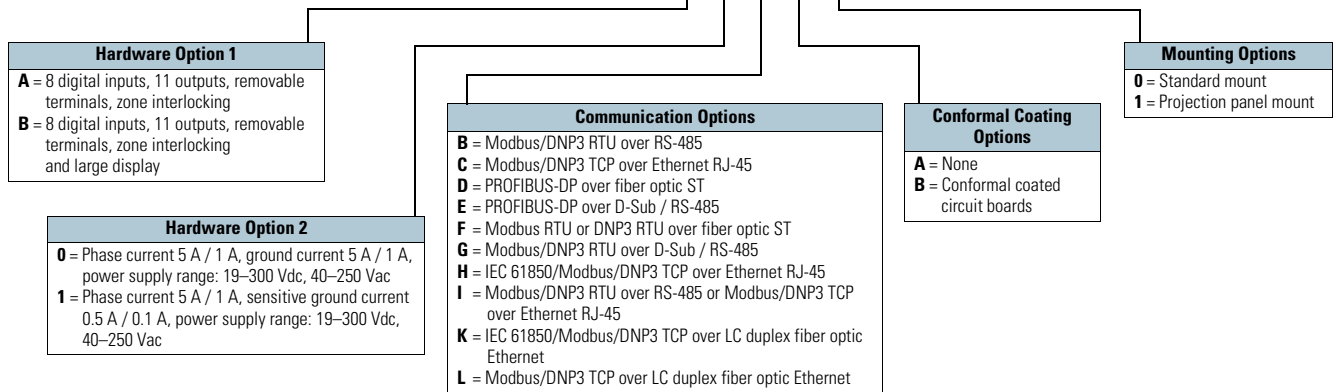

Technical Data and Specifications

Climatic Environmental Conditions

- Storage temperature: –22 °F to 158 °F (–30 °C to +70 °C)
- Operating temperature: –4 °F to 140 °F (–20 °C to +60 °C)
- Permissible humidity at ann. average: <75% rel. (on 56d up to 95% rel.)
- Permissible installation altitude:
 - 6,561.67 ft (<2000 m) above sea level
 - If 13,123.35 ft (4000 m) altitude applies, a changed classification of the operating and test voltages may be necessary

Degree of Protection EN 60529

- HMI front panel with seal: IP54
- Rear side terminals: IP20

Routine Test

- Insulation test according to IEC 60255-5: All tests to be carried out against ground and other input and output circuits
- Aux. voltage supply, digital inputs: 2.5 kV (eff.)/50 Hz
- Current measuring inputs, signal relay outputs: 2.5 kV (eff.)/50 Hz
- Voltage measuring inputs: 3.0 kV (eff.)/50 Hz
- All wire-bound communication interfaces: 1.5 kV DC

Housing

- Housing B2: Height / Width 7.205 in (183 mm) / 8.374 in (212.7 mm)
- Housing Depth (Incl. Terminals): 8.189 in (208 mm)
- Material, housing: Aluminum extruded section
- Material, front panel: Aluminum/foil front
- Mounting position: Horizontal ($\pm 45^\circ$ around the X-axis must be permitted)
- Weight: Approx. 9.259 lb (4.2 kg)

Current and Ground Current Measurement

- Nominal currents: 1 A / 5 A
- Max. measuring range:
 - Up to $40 \times I_n$ (phase currents)
 - Up to $25 \times I_n$ (ground current standard)
 - Up to $2.5 \times I_n$ (ground current sensitive)
- Continuous loading capacity: $4 \times I_n$ continuously
- Overcurrent proof:
 - $30 \times I_n/10$ s
 - $100 \times I_n/1$ s
 - $250 \times I_n/10$ ms (1 half-wave)
- Power consumption:
 - Phase current inputs
 - At $I_n = 1$ A
S = 0.15 MVA
 - At $I_n = 5$ A
S = 0.15 MVA
 - Ground current input
 - At $I_n = 1$ A
S = 0.35 MVA
 - At $I_n = 5$ A
S = 0.35 MVA
- Frequency range: 50 Hz/60 Hz $\pm 10\%$
- Terminals: Screw-type terminals with integrated short-circuiters (contacts)
- Connection cross sections:
 - $1 \times$ or 2×2.5 mm² (2 x AWG 14) with wire end ferrule
 - $1 \times$ or 2×4.0 mm² (2 x AWG 12) with ring cable sleeve or cable sleeve
 - $1 \times$ or 2×6 mm² (2 x AWG 10) with ring cable sleeve or cable sleeve
 - The current measuring board's terminal blocks may be used as with 2 (double) conductors AWG 10,12,14 otherwise with single conductors only

Plug-in Connector with Integrated Short-Circuiter (Conventional Current Inputs)

- Nominal current: 1 A and 5 A
- Continuous loading capacity: $4 \times I_n$ continuously
- Overcurrent withstand:
 - $30 \times I_n/10$ s
 - $100 \times I_n/1$ s
 - $250 \times I_n/10$ ms (1 half-wave)
- Screws: M4, captive type acc. to VDEW
- Connection cross sections:
 - $1 \times$ or 2×2.5 mm² (2 x AWG 14) with wire end ferrule
 - $1 \times$ or 2×4.0 mm² (2 x AWG 12) with ring cable sleeve or cable sleeve
 - $1 \times$ or 2×6 mm² (2 x AWG 10) with ring cable sleeve or cable sleeve
 - The current measuring board's terminal blocks may be used as with 2 (double) conductors AWG 10,12,14 otherwise with single conductors only

Control Power Supply

- Aux. voltage: 24–270 Vdc/48–230 Vac (–20/+10%)
- Buffer time in case of supply failure: ≥ 50 ms at minimal aux. voltage interrupted communication is permitted
- Maximum permissible making current:
 - 18 A peak value for <0.25 ms
 - 12 A peak value for <1 ms
- The voltage supply must be protected by a fuse of:
 - 2.5 A time-lag miniature fuse approx. 0.2 x 0.8 in (5 x 20 mm) according to IEC 60127
 - 3.5 A time-lag miniature fuse approx. 0.25 x 1.25 in (6.3 x 32 mm) according to UL 248-14

Voltage and Residual Voltage Measurement

- Nominal voltages: 100 V/110 V/230 V/400 V (can be configured)
- Max. measuring range: 2 x nominal voltage
- Continuous loading capacity: 2 x nominal voltage (800 Vac)
- Power consumption:
 - at $V_n = 100$ V
S = 0.1 MVA
 - at $V_n = 110$ V
S = 0.1 MVA
 - at $V_n = 230$ V
S = 0.4 MVA
 - at $V_n = 400$ V
S = 1.0 MVA
- Frequency range: 50 Hz or 60 Hz $\pm 10\%$
- Terminals: screw-type terminals

Frequency Measurement

- Nominal frequencies: 50 Hz / 60 Hz

Voltage Supply

- Aux. voltage: 24–270 Vdc/48–230 Vac (–20/+10%)
- Buffer time in case of supply failure: ≥ 50 ms at minimal aux. voltage communication is permitted to be interrupted
- Max. permissible making current:
 - 18 A peak value for <0.25 ms
 - 12 A peak value for <1 ms
- The voltage supply must be protected by a fuse of:
 - 2.5 A time-lag miniature fuse 5 x 20 mm (approx. 0.2 in x 0.8 in) according to IEC 60127
 - 3.5 A time-lag miniature fuse 6.3 x 32 mm (approx. 0.25 in x 1.25 in) according to UL 248-14

Power Consumption

- Power supply range: 24–270 Vdc
 - Power consumption in idle mode—7 W
 - Maximum power consumption—13 W
- Power supply range: 48–230 Vac (for frequencies of 40–70 Hz)
 - Power consumption in idle mode—7 VA
 - Maximum power consumption—13 VA

Display

- Display type: LCD with LED background illumination
- Resolution graphics display: 128 x 64 pixel
- LED-type: two colored, red/green
- Number of LEDs, housing B2: 15

Front Interface

- Baud rates: 115,200 Baud
- Handshake: RTS and CTS
- Connection: 9-pole D-sub plug

Real-Time Clock

- Running reserve of the real-time clock: 1 year min.

Digital Inputs

- Maximum input voltage: 300 Vdc/259 Vac
 - Input current: <4 mA
 - Reaction time: <20 ms
 - Fallback time: <30 ms
- (Safe state of the digital inputs)

- Four switching thresholds: $U_n = 24 \text{ Vdc}, 48 \text{ Vdc}, 60 \text{ Vdc}, 110 \text{ Vac/Vdc}, 230 \text{ Vac/Vdc}$
 - $U_n = 24 \text{ Vdc}$
 - Switching threshold 1 ON: Min. 19.2 Vdc
 - Switching threshold 1 OFF: Max. 9.6 Vdc
 - $U_n = 48 \text{ V} / 60 \text{ Vdc}$
 - Switching threshold 2 ON: Min. 42.6 Vdc
 - Switching threshold 2 OFF: Max. 21.3 Vdc
 - $U_n = 110 / 120 \text{ Vac/Vdc}$
 - Switching threshold 3 ON: Min. 88.0 Vdc / 88.0 Vac
 - Switching threshold 3 OFF: Max. 44.0 Vdc / 44.0 Vac
 - $U_n = 48–60 \text{ Vdc}$
 - Switching threshold 4 ON: Min. 184 Vdc / 184 Vac
 - Switching threshold 4 OFF: Max. 92 Vdc / 92 Vac
- Terminals: screw-type terminal

Relay Outputs

- Continuous current: 5 A AC/DC
- Maximum make current:
 - 25 A AC / 25 A DC up to 30 V for 4s
 - 30 A/230 Vac according to ANSI IEEE Std. C37.90-2005
 - 30 A/250 Vdc according to ANSI IEEE Std. C37.90-2005
- Maximum breaking current:
 - 5 A AC up to 250 Vac
 - 5 A DC up to 30 V (resistive)
 - 0.3 A DC at 300 V
- Maximum switching voltage: 250 Vac/250 Vdc
- Switching capacity: 1250 VA
- Contact type: Form C or normally open contact
- Terminals: screw-type terminals

Supervision Contact (SC)

- Continuous current: 5 A AC/DC
- Maximum switch-on current: 15 A AC / 15 A DC up to 30 V for 4 s
- Maximum breaking current:
 - 5 A Vac up to 250 Vac
 - 5 A Vdc up to 30 Vdc
 - 0.4 A at 125 Vdc
- Contact type: 1 Form C contact
- Terminals: screw-type

Time Synchronization IRIG-B00X

- Nominal input voltage: 5 V
- Connection: Screw-type terminals (twisted pair)

Zone Interlocking

- Zone Out:
 - Output voltage (High) 4.75 to 5.25 Vdc
 - Output voltage (Low) 0.0 to +0.5 Vdc
- Zone In:
 - Nominal input voltage +5 Vdc
 - Max. input voltage +5.5 Vdc
 - Switching threshold ON min. 4.0 Vdc
 - Switching threshold OFF max. 1.5 Vdc
- Galvanic isolation 2.5 kV AC (to ground and other IO)
- Connection: Screw-type terminals (twisted pair)

RS-485

- Master/slave: slave
- Connection: 6 screw-clamping terminals RM 138 MIL (3.5 mm) (terminating resistors internal)

Wiring Diagrams

Typical AC Connections—Wye VTs, 5 A CTs and Ground Current Measured by Residual Connection

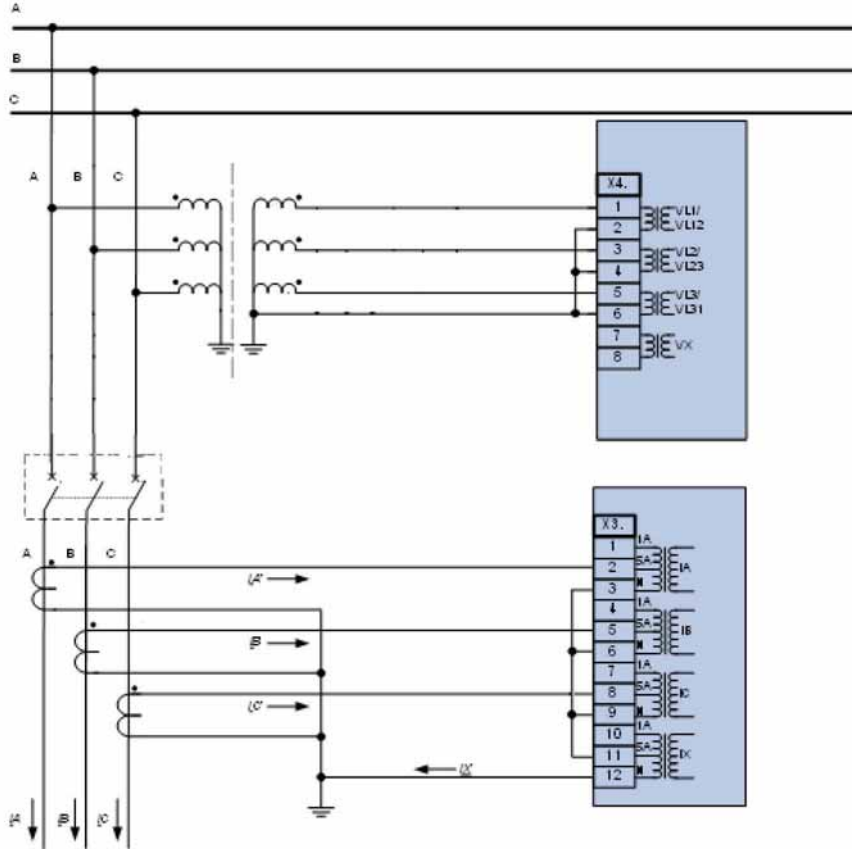

Typical One-Line Diagram

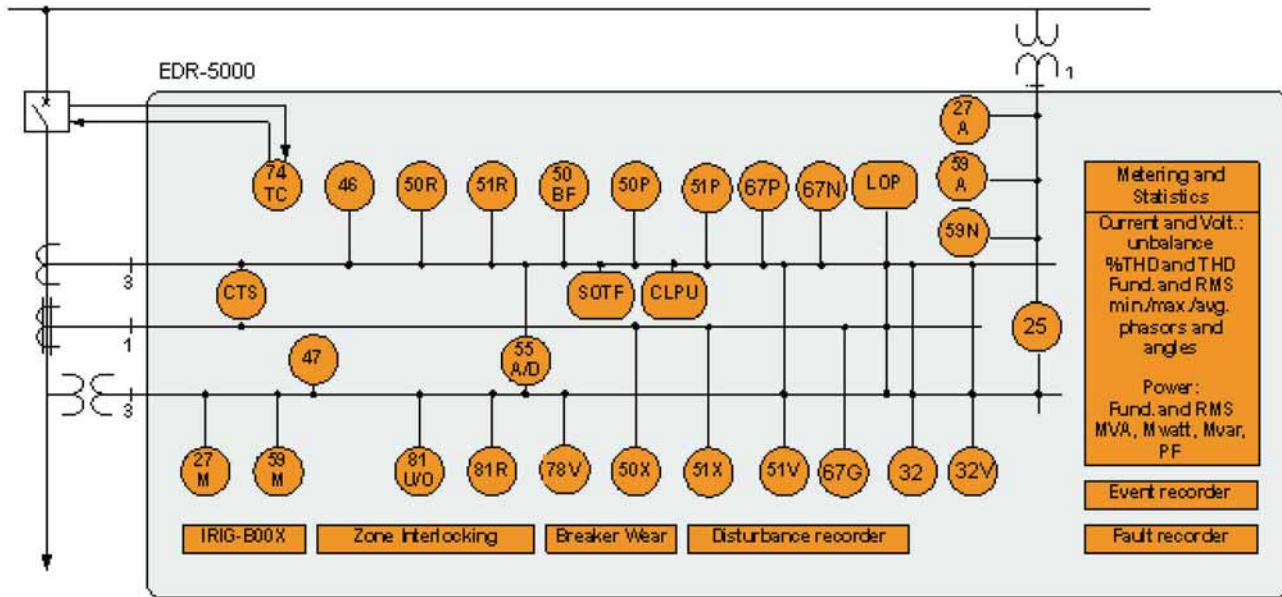

Typical Control Diagram

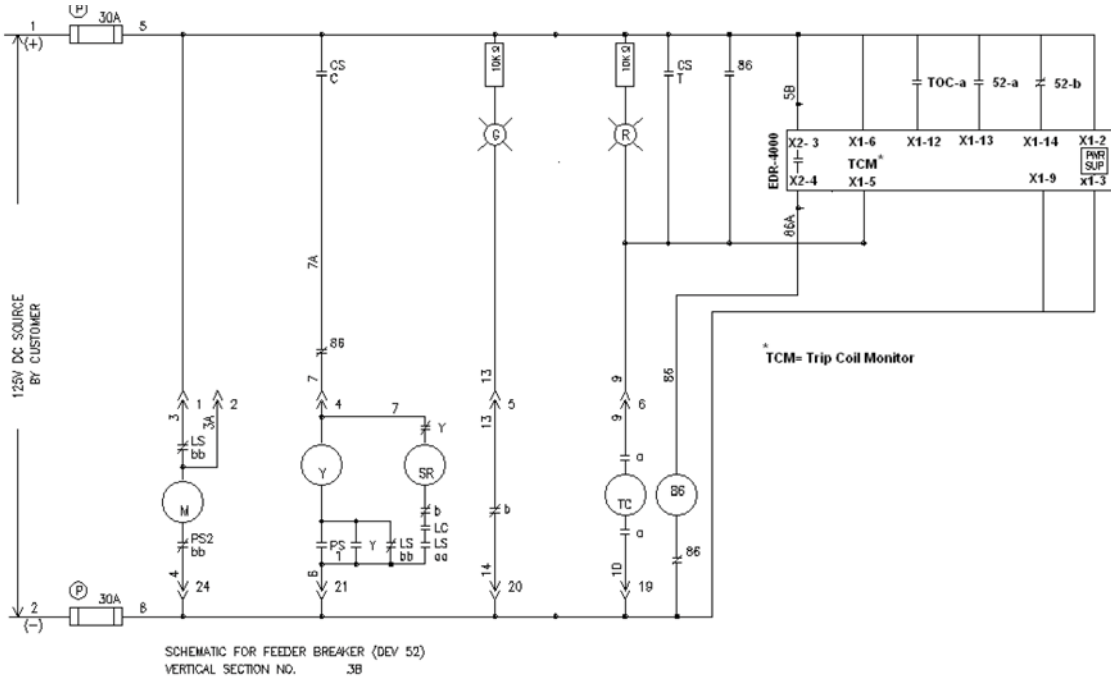

9.3

Metering Devices, Protective Relays, Software and Connectivity

Protective Relays

Approximate Dimensions in Inches (mm)

Standard Mount Front and Side Views

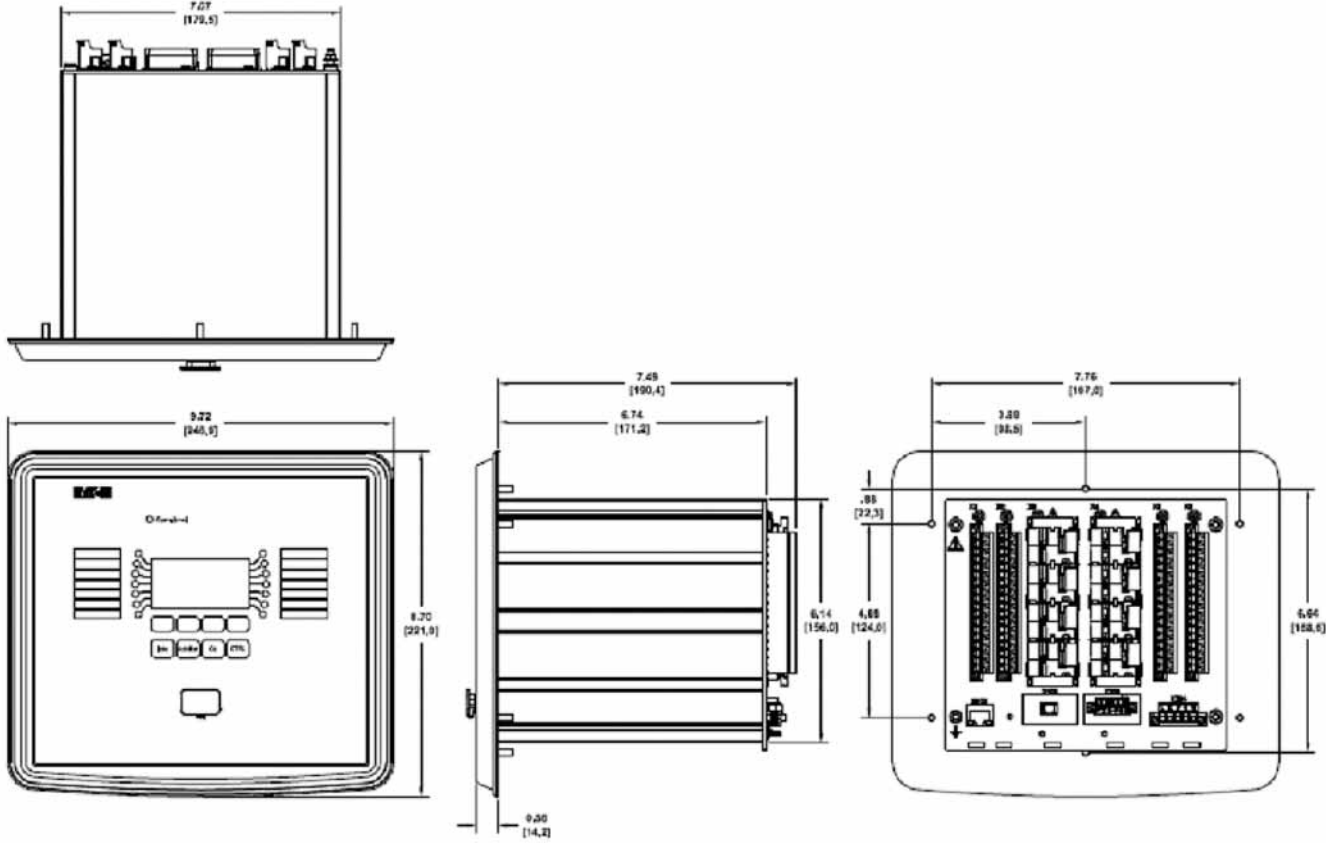

Feeder Protection FP-5000



Contents

<i>Description</i>	<i>Page</i>
Product Selection Guide	V3-T9-117
Digitrip 3000	V3-T9-123
EDR-3000 Feeder Protection	V3-T9-133
EDR-5000 Distribution Protection Relay	V3-T9-142
FP-5000 Feeder Protection	
MP-3000 Motor Protection	V3-T9-163
MP-4000 Motor Protection	V3-T9-173
EMR-3000 Motor Protection Relay	V3-T9-179
EMR-4000 Motor Protection Relay	V3-T9-191
EMR-5000 Motor Protection Relay	V3-T9-204
ETR-4000 Transformer Protection Relay	V3-T9-216
ETR-5000 Transformer Protection Relay	V3-T9-228
EGR-5000 Generation Protection Relay	V3-T9-241
Ground Fault Relay	V3-T9-254
Universal RTD Module	V3-T9-257

FP-5000 Feeder Protection

Product Description

- Microprocessor-based protection with monitoring and control for medium voltage main and feeder applications
- Current, voltage, frequency and power protection for electric power distribution systems
- Complete metering of voltage, currents, power, energy, minimum/maximum and demand functions
- Programmable logic control functions for main-tie-main transfer schemes
- Trip logs, event logs and waveform capture for better fault analysis and system restoration
- Data Logger to provide energy usage profiles for better planning, utilization and energy usage
- Compact, drawout case design
- Multiple settings groups
- ANSI, IEC and thermal protection curves for greater flexibility

Application Description

Eaton’s FP-5000 Feeder Protection relay provides complete three-phase and ground overcurrent and voltage protection plus metering in a single, compact drawout case. It may be used as primary protection on feeders, mains and tie circuit breaker applications, and as backup protection for transformers, high voltage lines and differential protection. The relay is most commonly used on medium voltage switchgear applications.

The FP-5000 takes full advantage of its microprocessor technology providing the user new freedoms and a wealth of data-gathering features. The relay performs self-checking of all major hardware and firmware protection elements to ensure their operation in the event of a system or component electrical failure or fault. Protection functions are well suited for main and distribution feeder circuit applications.

Programmable logic control functions make the FP-5000 relay ideally suited for main-tie-main and main 1/main 2 transfer schemes.

The Zone Interlocking feature can be utilized for bus protection instead of an expensive and complicated bus differential (87B) scheme. The FP-5000 works directly with Eaton’s Digitrip 3000 and Digitrip MV relays. New breaker failure logic provides faster remote backup clearing times for stuck breaker operation.

The multiple settings groups can be utilized for arc flash mitigation when an alternative setting group, set to have instantaneous elements only is activated using a selector switch and the programmable I/O in the FP-5000.

The FP-5000 provides trip and close circuit monitoring and alarming features. It continually monitors the complete trip and close circuits for continuity and readiness to trip.

Open and close pushbuttons are conveniently located on the front of the relay for local breaker operation.

Loss-of-vacuum monitoring is activated when the breaker is open. Residual current is monitored and alarmed if detected.

When an electrical fault or disturbance occurs, the FP-5000 begins to store the following in non-volatile memory:

- Voltage and current sampled data
- Calculated values
- Status of internal protection functions, logic, contact inputs and outputs

Retrieval and viewing of the data is easy, aiding in the quick analysis and restoration of your electric power system.

Features, Benefits and Functions

When the FP-5000 isn't responding to disturbances in the power system, it's providing valuable metering information at the relay and remotely. It provides energy usage and demand reading, and can alarm when usage reaches a set value. Power factor measurements can be used for cap bank switching to control kVAR demand. Onboard data trending can provide load profiles for up to 40 days.

The protection functions are listed below and shown on **Page V3-T9-160**.

- Complete protection, metering and control in a single compact case to reduce panel space, wiring and costs
 - Flexible current, voltage and frequency protection and programmability to cover a broad range of applications while simplifying relay ordering and reducing inventory
 - Integral test function reduces maintenance time and expense
 - Relay self-diagnostics and reporting improves uptime and troubleshooting
 - Breaker trip circuit monitoring improves the reliability of the breaker operation
 - Programmable logic control features that can replace and eliminate external auxiliary relays, timers and wiring
 - Zone-selective interlocking improves coordination and tripping times and saves money compared to a traditional bus differential scheme
 - Trip and event recording in non-volatile memory provides detailed information for analysis and system restoration
 - 256 cycles of waveform capture aids in post fault analysis
 - Front RS-232 port and PowerPort software provides local computer access and a user-friendly, Windows®-based interface for relay settings, and configuration and data retrieval
 - Drawout case design for quick and easy relay removal and replacement
 - Breaker open/close control from relay faceplate or remotely via communications
 - Remote communications to Eaton's PowerNet monitoring system or PC
 - Free PowerPort utility software for local PC interface to the FP-5000 for relay settings, monitoring and control
- Phase Overcurrent (Forward, Reverse or Both)**
- Two-stage instantaneous with timers (50P-1 and 50P-2)
 - Two inverse time overcurrent (51P-1 and 51P-2)
 - Directional control
 - 10 standard curves
 - Instantaneous or time delay reset
 - Voltage restrained time overcurrent (51VR)
 - Two independent ground directional overcurrent elements, one measured (IX) and one calculated (IR)
 - Two-Stage instantaneous with timers (50X-1 and 50X-2) (50R-1 and 50R-2)
 - Inverse time overcurrent (51X and 51R)
 - Ground directional polarizing (67N) $-3_{V_{0r}}$, I_{pol} , negative sequence
 - 10 standard curves
 - Instantaneous or time delay reset
 - Voltage restrained time overcurrent (51VR)
 - Breaker failure (50BF)
 - Phase unbalance negative sequence overcurrent (46-1, 46-2)
 - Phase voltage unbalance and sequence protection (47-1, 47-2)
 - Main three-phase under/overvoltage (27M-1, 27M-2, 59M-1, 59M-2)
 - Auxiliary single-phase under/over-voltage (27A-1, 27A-2, 59A-1, 59A-2)
 - Under/over frequency (81U-1, 81U-2, 81O-1, 81O-2)
 - Reverse/forward power (32-1, 32-2)
 - Sync check (25)
 - Power factor (55)
 - Zone interlocking for bus protection (87B). The FP-5000 feeder relay includes a zone selective interlocking feature that can be used with other Eaton devices like the Digitrip 3000 overcurrent relay

The FP-5000 provides the following metering functions:

- Amperes (rms, phasor and sequence)
- Amperes demand and peak demand
- Volts (rms, phasor and sequence)
- VA and VA demand
- Watts and kW demand and peak demand
- Forward/reverse/net kWh
- VARs and kVAR demand and peak demand
- Lead/lag/net kVARh
- Power factor
- Frequency
- Voltage and current
- %THD and magnitude THD
- Minimum/maximum recording with date/time stamp
- Trending (load profile over time)

The FP-5000 provides the following monitoring and data recording functions that enhance the security of the protection system and provides useful information for scheduling maintenance:

- Trip circuit monitoring
- Close circuit monitoring
- Loss-of-vacuum monitoring
- Breaker wear (accumulated interrupted current)

- Waveform capture (256 cycles total, up to 16 events)
- Fault data logs (up to 16 events)
- Sequence of events report (up to 100 events)
- Clock

The FP-5000 provides standard control functions plus user-configurable custom control capabilities. This logic can be used for applications such as main-tie-main transfer schemes.

- Remote open/close
- Programmable I/O
- Programmable logic gates and timers
- Multiple setting groups (up to four)
- Bus transfer logic
- Cold load pickup
- Loss of potential (PT blown fuses)

The FP-5000 supports the following communication options:

- Local HMI
- Password protected
- Addressable
- Local communication port
- Remote communication port:
 - FSK
 - RS-232
 - RS-485
- Protocols:
 - INCOM
 - Modbus
- Configuration software

Communication Software

Eaton provides two types of communication software. The first is PowerPort. It runs on a PC or laptop for easy access to a single relay to change set points or configuration and to view metered values and stored data. PowerPort is free and can be downloaded from www.eaton.com; search for 'PowerPort,' then click the download search result.

The second package is PowerNet. PowerNet is a power management software package that is designed for continuous, remote monitoring of many devices. It provides all the functionality of PowerPort plus additional functions such as billing, trending and graphics. Contact your local Eaton representative for more information on PowerNet software.

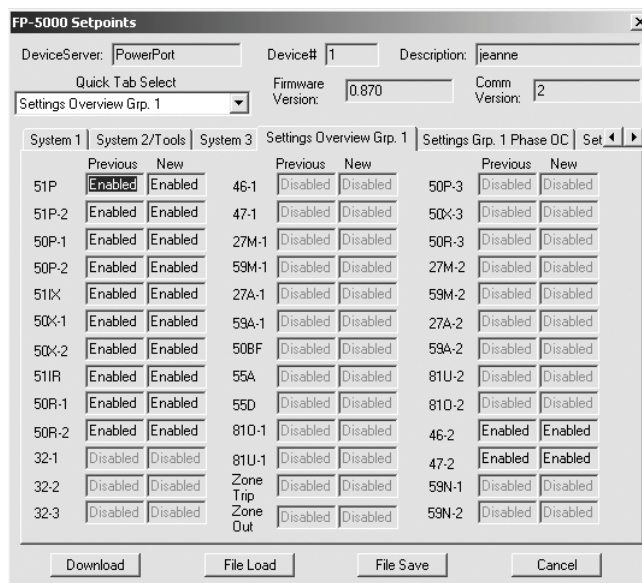

PowerPort and PowerNet Protection Overview Screen

Standards and Certifications

- Meets ANSI, CE and CSA standards

Compliance

- UL Recognized, File # E154862
- UL 1053 (1994) recognized
- ANSI C37.90 (1989)
- EN 55011 (1991)
- EN 61000-6-2 (1999)

Emission Tests

- EN 55011 (1991)—Group 1 Class A (CISPR-11, Class A)
- FCC 47 CFR Chapter 1—Part 15 Subpart b Class A

Immunity Tests

- ANSI C37.90.1 (1989)—Surge Withstand Capability
- ANSI C37.90.2 (1995)—EMI Immunity to 35V/m
- EN 61000-4-2 (1995)—ESD Rating of 8 kV
- EN 61000-4-3 (1997)—Radiated EM Field at 10V/m
- EN 61000-4-4 (1995)—Fast Transient Burst at 2 kV
- EN 61000-4-5 (1995)—Surge Immunity Test
- EN 61000-4-6 (1996)—Conducted RF at 10V/m
- EN 61000-4-11 (1994)—Voltage Dips and Variations
- EN 61000-4-8—Power Frequency Magnetic Field Immunity



Catalog Number Selection

FP-5000 Feeder Protection

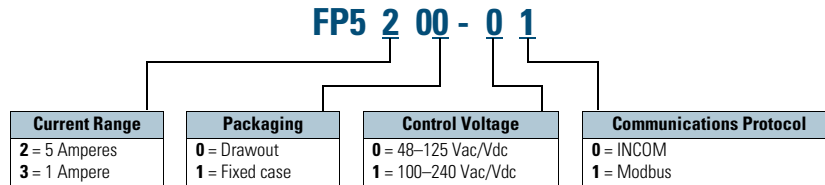

Technical Data and Specifications

Control Power

- Control voltage:
 - 48–125 Vac/Vdc
 - 100–240 Vac/Vdc
- Operating voltage:
 - 55–264 Vac
 - 38–300 Vdc
- Interruption ride-through time: 20 cycle interruption of nominal ac supply
- Power consumption: 20 VA maximum

Current Inputs

- Nominal (I_n): 1 A or 5 A
- CT rating:
 - 2 x I_n continuous
 - 80 x I_n for 1 second
- CT burdens:
 - < 0.25 VA at 5 A (nominal)
 - < 0.05 VA at 1 A (nominal)

Voltage Transformer Inputs

- Nominal: 120 Vac
- Operating range: 69–150 Vac
- Burden:
 - <0.015 at 120 Vac
 - 1 megaohm

Metering Accuracy

- Phase current:
 - ±0.5% or ±0.025 A from 0.02–20 per unit fully offset current waveform
- Ground current:
 - ±0.5% of full scale (I_n) from 0.02–2.0 per unit fully offset current waveform
- Phase voltage: ±0.5% or ±0.2V from 0–160 Vac
- Frequency measurement accuracy: ±0.02 Hz
- Phase angle: ±1 °C
- Power metering accuracy: ±1.5%
- Metering accuracy temperature range: 32 °F to 122 °F (0 °C to 50 °C)
- Temperature range: ±5% for operation below 32 °F (0 °C) and above 122 °F (50 °C)
- Relay outputs:
 - 2 Form C, NO and NC
 - 5 Form A, NO only

- Input signal frequency necessary for accurate operation:
 - 60 Hz nominal, 57–63 Hz (±5%)
 - 50 Hz nominal, 47–53 Hz (±5%)
- Clock accuracy:
 - Free running ±1 minute/month at 25 °C
 - Clock automatically updated by PowerNet host when present

Protective Functions

Phase and Ground Overcurrent Protection

- Inverse characteristics: Mod, Very, Extremely, IECA, IECB, IECC, It, I²t, I⁴t, Flat
- TOC (51) pickup range: 0.1–4.0 per unit in 0.01 steps
- Time multipliers: 0.05–10.0 in 0.01 steps
- IOC (50) pickup range: 0.1–20.0 per unit in 0.01 steps
- Pickup accuracy: ±1% (at 0.1–2 per unit)
- Time delay: 0–9999 cycles in 1 cycle steps
- Time accuracy: ±3% or ±30 ms
- Directional (67, 67N, 67G): forward, reverse or both

Voltage Unbalance (47)

- Threshold (minimum voltage) 1–100 volts in 1 volt steps
- % V2/V1: 4–40% in 1% steps
- Time delay: 0–9999 cycles in 1 cycle steps

Current Unbalance

- Threshold (minimum current) 0.1–20.0 per unit in 0.01 steps
- % I2/I1: 4–40% in 1% steps
- Time delay: 0–9999 cycles in 1 cycle steps

Under/Overtension Protection

- Pickup range: 10–150 volts in 1 volt steps
- Time delay: 0–9999 cycles in 1 cycle steps

Under/Over Frequency Protection

- Pickup range: 45–65 Hz in 0.01 Hz steps
- Time delay: 0–9999 cycles in 1 cycle steps

Breaker Failure Protection

- Pickup range: 0.1–5.0 per unit in 0.01 steps
- Time delay: 0–9999 cycles in 1 cycle steps

Power Protection (32)

- Forward/reverse: over/under
- Pickup accuracy: ±1.0%
- Trip time accuracy: 0 to 12 cycles or 0.1%, whichever is greater

Sync Check (25)

- Phase angle: 1 to 60 °C
- Slip frequency: 0.1 to 2 Hz
- Voltage differential: 1 to 100 volts
- Breaker close time: 0 to 9999 cycles

Power Factor

- Trigger/reset threshold: 0.5 lag to 0.5 lead in 0.01 steps
- Time delay: 0–1000 seconds in 1 second steps

Discrete Inputs

- Number of contact inputs: 8
- Rating: 48 Vdc wetting voltage provided with internal ground only

Output Contacts

- Number of output contacts: Five Form A and two Form C

Rating of Output Contacts

- Momentary:
 - Make 30 A AC/DC for 0.25 seconds
 - Break 0.25 A at 250 Vdc (resistive)
 - Break 5 A at 120/240 Vac
- Continuous:
 - 5 A at 120/240 Vac
 - 5 A at 30 Vdc

Logic and Control Functions

- Six programmable logic gates for AND, OR, NAND, NOR operation
- Two latching (flip/flop) gates
- Six timer gates provide on/off delays

INCOM Communications

- Baud rate: 9600 fixed
- Maximum distance: 10,000 feet (3048 m)
- Protocol: INCOM

RS-485 Communications, Rear Panel

- Baud rate: 19.2 K, 9.6 K
- Protocol: Modbus RTU

RS-232 Communications, Front Panel

- Baud rate: 38.4 K, 19.2 K, 9.6 K
- Connector standard 9-pin subminiature, three-wire
- Protocol: INCOM

Environmental Ratings

- Operating temperature: –0 °F to +140 °F (–40 °C to +60 °C) Product tested to +185 °F (+85 °C)
- Storage temperature: –40 °F to +185 °F (–40 °C to +85 °C)
- Humidity: 5–95% relative humidity (noncondensing)
- Altitude: 0–6350 feet (0–1935 m) above Mean Sea Level

Wiring Diagrams

FP-5000 One-Line Drawing

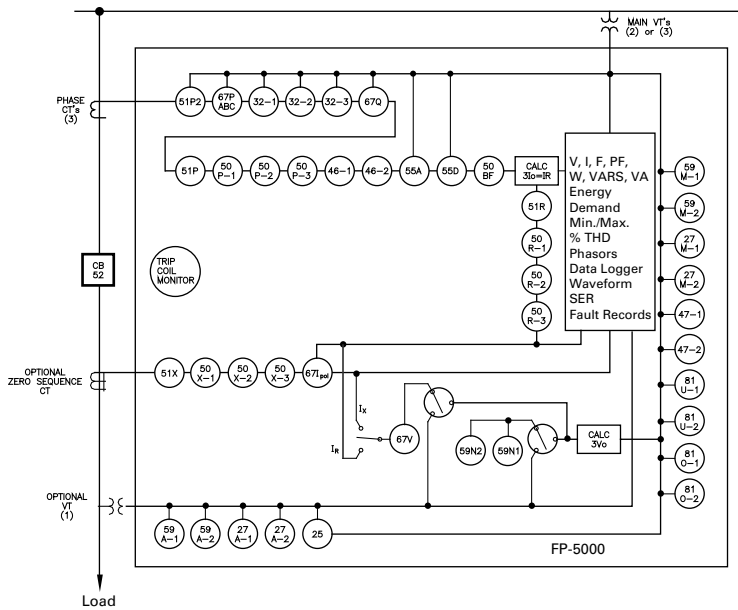

FP-5000 Rear View and Terminal Designations

TB1		TB2	
101	Power Supply Input (+)	201	C In 1
102	Power Supply Input (-)	202	C In 2
103	RLY Healthy Com.	203	C In 3
104	RLY Healthy N.O.	204	C In 4
105	RLY Healthy N.C.	205	C In Source 1
106	Alarm Com.	206	C In 5
107	Alarm N.O.	207	C In 6
108	Alarm N.C.	208	C In 7
109	RLY 5 Com.	209	C In 8
110	RLY 5 N.O.	210	C In Source 2
111	RLY 4 Com.	211	Not Used
112	RLY 4 N.O.	212	Not Used
113	RLY 3 Com.	213	VA(+) Main
114	RLY 3 N.O.	214	VB(+) Main
115	Trip 2 Com.	215	VC(+) Main
116	Trip 2 N.O.	216	Vx1 Aux
117	Trip 1 Com.	217	Vx2 Aux
118	Trip 1 N.O.	218	Vg Main

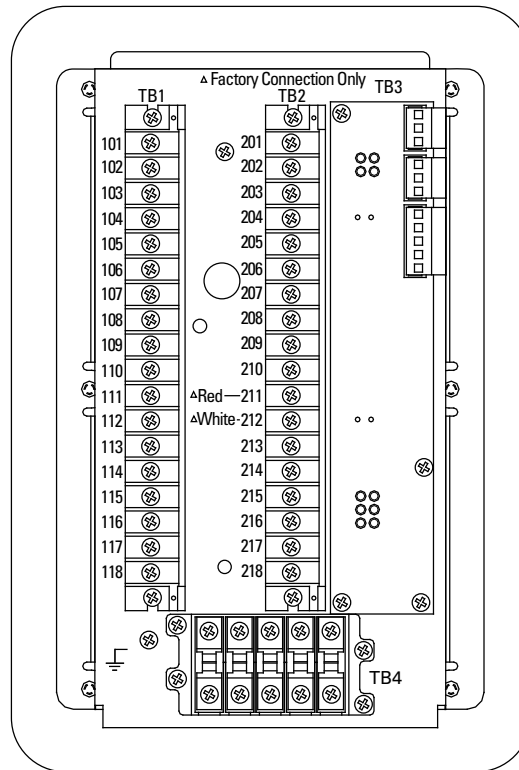

TB3	
J1-1	PowerNet
J1-2	PowerNet
J1-3	PowerNet Shield
J2-1	Accessory Bus
J2-2	Accessory Bus
J2-3	Accessory Bus Shield
J3-1	Zone Out
J3-2	Zone Com.
J3-3	Zone Shield
J3-4	Zone In
J3-5	Zone Com.
J4-1	
J4-2	
J4-3	
J5-1	RS485(+)
J5-2	RS485(-)
J5-3	RS485com
J5-4	RS485shield

A1 B1 C1 X1 N.C. 1
A2 B2 C2 X2 N.C. 2

FP-5000 Typical Connection Drawing Using Wye PTs

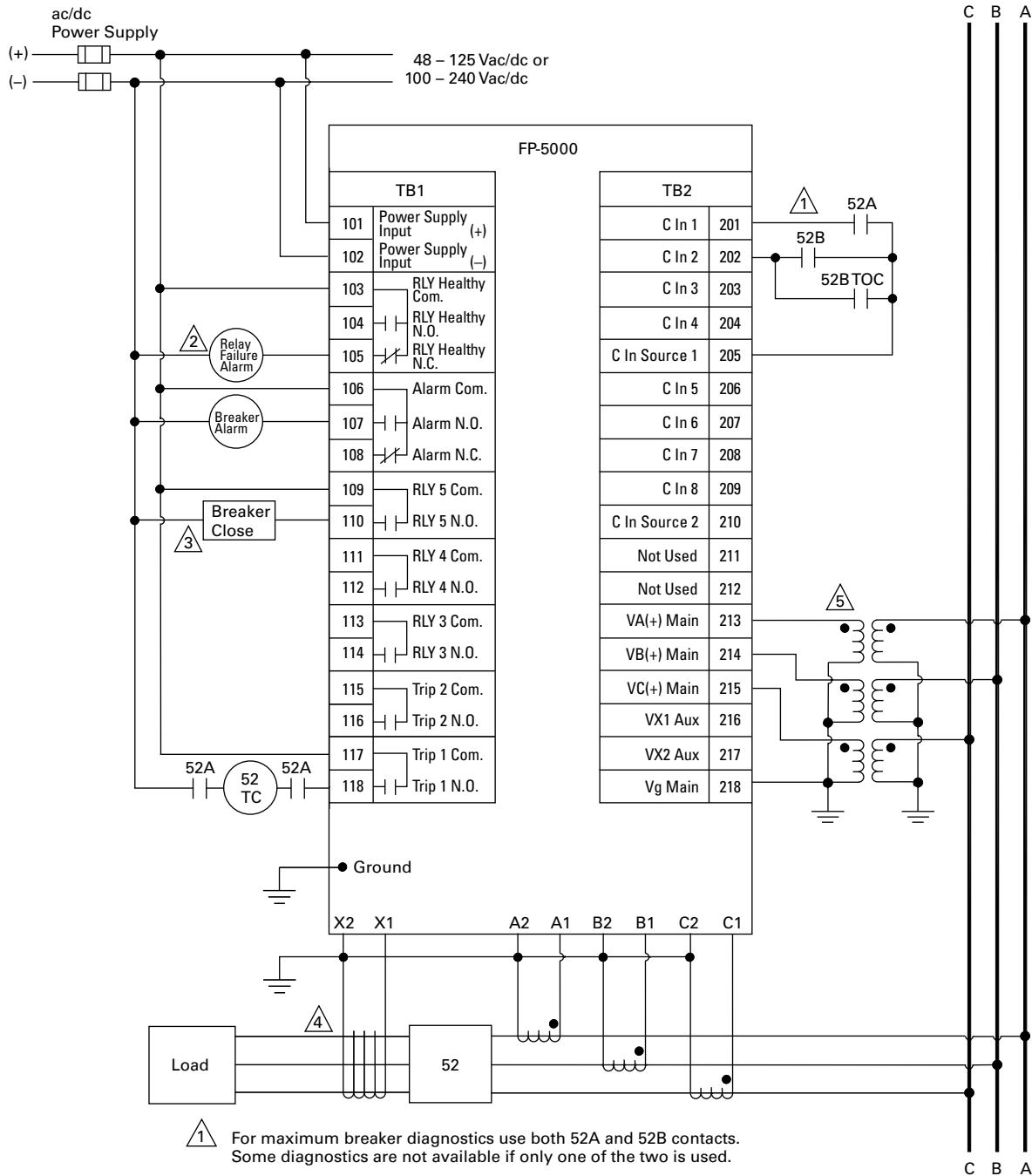

- 1 For maximum breaker diagnostics use both 52A and 52B contacts. Some diagnostics are not available if only one of the two is used.
- 2 A relay failure alarm should provide immediate attention as circuit is no longer protected. Relay failure output is normally energized.
- 3 FP-5000 can initiate a breaker close via the front panel interface and/or remote activation through communication or discrete input.
- 4 Residual connection may be used in place of zero sequence CT.
- 5 Delta or open delta PT connection may be used in place of wye-ground connection.

FP-5000 Front View and Drawout Case Side View

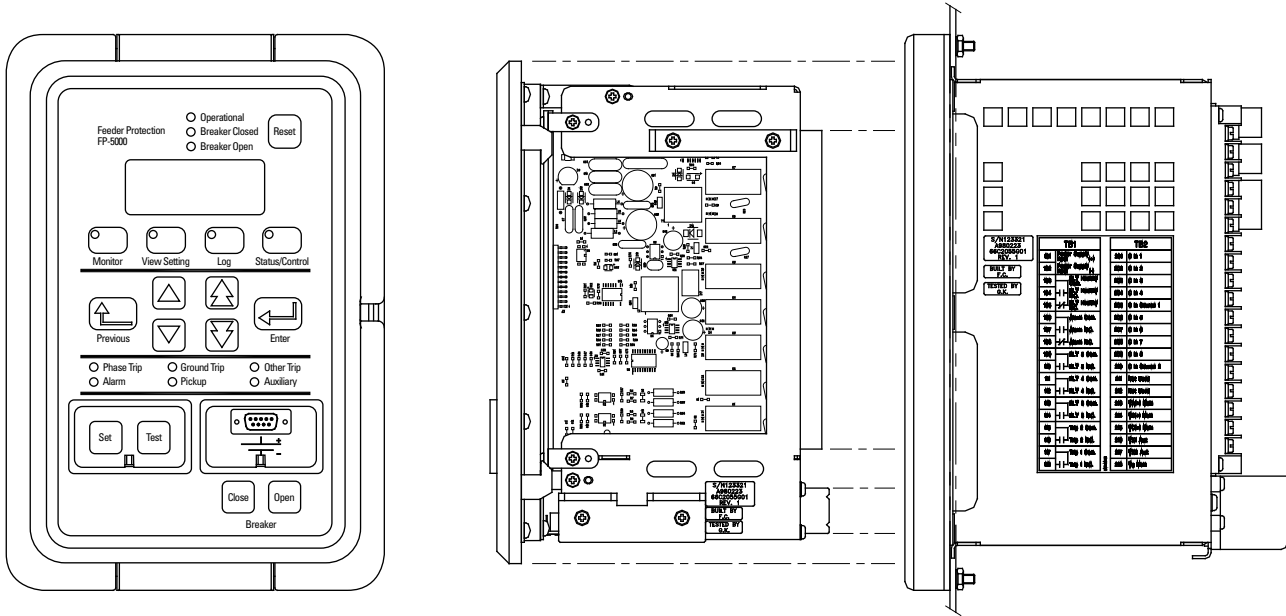

Dimensions

Approximate Dimensions in Inches (mm)

FP-5000 Feeder Protection Relay

Height	Width	Depth	Shipping Weight Lbs (kg)
In Front of Panel			
11.34 (288.0)	7.72 (196.1)	0.80 (20.3)	12.5 (5.7)
Behind Panel			
6.70 (170.2)	5.30 (134.6)	6.90 (175.3)	12.5 (5.7)

MP-3000



Contents

<i>Description</i>	<i>Page</i>
Product Selection Guide	V3-T9-117
Digitrip 3000	V3-T9-123
EDR-3000 Feeder Protection	V3-T9-133
EDR-5000 Distribution Protection Relay	V3-T9-142
FP-5000 Feeder Protection	V3-T9-155
MP-3000 Motor Protection	
MP-4000 Motor Protection	V3-T9-173
EMR-3000 Motor Protection Relay	V3-T9-179
EMR-4000 Motor Protection Relay	V3-T9-191
EMR-5000 Motor Protection Relay	V3-T9-204
ETR-4000 Transformer Protection Relay	V3-T9-216
ETR-5000 Transformer Protection Relay	V3-T9-228
EGR-5000 Generation Protection Relay	V3-T9-241
Ground Fault Relay	V3-T9-254
Universal RTD Module	V3-T9-257

MP-3000 Motor Protection

Product Description

- Microprocessor-based, multi-function motor protection
- Current only device—no need to add PTs
- Intel-I-Trip™ overload protection based on motor data
- Event recording and operational logging
- Motor Start Profile™
- Optional Quick Release Drawout Case
- Used on AMPGARD® and medium voltage assemblies
- “Help” menu provides user operational assistance

Application Description

Eaton’s MP-3000 motor protection relay is a multifunctional microprocessor-based protective relay for the protection of three-phase AC motors. The MP-3000 motor relay may be applied to any size motor at any voltage level. It is most commonly used on large, medium voltage three-phase induction motors. It has also been widely used on important low voltage (480 volt) motor applications and synchronous motors.

The MP-3000 motor relay is a current only device that monitors three-phase and ground currents. It provides motor overload, stall, short circuit, phase unbalance, single phasing and ground fault motor protection.

It can also be used to provide protection for a load jam or loss of load condition. Please refer to **Page V3-T9-167**.

The MP-3000 motor relay provides start control logic to protect the motor against excessive starts or starting the motor before it has had sufficient time to cool down. The MP-3000 motor relay may be applied to either across the line starters or reduced voltage starters. On reduced voltage starters, the MP-3000 relay can control the switch from reduced voltage to full voltage based on time and/or motor transition. The MP-3000 can protect the starter against failure to transition to full voltage through contact feedback and an incomplete sequence function.

The MP-3000 motor relay is generally used on a motor starter or a breaker used for a motor load. The MP-3000 motor relay provides the intelligence to protect and control the motor against abnormal operating conditions. It monitors the currents from either a 5 A or 1 A secondary of a CT circuit. Ground current may be obtained from either a ground CT or from the residual connection of the phase CTs. It provides a Form C contact output for controlling the starter contacts or breaker operation.

Features, Benefits and Functions

- Complete motor protection and control in a single compact case reduces panel space requirements and wiring costs
- Microprocessor design with self diagnostics eliminates calibration and reduces installation, commissioning and maintenance
- Programmable stop 2–20% of PCT
- Intel-I-Trip overload protection develops customized curve from manufacturer's supplied motor data
- Intel-I-Trip overload protection provides adaptive trip characteristics based on motor temperature when motor RTDs are connected through an optional URTD module
- Meets UL 1053 ground fault protection standards that eliminates the need for a separate ground relay saving cost, space, wiring and time
- Voltage dip/loss ride through capability reduces unnecessary trips caused by poor power quality
- Motor currents, temperatures and conditions are monitored and displayed either locally or remotely
- Event log provides motor operating records for the most recent 20 Trip or Alarm events with date and time stamping. This information can improve troubleshooting and reduce downtime
- Log book records the most recent 100 events such as motor START/STOP and set point changes to provide a log of motor operation with date and time stamping
- RTD diagnostics reduces unnecessary tripping caused by faulty RTD, RTD wiring or communications
- Arm/Disarm feature improves security for critical motor applications
- Motor Start profile verifies protection and motor starting coordination. This feature can be used to develop protection settings on old motors where data is not available
- Optional communication module and Eaton's software simplifies setting, configuration, monitoring, commissioning and data retrieval either locally or remotely
- Optional Quick Release Drawout Case construction simplifies relay removal and replacement

The protection functions are listed below.

- I^2t overload protection (49/51)
- Locked rotor (49S/51)
- Ultimate trip current (51)
- Negative sequence phase unbalance (46)
- Instantaneous overcurrent (50)
- Ground fault protection (50G)
- RTD trip and alarm with URTD module (49/38)
- Underload trip (37)
- Starts per time (66)
- Jam or stall (51R)
- Auto or manual reset (86)
- Fail-safe or non-fail-safe trip modes

The metering functions are:

- Motor currents:
 - Average current (Iave)
 - Individual phase and ground current in primary amperes
 - Percent of full load
 - Percent of phase unbalance
- RTD temperatures:
 - Individual winding
 - Motor bearing
 - Load
 - Auxiliary temperatures
- Motor conditions:
 - Percent of I^2t thermal bucket
 - Time before start
 - Remaining starts allowed
 - Oldest start time

Standards and Certifications

The MP-3000 motor protection was designed to meet the industry standards for protective relays. It is recognized under UL 1053 Ground Fault Protection Standard.

- UL recognized (File No. E154862)
- UL 1053 recognized
- UL 508 recognized
- ANSI C37.90, C37.90.1
- cUL
- CSA



Product Selection

MP-3000



MP-3000

Description	Catalog Number
MP-3000 Drawout, 5 A with RS-232	MP3011
MP-3000 Drawout, INCOM, 5 A with RS-232	MP3012
MP-3000 Drawout, Modbus, 5 A with RS-232	MP3013
MP-3000 Drawout, DeviceNet, 5 A with RS-232	MP3014
MP-3000 Drawout, 1 A with RS-232	MP3111
MP-3000 Drawout, INCOM, 1 A with RS-232	MP3112
MP-3000 Drawout, Modbus, 1 A with RS-232	MP3113
MP-3000 Drawout, DeviceNet, 1 A with RS-232	MP3114
MP-3000 Fixed Case, 5 A with RS-232	MP3010
MP-3000 Fixed Case, INCOM, 5 A with RS-232	MP3010-INCOM
MP-3000 Fixed Case, Modbus, 5 A with RS-232	MP3010MODBUS
MP-3000 Fixed Case, DeviceNet, 5 A with RS-232	MP3010DEVICEN
MP-3000 Fixed Case, 1 A with RS-232	MP3110
MP-3000 Fixed Case, INCOM, 1 A with RS-232	MP3110-INCOM
MP-3000 Fixed Case, Modbus, 1 A with RS-232	MP3110MODBUS
MP-3000 Fixed Case, DeviceNet, 1 A with RS-232	MP3110DEVICEN
MP-3000 Fixed Case, INCOM, 5 A with RS-232, URTD	MP3010VPI
MP-3000 Fixed Case, Modbus, 5 A with RS-232, URTD	MP3010VPM
MP-3000 Fixed Case, DeviceNet, 5 A with RS-232, URTD	MP3010VPD
MP-3000 Fixed Case, INCOM, 1 A with RS-232, URTD	MP3110VPI
MP-3000 Fixed Case, Modbus, 1 A with RS-232, URTD	MP3110VPM
MP-3000 Fixed Case, DeviceNet, 1 A with RS-232, URTD	MP3110VPD

Options and Accessories

Additional Related Products by Eaton's Cutler-Hammer® Series

The MP-3000 is available in either a fixed mount or Quick Release Drawout Case. Both mountings use the same panel cutout. **Page V3-T9-170** shows cutout dimensions. **Page V3-T9-167** shows a typical fixed mount wiring diagram for a medium voltage motor starter application. **Page V3-T9-168** shows the fixed mount terminal designation. **Page V3-T9-170** shows the drawout case panel mounting, and shows the drawout case terminal designation.

The Universal RTD module (URTD) is required when the motor is equipped with RTDs that you wish to monitor and use for protection. The URTD can be mounted near the motor to reduce RTD wiring and costs. **Page V3-T9-169** shows MP-3000 and URTD inter-connection wiring. Please refer to the URTD information described elsewhere in this catalog.

The MP-3000 motor protection is designed to operate from 120 Vac or 240 Vac auxiliary control power. The MP-3000 motor relay can be used with DC control power with the addition of the IQDCPS. The IQDCPS is an inverter from DC to AC.

Technical Data and Specifications**Control Power**

- Nominal rating:
 - 120 Vac or 240 Vac
 - +10%, -25%
- Operating range:
 - 120 Vac: 90 132 Vac
 - 240 Vac: 180 264 Vac
- Frequency: 50 or 60 Hz
- Power use:
 - 20 VA maximum
 - URTD: 6 VA maximum
 - IPONI: 1 VA maximum
- Ride-through time: 30 cycles from nominal Vac

Current Inputs

- Nominal (I_n): 1 A or 5 A
- CT rating:
 - $2 \times I_n$ continuous
 - $50 \times I_n$ for 1 second
- Burdens:
 - < 0.25 VA at 5 A
 - < 0.05 VA at 1 A

Metering Accuracy

- Phase current: $\pm 1\%$ of I_n (5–100%)
- Ground current: $\pm 1.5\%$ of I_n (0–55%)

Discrete Inputs

- Number of inputs: two programmable
- Ratings:
 - 1.2 VA at 120 Vac
 - Maximum off = 36 Vac
 - Minimum on = 86 Vac

Output Contacts

- Number of outputs: four Form C, programmable
- Momentary:
 - Make 30 A AC/DC for 0.25 seconds
 - Break 0.25 A at 250 Vdc (resistive)
 - Break 5 A at 120 240 Vac
- Continuous:
 - 5 A at 120/240 Vac
 - 5 A at 30 Vdc

Analog Output

- Rating: ± 4 –20 mA programmable
- Maximum load: 1K ohm
- Accuracy: 1%

Motor Overload Protection (I^2t)

- Full load amperes: 10–3000 A
- Locked rotor current: 300–1200% FLA
- Locked rotor time: 1–120 seconds
- Ultimate trip current: 85–150% FLA
- Phase CT ratio: 10–4000 (I_n)
- Ground CT ratio: 10–4000 (I_n)
- Timing accuracy: $\pm 2.5\%$ or ± 30 ms for $I > 1.1 \times U.T.C$

Trip Setting Range

- Ground fault (GF): Off, 2–55% CT ratio
- GF start time delay: 2–60 cycles
- GF run time delay: 0–60 cycles
- Timer accuracy: ± 20 ms
- Instantaneous O.C.: Off, 300–1600% FLA
- IOC start time delay: 2–60 cycles
- Timer accuracy: ± 20 ms
- JAM trip: Off, 100–1200% FLA
- Underload trip: Off, 1–90% FLA
- Phase unbalance trip: Off, 4–40% I_{neg}/I_{pos}
- Start delay timers:
 - 0–120 seconds (underload and phase unbalance)
 - 0–1200 seconds (jam)
- Run delay timers: 0–240 seconds
- Timer accuracy: $\pm 0.5\%$ +100 ms

Alarm Setting Range

- Ground fault: Off, 2–55% CT ratio
- Overload I^2t : Off, 60–99% I^2t
- JAM: Off, 100–1200% FLA
- Underload: Off, 1–90% FLA
- Phase unbalance: Off, 4–40% I_{neg}/I_{pos}
- Run delay timers: 0–240 seconds

Start Control Functions

- Starts per time: 1–10 starts
- Time for starts per time: Off, 1–240 minutes
- Time between starts: Off, 1–240 minutes
- Number of cold starts: 1–5 starts
- Motor transition current: 10–300% FLA
- Time for transition: 0–1200 seconds
- Inc. sequence timer: Off, 1–240 seconds
- Long acceleration timer: Off, 1–1200 seconds
- Anti-Backspin timer: Off, 1–3600 minutes

RTD Inputs (Requires URTD module)

- Sensor types:
 - 10 ohm copper
 - 100 ohm nickel
 - 120 ohm nickel
 - 100 ohm platinum

URTD Module Communications

- Interface:
 - Electrical (three-wire)
 - Fiber optic (preferred)
- Fiber optic cable: Type HBFR-ERS or EUS

Clock

- Accuracy: ± 1 minute/month at 77 °F (25 °C)

IPONI Communications

- Type: two-wire, FSK
- Baud rate: 1200 or 9600 baud
- Protocol: INCOM
- Functions:
 - Read/write set points
 - Read metered values
 - Read trip/alarms
 - Read events/history
 - View starting profile

MPONI Communications

- Type: 5-wire, 485
- Baud rate: 1200 or 9600 baud
- Protocol: Modbus RTU
- Functions:
 - Read/write set points
 - Read metered values
 - Read trip/alarms
 - Read events/history
 - View starting profile

DPONI Communications

- Type: J-wire
- Baud rate: 500 k, 250 k, 125 k
- Protocol: DeviceNet
- Functions:
 - Read metered values
 - Read trip/alarms

Logging

- Log book: 100 events
- Log event: 20 trips and alarms
- Log start: last four starts
- Start profile: last four starts (communication only)
- History records: motor, trips, alarms and total records

Environmental Conditions

- Operating temperature: -4 °F to 140 °F (-20 °C to +60 °C)
- Storage temperature: -49 °F to +185 °F (-45 °C to +85 °C)
 - Humidity: 0–95% noncondensing

Wiring Diagrams

MP-3000 Motor Relay Protection Functions

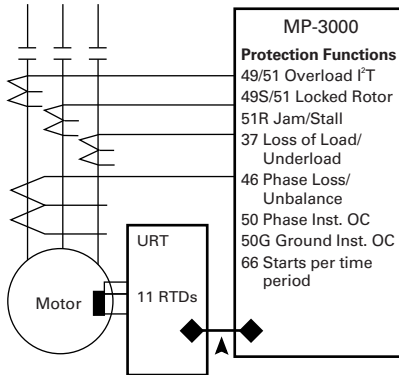

MP-3000 Fixed Mount Typical

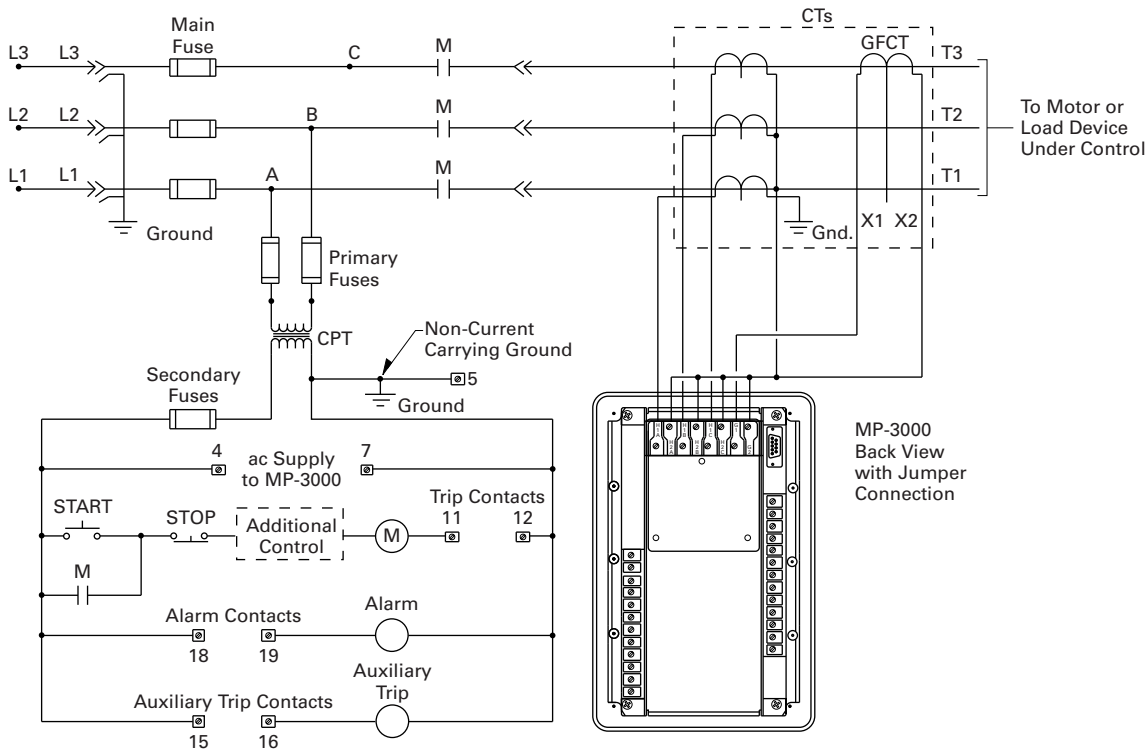

MP-3000 Terminal Identification

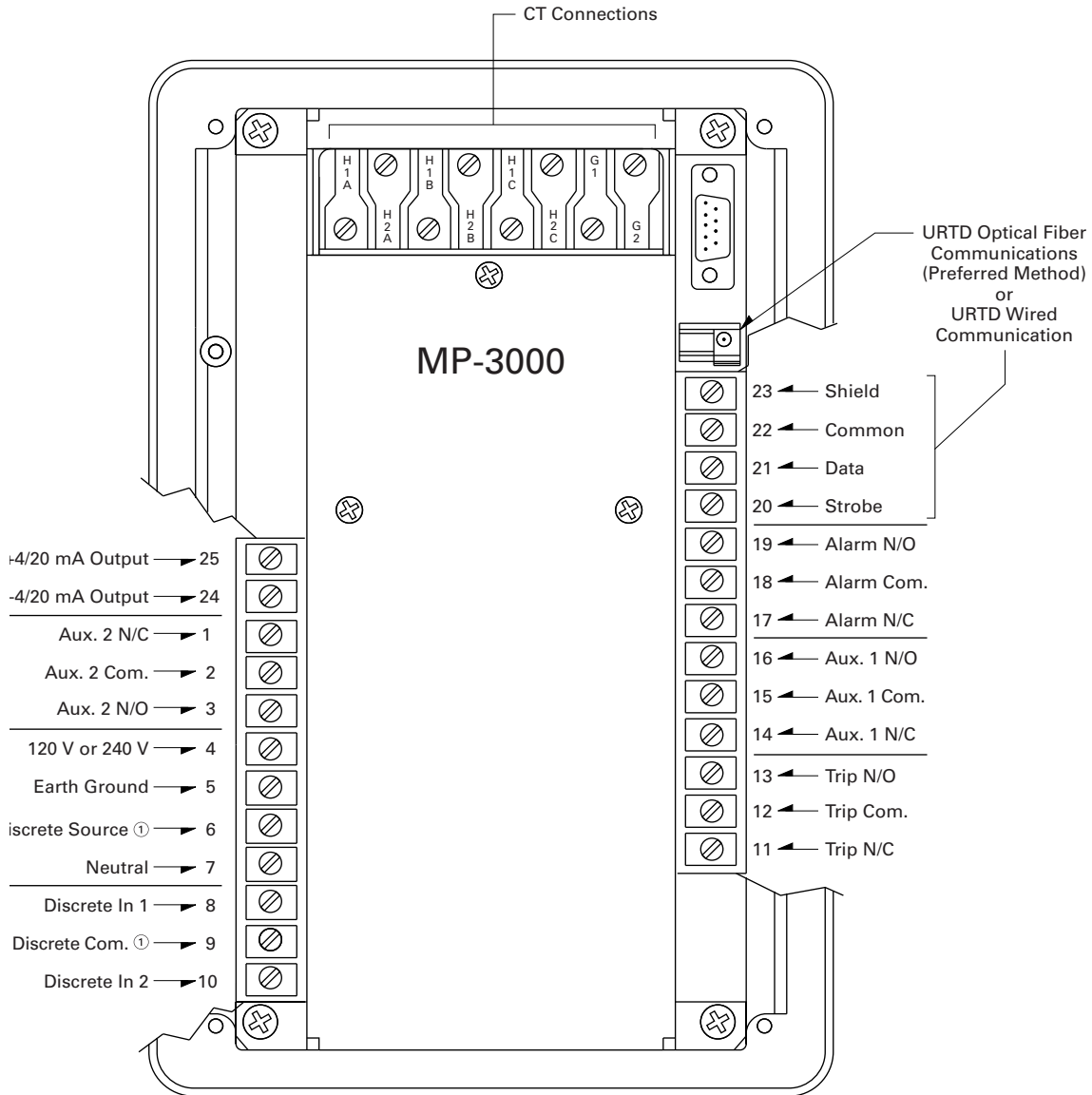

Note

① **Caution:** Do not connect terminals 6 and 9 together.

MP-3000 Control and URTD Wiring

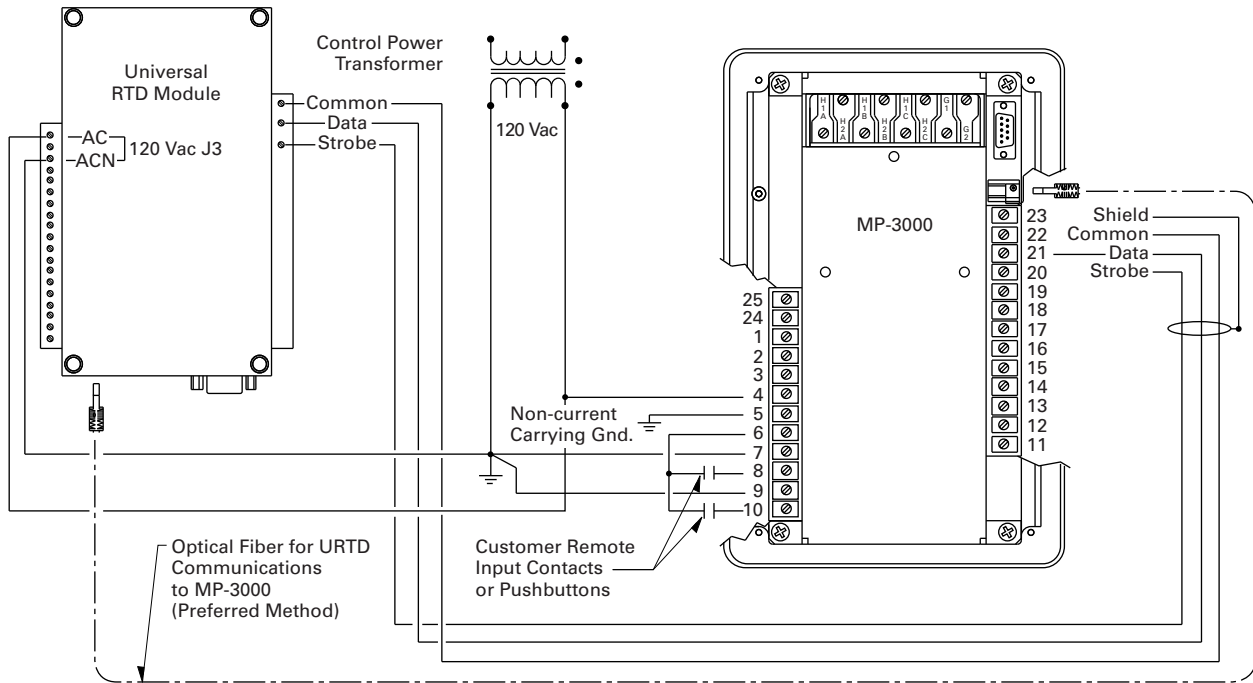

Trip Curve Chart

The MP-3000 motor relay records information on the most recent four starts. It records currents, percent of I²t used, percent unbalance, RTD temperatures and time to transition and run. In addition, a motor start profile can be downloaded and displayed using Eaton's PowerPort or PowerNet Software. The starting profile shows the motor starting current plotted against the relay protection curve. This provides a quick view of the coordination between the protection and actual motor start current.

When communications are desired, an optional communication module or PONI (Product Operated Network Interface) is required. The MP-3000 is compatible with an INCOM (IPONI), Modbus RTU (MPONI) or Ethernet (EPONI). Future communication modules are planned to interface with other systems using other protocols. Please consult factory for availability of other communication options. **Page V3-T9-172** shows typical mounting of MP-3000 with optional PONI and with URTD module and PONI.

When the MP-3000 is supplied in the optional drawout case, then the INCOM (IPONI) is the only communication option available. The communication option must be selected at the time of order.

Motor Starting Profile Time/Current Chart

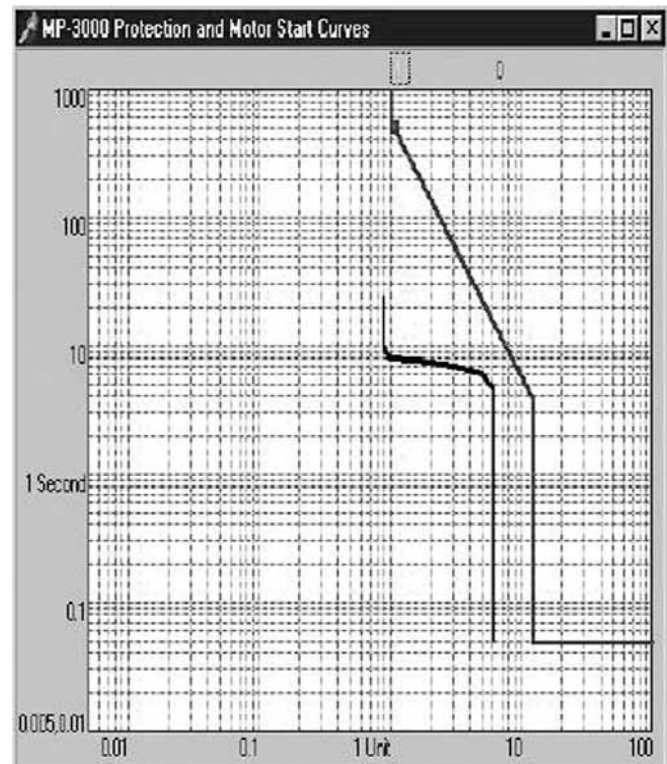

Dimensions

Approximate Dimensions in Inches (mm)

Panel Cutout Diagram

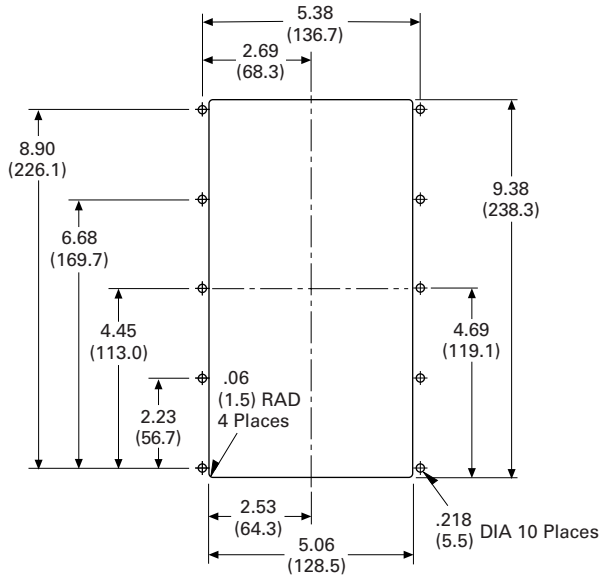

MP-3000 Drawout Panel Mounting

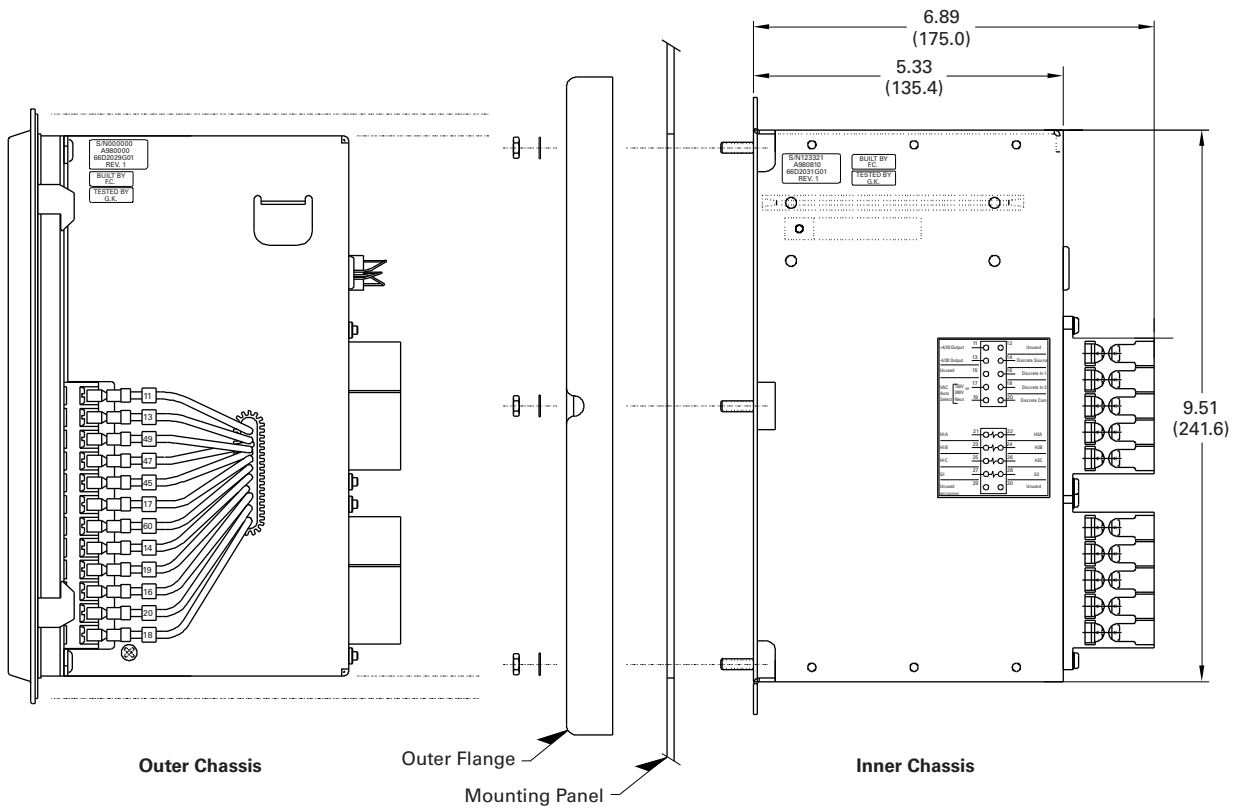

Approximate Dimensions in Inches (mm)

Rear View of MP-3000 Drawout Outer Case

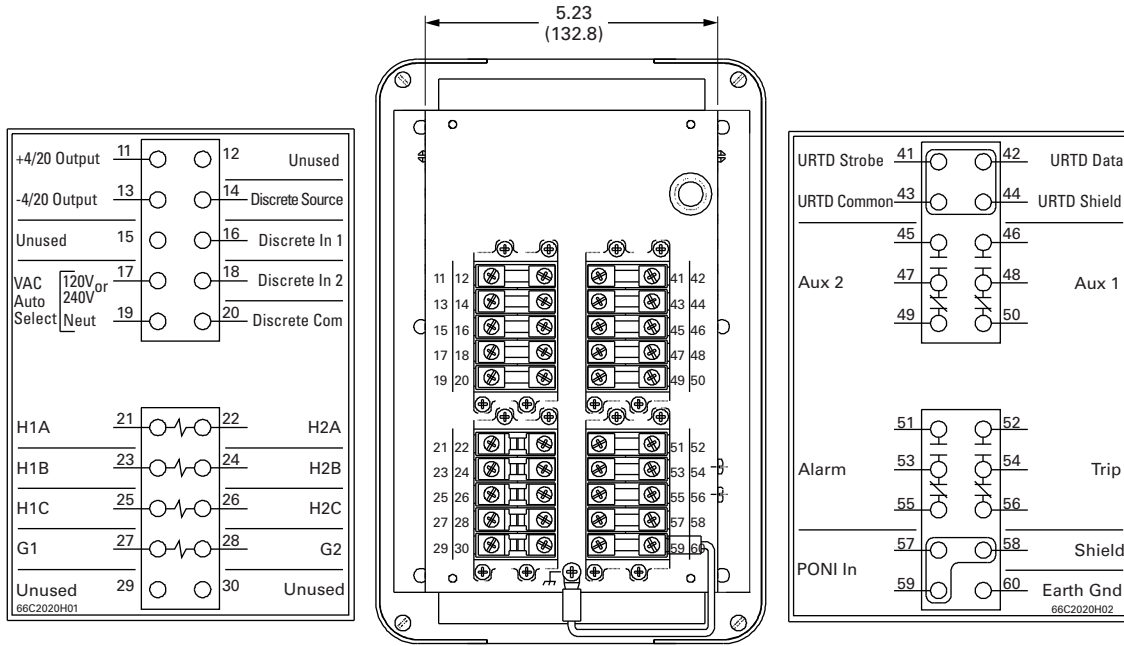

9.3

Metering Devices, Protective Relays, Software and Connectivity

Protective Relays

Approximate Dimensions in Inches (mm)

MP-3000 PONI and URTD Mounting

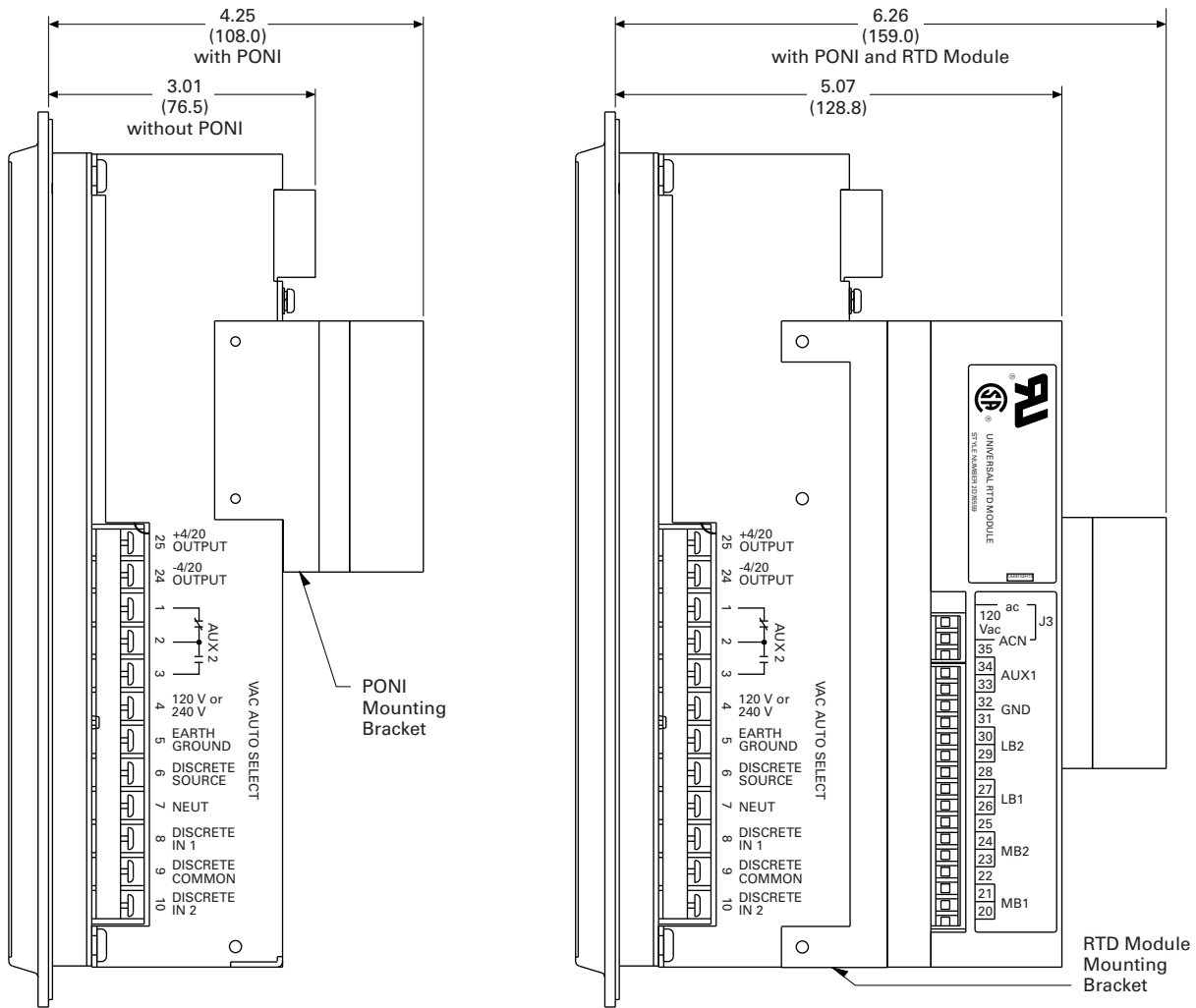

FP-3000 Feeder Protection Relay

Height	Width	Depth	Shipping Weight Lbs (kg)
10.25 (260.4)	6.72 (170.7)	3.70 (94.0)	7.0 (3.2)

MP-4000



Contents

<i>Description</i>	<i>Page</i>
Product Selection Guide	V3-T9-117
Digitrip 3000	V3-T9-123
EDR-3000 Feeder Protection.	V3-T9-133
EDR-5000 Distribution Protection Relay	V3-T9-142
FP-5000 Feeder Protection	V3-T9-155
MP-3000 Motor Protection	V3-T9-163
MP-4000 Motor Protection	
EMR-3000 Motor Protection Relay	V3-T9-179
EMR-4000 Motor Protection Relay	V3-T9-191
EMR-5000 Motor Protection Relay	V3-T9-204
ETR-4000 Transformer Protection Relay	V3-T9-216
ETR-5000 Transformer Protection Relay	V3-T9-228
EGR-5000 Generation Protection Relay	V3-T9-241
Ground Fault Relay	V3-T9-254
Universal RTD Module	V3-T9-257

MP-4000 Motor Protection

Product Description

- Microprocessor-based, multi-function motor protection
- Intel-I-Trip overload protection based on motor data
- Event recording and operational logging
- Motor Start Profile
- Optional Quick Release Drawout Case
- Used on AMPGARD and medium voltage assemblies
- “Help” menu provides user operational assistance

Application Description

Eaton’s MP-4000 motor protection relay is a multifunctional microprocessor-based protective relay for the protection of three-phase ac motors. The MP-4000 motor relay may be applied to any size motor at any voltage level. It is most commonly used on large, medium voltage three-phase induction motors. It has also been widely used on important low voltage (480 volt) motor applications and synchronous motors.

The MP-4000 motor relay monitors three-phase and ground currents, and three-phase voltages. It provides motor overload, stall, short circuit, phase unbalance, single phasing over/undervoltage, underpower, power factor and ground fault motor protection.

It can also be used to provide protection for a load jam or loss of load condition.

The MP-4000 motor relay provides start control logic to protect the motor against excessive starts or starting the motor before it has had

sufficient time to cool down. The MP-4000 motor relay may be applied to either across the line starters or reduced voltage starters. On reduced voltage starters, the MP-4000 relay can control the switch from reduced voltage to full voltage based on time and/or motor transition. The MP-4000 can protect the starter against failure to transition to full voltage through contact feedback and an incomplete sequence function.

The MP-4000 motor relay is generally used on a motor starter or a breaker used for a motor load. The MP-4000 motor relay provides the intelligence to protect and control the motor against abnormal operating conditions. It monitors the currents from either a 5 A or 1 A secondary of a CT circuit. Ground current may be obtained from either a ground CT or from the residual connection of the phase CTs. It provides a form C contact output for controlling the starter contacts or breaker operation.

Features, Benefits and Functions

- Complete motor protection and control in a single compact case reduces panel space requirements and wiring costs
- Microprocessor design with self diagnostics eliminates calibration and reduces installation, commissioning and maintenance
- Programmable stop 2–20% of PCT
- Intel-I-Trip overload protection develops customized curve from manufacturer's supplied motor data
- Intel-I-Trip overload protection provides adaptive trip characteristics based on motor temperature when motor RTDs are connected through an optional URTD module
- Meets UL 1053 ground fault protection standards that eliminates the need for a separate ground relay saving cost, space, wiring and time
- Voltage dip/loss ride through capability reduces unnecessary trips caused by poor power quality
- Motor currents, temperatures and conditions are monitored and displayed either locally or remotely
- Event log provides motor operating records for the most recent 20 Trip or Alarm events with date and time stamping. This information can improve troubleshooting and reduce downtime
- Log book records the most recent 100 events such as motor START/STOP and set point changes to provide a log of motor operation with date and time stamping
- RTD diagnostics reduces unnecessary tripping caused by faulty RTD, RTD wiring or communications
- Arm/Disarm feature improves security for critical motor applications
- Motor Start profile verifies protection and motor starting coordination. This feature can be used to develop protection settings on old motors where data is not available
- Optional communication module and Eaton's software simplifies setting, configuration, monitoring, commissioning and data retrieval either locally or remotely
- Optional Quick Release Drawout Case construction simplifies relay removal and replacement

The protection functions are listed below:

- I^2t overload protection (49/51)
- Locked rotor (49S/51)
- Ultimate trip current (51)
- Negative sequence phase unbalance (46)
- Instantaneous overcurrent (50)
- Ground fault protection (50G)
- Undervoltage (27)
- Overvoltage (59)
- Under power (32)
- Negative sequence voltage unbalance (47)
- Power factor (55)
- RTD trip and alarm with URTD module (49/38)
- Underload trip (37)
- Starts per time (66)
- Jam or stall (51R)
- Auto or manual reset (86)
- Fail-safe or non-fail-safe trip modes

The metering functions are:

- Metering:
 - Average current
 - Amperes: magnitude and angle in primary values
 - Amperes: positive, negative and zero sequence
 - Average voltage (V ave)
 - Voltage: magnitude and angle
 - Voltage: positive, negative and zero sequence
 - % of full load
 - % current unbalance
 - % voltage unbalance
 - Power, vars and VA
 - Power factor
 - Frequency
 - Energy metering with time and date stamps
- RTD temperatures:
 - Individual winding
 - Motor bearing
 - Load
 - Auxiliary temperatures
- Motor conditions:
 - Percent of I^2t thermal bucket
 - Time before start
 - Remaining starts allowed
 - Oldest start time

Standards and Certifications

The MP-4000 motor protection was designed to meet the industry standards for protective relays. It is recognized under UL 1053 Ground Fault Protection Standard.

- UL recognized (File No. E154862)
- UL 1053 recognized
- UL 508 recognized
- ANSI C37.90, C37.90.1
- cUL
- CSA



Reference Information

Cross-Reference

Westinghouse®/Cutler-Hammer

Eaton’s Cutler-Hammer MP-3000 motor relay supersedes the Cutler-Hammer (formerly Westinghouse) IQ 1000 II motor relay and can replace the earlier IQ 1000 motor relay version sold under the Westinghouse name. The MP-3000 motor relay fits in the same cut out and provides the protection functions of these older models. The MP-3000 relay provides numerous enhancements and new features over the superseded

models. The most notable enhancements are UL 1053 ground fault protection certified, voltage loss ride through capability, data logging, communications features and the addition of a clock for date and time stamping of events.

GE Multilin™

GE Multilin has several product offerings for motor protection. The 269 PLUS is the equivalent model to the MP-3000 with optional URTD module. Eaton offers MP-

3000 value packs that include an MP-3000, PONI, URTD module and fiber optic cable at competitive prices.

GE Multilin has both lower and higher end products. The MP-3000 can be used in place of their 239 motor relay. The MP-3000 offers more capabilities than the 239 for a slightly higher price.

GE Multilin 369 and 469 are upgraded end products. The MP-3000 relay offers equivalent overload and current protection functions.

It also provides equivalent start control functions. Both the 369 and 469 offer voltage protection and metering functions. An Eaton meter and/or other manufacturers’ protective relays may be needed to satisfy the customer’s motor protection requirements. The 469 adds differential protection. This function must be supplied by others in addition to the MP-3000 motor relay.

Cross-Reference

New Eaton’s Series	Old Cutler-Hammer (Westinghouse)	GE Multilin
MP-3000 (URTD module) ①	IQ 1000 II, IQ 1000	269, 269+, 239, base 369
MP-4000 (URTD module) ①	—	369 with voltage option
MP-4000 + MP-3000	—	469

Note

① If RTD monitoring required.

Product Selection

MP-4000



MP-4000 Ordering Information

Description	Catalog Number
MP-4000 drawout, 5 A with RS-232	MP4011
MP-4000 drawout, INCOM, 5 A with RS-232	MP4012
MP-4000 drawout, Modbus, 5 A with RS-232	MP4013
MP-4000 drawout, DeviceNet, 5 A with RS-232	MP4014
MP-4000 drawout, 1 A with RS-232	MP4111
MP-4000 drawout, INCOM, 1 A with RS-232	MP4112
MP-4000 drawout, Modbus, 1 A with RS-232	MP4113
MP-4000 drawout, DeviceNet, 1 A with RS-232	MP4114
MP-4000 fixed case, 5 A with RS-232	MP4010
MP-4000 fixed case, INCOM, 5 A with RS-232	MP4010INCOM
MP-4000 fixed case, Modbus, 5 A with RS-232	MP4010MODBUS
MP-4000 fixed case, DeviceNet, 5 A with RS-232	MP4010DEVICEN
MP-4000 fixed case, 1 A with RS-232	MP4110
MP-4000 fixed case, INCOM, 1 A with RS-232	MP4110INCOM
MP-4000 fixed case, Modbus, 1 A with RS-232	MP4110MODBUS
MP-4000 fixed case, DeviceNet, 1 A with RS-232	MP4110DEVICEN
MP-4000 fixed case, INCOM, 5 A with RS-232, URTD	MP4010VPI
MP-4000 fixed case, Modbus, 5 A with RS-232, URTD	MP4010VPM
MP-4000 fixed case, DeviceNet, 5 A with RS-232, URTD	MP4010VPD
MP-4000 fixed case, INCOM, 1 A with RS-232, URTD	MP4110VPI
MP-4000 fixed case, Modbus, 1 A with RS-232, URTD	MP4110VPM
MP-4000 fixed case, DeviceNet, 1 A with RS-232, URTD	MP4110VPD

Options and Accessories

Additional Related Products by Eaton's Cutler-Hammer Series

The MP-4000 is available in either a fixed mount or Quick Release Drawout Case. Both mountings use the same panel cutout.

The Universal RTD module (URTD) is required when the motor is equipped with RTDs that you wish to monitor and use for protection. The URTD can be mounted near the motor to reduce RTD wiring and costs.

The MP-4000 motor protection is design-ed to operate from 120 Vac or 240 Vac auxiliary control power. The MP-4000 motor relay can be used with dc control power with the addition of the IQDCPS. The IQDCPS is an inverter from DC to AC.

Technical Data and Specifications

Control Power

- Nominal rating:
 - 120 Vac or 240 Vac
 - +10%, -25%
- Operating range:
 - 120 Vac: 90 132 Vac
 - 240 Vac: 180 264 Vac
- Frequency: 50 or 60 Hz
- Power use:
 - 20 VA maximum
 - URTD: 6 VA maximum
 - IPONI: 1 VA maximum
- Ride-through time: 30 cycles from nominal Vac

Current Inputs

- Nominal (I_n): 1 A or 5 A
- CT rating:
 - 2 x I_n continuous
 - 50 x I_n for 1 second
- Burdens:
 - < 0.25 VA at 5 A
 - < 0.05 VA at 1 A

Voltage Inputs

- Nominal: 120 Vac
- Operating range: 69 to 150 Vac
- Burden: 2 VA

Metering Accuracy

- Phase current: $\pm 1\%$ of I_n (5–100%)
- Ground current: $\pm 1.5\%$ of I_n (0–55%)

Discrete Inputs

- Number of inputs: two programmable
- Ratings:
 - 1.2 VA at 120 Vac
 - Maximum off = 36 Vac
 - Minimum on = 86 Vac

Output Contacts

- Number of outputs: four Form C, programmable.
- Momentary:
 - Make 30 A AC/DC for 0.25 seconds
 - Break 0.25 A at 250 Vdc (Resistive)
 - Break 5 A at 120 240 Vac
- Continuous:
 - 5 A at 120/240 Vac
 - 5 A at 30 Vdc

Analog Output

- Rating: ± 4 –20 mA programmable
- Maximum load: 1K ohm
- Accuracy: 1%

Motor Overload Protection (I^2t)

- Full load amperes: 10–3000
- Locked rotor current: 300–1200% FLA
- Locked rotor time: 1–120 seconds
- Ultimate trip current: 85–150% FLA
- Phase CT ratio: 10–4000 (I_n)
- Ground CT ratio: 10–4000 (I_n)
- Timing accuracy: $\pm 2.5\%$ or ± 30 ms for $I > 1.1 \times$ U.T.C.

Trip Setting Range

- Ground fault (GF): Off, 2–55% CT ratio
- GF start time delay: 2–60 cycles
- GF run time delay: 0–60 cycles
- Timer accuracy: ± 20 ms
- Instantaneous O.C.: Off, 300–1600% FLA
- IOC start time delay: 2–60 cycles
- Timer accuracy: ± 20 ms
- JAM trip: Off, 100–1200% FLA
- Underload trip: Off, 1–90% FLA
- Current unbalance trip: Off, 4–40% I_{neg}/I_{pos}
- Start delay timers:
 - 0–120 seconds (underload and phase unbalance)
 - 0–1200 seconds (jam)
- Run delay timers: 0–240 seconds
- Timer accuracy: $\pm 0.5\%$ +100 ms
- Voltage unbalance: Off, 1 to 100 V
- % $V2/V1$: 4% + 40%
- Voltage unbalance time delay: 0 to 1200 s
- Under/overvoltage time delay: Off, 10 to 150 V
- Under/overvoltage time delay: 0 to 1200 s

- Under/overfrequency: Off, 15 to 60 Hz
- Under/overfrequency time delay: 0 to 60 sec
- Power protection: Off, 0.06 to .90 + FLA VT
- Power time delay: 0 to 1200 sec
- Power factor: Off, 0.05 lag to 0.99 lead
- Power factor time delay: 0 to 60 s

Alarm Setting Range

- Ground fault: Off, 2–55% CT ratio
- Overload I^2t : Off, 60–99% I^2t
- JAM: Off, 100–1200% FLA
- Underload: Off, 1–90% FLA
- Phase unbalance: Off, 4–40% I_{neg}/I_{pos}
- Run delay timers: 0–240 seconds

Start Control Functions

- Starts per time: 1–10 starts
- Time for starts per time: Off, 1–240 minutes
- Time between starts: Off, 1–240 minutes
- Number of cold starts: 1–5 starts
- Motor transition current: 10–300% FLA
- Time for transition: 0–1200 seconds
- Inc. sequence timer: Off, 1–240 seconds
- Long acceleration timer: Off, 1–1200 seconds
- Anti-Backspin timer: Off, 1–3600 minutes

RTD Inputs (Requires URTD module)

- Sensor types:
 - 10 ohm copper
 - 100 ohm nickel
 - 120 ohm nickel
 - 100 ohm platinum

URTD Module Communications

- Interface:
 - Electrical (three-wire)
 - Fiber optic (preferred)
- Fiber optic cable: Type HBFER-ERS or EUS

Clock

- Accuracy: ± 1 minute/month at 77 °F (25 °C)

PONI Communications

- Type: two-wire, FSK
- Baud rate: 1200 or 9600 baud
- Protocol: INCOM
- Functions:
 - Read/write set points
 - Read metered values
 - Read trip/alarms
 - Read events/history
 - View starting profile

MPONI Communications

- Type: five-wire, 485
- Baud rate: 1200 or 9600 baud
- Protocol: Modbus RTU
- Functions:
 - Read metered values
 - Read trip/alarms

DPONI Communications

- Type: J-wire
- Baud rate: 500 k, 250 k, 125 k
- Protocol: DeviceNet
- Functions:
 - Read metered values
 - Read trip/alarms

Logging

- Log book: 100 events
- Log event: 20 trips and alarms
- Log start: last four starts
- Start profile: last four starts (communication only)
- History records: motor, trips, alarms and total records

Environmental Conditions

- Operating temperature: -4 °F to +140 °F (-20 °C to +60 °C)
- Storage temperature: -49 °F to +185 °F (-45 °C to +85 °C)
- Humidity: 0–95% noncondensing

9.3

Metering Devices, Protective Relays, Software and Connectivity

Protective Relays

Dimensions

Approximate Dimensions in Inches (mm)

MP-4000 Feeder Protection Relay

Height	Width	Depth	Shipping Weight Lbs (kg)
10.25 (260.4)	6.72 (170.7)	3.70 (94.0)	7.0 (3.2)

EMR-3000 Motor Protection Relay



Contents

<i>Description</i>	<i>Page</i>
Product Selection Guide	V3-T9-117
Digitrip 3000	V3-T9-123
EDR-3000 Feeder Protection.	V3-T9-133
EDR-5000 Distribution Protection Relay	V3-T9-142
FP-5000 Feeder Protection	V3-T9-155
MP-3000 Motor Protection	V3-T9-163
MP-4000 Motor Protection	V3-T9-173
EMR-3000 Motor Protection Relay	
EMR-4000 Motor Protection Relay	V3-T9-191
EMR-5000 Motor Protection Relay	V3-T9-204
ETR-4000 Transformer Protection Relay	V3-T9-216
ETR-5000 Transformer Protection Relay	V3-T9-228
EGR-5000 Generation Protection Relay	V3-T9-241
Ground Fault Relay	V3-T9-254
Universal RTD Module	V3-T9-257

EMR-3000 Motor Protection Relay

Product Description

Eaton’s EMR-3000 motor protection relay is a multifunctional microprocessor- based protective relay for the protection of any size motor at all voltage levels. It is most commonly applied on medium voltage or larger motors. The EMR-3000 relay is a current only device that provides complete and reliable motor protection, monitoring, and starting control functions.

The EMR-3000 motor protection relay has removable terminal blocks, and it has Modbus-RTU communications as standard; and an optional Ethernet port for Modbus-TCP communications. The EMR-3000 motor protection relay has three-phase and one ground current inputs. It can be used with either a 5 A or 1 A CTs. The ground protection can be used with either a zero sequence ground CT or from the residual connection of the phase CTs.

The zero sequence ground CT provides greater ground fault sensitivity than the residual connection. The unit is capable of 60 Hz or 50 Hz operation.

The maintenance mode password protected soft key, can be used for arc flash mitigation to change to an alternate settings group, set to have instantaneous elements only. The multiple setting groups can also be changed, via communications or a digital input. Flash memory is used for the programming and all settings are stored in nonvolatile memory.

An integral keypad and display is provided for direct user programming and retrieval of data without the need of a computer. 14 programmable LEDs provide quick indication of relay status.

A front port is provided for direct computer connection. An RS-485 communication port on the back is standard for local area networking

using Modbus-RTU. An optional Ethernet port and protocols are available.

The EMR-3000 motor protection relay has mass memory for data storage and a real-time clock with 1 ms time resolution. The relay will log 300 sequence of event records, 20 detailed trip logs, minimum/maximum values, load profiles, the 5 latest start profiles, motor trending, breaker wear information and oscillography data.

The EMR-3000 motor protection relay has four discrete inputs and 1 fiber optic input, 1 Form C, and 2 NO programmable contacts, 1 Form C healthy contact. It also has an optional 4–20 mA analog output or zone interlocking card. The relay provides maximum user flexibility to configure the I/O. All inputs and outputs (except the healthy output) are user-programmable. The unit also counts with a test mode to force outputs and simulate currents, to facilitate the commissioning of the unit.

It can be powered from 19 Vdc to 300 Vdc or 40 Vac to 250 Vac auxiliary power.

Application Description

Eaton’s EMR-3000 motor protection relay has been designed for maximum motor operation and protection. It permits running the motor close to its design limits while protecting it against excessive heating and damaging overload conditions. The EMR-3000 field-proven protection algorithms were developed based on motor designs and operating parameters for optimum operation and protection while minimizing nuisance tripping. The EMR-3000 motor protection relay utilizes a patented protection algorithm and measurement technique based on proven positive and negative (unbalance) sequence current sampling and true RMS calculations.

Features, Benefits and Functions**Protection Features**

- Thermal protection (49/51)
 - Locked rotor protection (49S/51)
- Phase overcurrent elements:
 - Two instantaneous elements with timers (50P[1], 50P[2] and 50P[3])
 - Three inverse time overcurrent elements (51P[1], 51P[2] and 51P[3])
 - 11 standard curves
 - Instantaneous or time delay reset
- Ground overcurrent elements:
 - Two instantaneous measured elements with timers (50X[1] and 50X[2])
 - Two instantaneous calculated elements with timers (50R[1] and 50R[2])
 - Two inverse time overcurrent measured elements (51X[1] and 51X[2])
 - Two inverse time overcurrent calculated elements (51R[1] and 51R[2])
 - 11 standard curves
 - Instantaneous or time delay reset
- Jam or Stall protection (50J[1], 50J[2])
- Phase unbalance negative sequence overcurrent (46[1], 46[2])
- Underload protection (37[1], 37[2], 37[3])
- Temperature protection with optional URTD (49/38)
- Stars per hour (66)
- Lockout protection (86)
- Breaker failure (50BF)
- Zone interlocking for bus protection (87B)

Metering Features

- Amperes: Positive, negative and zero sequence
- Ampere demand
- % THD I
- Magnitude THD I
- Minimum/maximum recording
- Temperature with remote URTD module

Monitoring Features

- Trip coil monitor
- Breaker wear primary and secondary (accumulated interrupted current)
- Oscillography (7200 cycles total)
- Trip Cause displays fault recorder data on HMI after fault event
- Fault data logs (up to 20 events)
- Sequence of events report (up to 300 events)
- Trending (load profile over time)
- Motor history
- Records the last 5 motor start profiles
- Motor start trending
- CT supervision
- Clock (1 ms time stamping)

Control Functions

- Transition for reduced voltage starts
- Incomplete sequence delay
- Permits numbers of cold starts
- Limits numbers of starts per hour
- Anti-backspin time delay
- Mechanical load shedding
- Zero speed switch for long acceleration motors
- Motor stop inputs
- Remote trip input
- Differential trip input
- Emergency override
- Breaker/Contactor open-close/stop-start
- Remote open-close (stop-start)
- Programmable I/O
- Programmable LEDs
- Multiple setting groups

Communication Features

- Local HMI
- Password protected
- Addressable
- IRIG-B
- Local communication port:
 - RS-232
- Remote communication port:
 - RS-485
 - Ethernet port
- Protocols:
 - Modbus-RTU
 - Modbus-TCP (optional)
 - IEC 61850 (optional)
- Configuration software
 - PowerPort-E

Trip Log

The EMR-3000 protection relay will store a maximum of 20 trip records in a FIFO trip log. Each trip record will be date and time stamped to a 1 ms resolution. The trip log record will include information on the type of fault, protection elements that operated, fault location and currents and voltages at the time of the fault.

Monitoring and Metering**Sequence of Events Records**

The EMR-3000 protection relay records a maximum of 300 events associated with the relay. An event is classified as a change of state as detected by the relay. These include relay pickups, dropouts, trips, contact closure, alarms, setting changes and self-diagnostic failures. Each event is date and time stamped to a 1 ms resolution. The events are stored in a FIFO in chronological order.

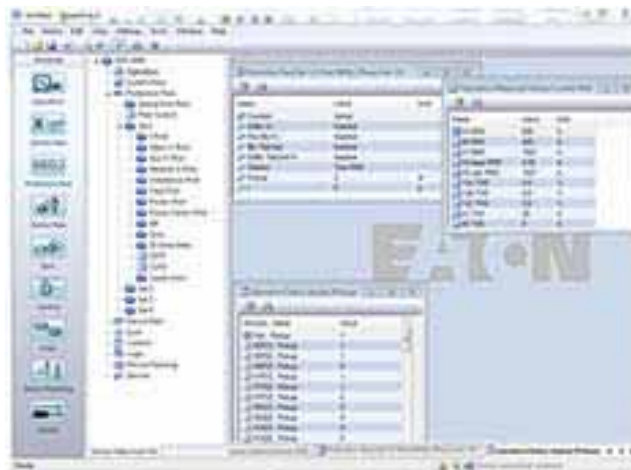

Waveform Capture (Quality Manager)

The EMR-3000 relay provides oscillographic recording capabilities. The relay will record all measured signals along with the binary signals of pickup, trip, internal logic, and contact inputs. The EMR-3000 can record up to 7200 cycles of data. The number of records is proportional to the programmed size of each record; the maximum size per record is 600 cycles.

The waveform capture is initiated by up to 8 different triggers (i.e., trip/alarm events) or manually via communications or the HMI. PowerPort-E setting software is used to retrieve the records. Quality Manager is a separate software program downloaded with PowerPort-E used for analyzing the waveform and trending files retrieved from the relay.

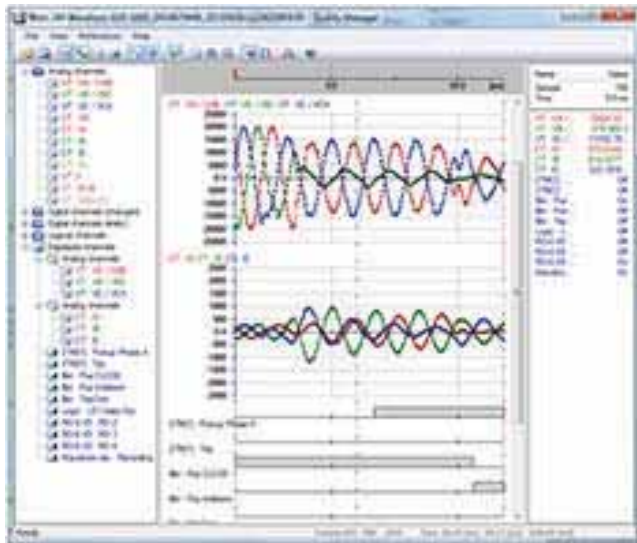

Integral User Interface

The front panel user interface has a 128 x 64 pixel LCD display with background illumination for wide angle viewing in all light conditions. Seven programmable LEDs provide quick and easy visual display of power on, mode of operation, alarm and trip indication. Soft keys are provided for operation mode selection, scrolling through data and settings. In addition, the relay settings and test functions are password protected.

Starting Profiles

The EMR-3000 records the average current versus time for the last five starting cycles. This information is available via the communications port through PowerPort-E.

Motor Statistics

For each motor start, the EMR-300 stores a motor start report and add this data to the motor statistics buffer. With the motor statistics you can track motor start data for the past eighteen 30-day periods. For each 30-day interval, the relay records the following information:

- The date the interval began
- The total number of starts in the interval
- The averages of the following quantities:
 - Motor Start Time
 - Start % Rotor Thermal Capacity Used
 - Maximum Start Current

Load Profiling/Trending

The EMR-3000 relay automatically records selected quantities into non-volatile memory every 5, 10, 15, 30 or 60 minutes, depending on the trending report setting.

Programmable I/O

The EMR-3000 motor protection relay provides heavy-duty, triparted, 2 normally open and 1 Form C contacts. One isolated inputs can be used for monitoring the trip circuit. One Form C contact is dedicated to the relay failure alarm function and is operated in a normally energized (failsafe) mode. There are 4 eight user-configurable discrete inputs that accept a wet contact and can operate through a wide range of power. Each input and output is user-programmable for maximum application flexibility.

Intel-I-Trip (I²t) Overload Protection

The EMR-3000 motor relay features the exclusive Eaton Intel-I-Trip intelligent overload protection system. Intel-I-Trip develops custom overload curves simply from motor nameplate data. Intel-I-Trip protects motors from potentially damaging overload and abnormal operating conditions. The Intel-I-Trip intelligent overload protection feature utilizes field proven measurement techniques and a patented motor thermal protection model. The EMR-3000 motor relay's unique measurement technique samples the current waveforms 36 times per cycle, providing accurate measurements of the positive and negative sequence currents. The negative sequence current causes a greater heating effect on the rotor and has a greater impact on the thermal model in the relay. Intel-I-Trip utilizes these measurements in its motor model to safely protect the motor against the heating effects of these currents.

The motor thermal model is analogous to a bucket that is being filled and drained at the same time. The fill rate is dependent on the motor currents and the drain is based on motor design principles. The size of the bucket is equivalent to the thermal capacity associated with the mass of the motor. Intel-I-Trip integrates these rates and will issue a trip when the thermal capacity is filled.

Intel-I-Trip features adaptive trip characteristics that adjust the trip times based on measured motor temperature when RTDs are used.

Instantaneous Overcurrent

The EMR-3000 motor protection relay provides an instantaneous phase overcurrent function to trip the motor for high fault current levels and save the fuses. This function can be disabled and has an adjustable time delay on starting to avoid nuisance tripping on inrush.

Phase Unbalance Protection

Motor supply circuits are often fed through fuses and can be run with a single-phase fuse blown, referred to as single phasing the motor. The EMR-3000 motor protection relay measures the current unbalance and can be used to alarm or trip the motor before damage occurs. Pickup, start and run timers, and a second element for alarm purposes are provided.

Ground Fault Protection

A separate measuring circuit is used to measure ground current. A ground CT is recommended for more sensitive protection against winding insulation breakdown to ground. The relay ground circuit can be connected residually from the three-phase CTs. The ground fault protection has pickup and time delay set points or can be disabled.

Jam Protection

The user-selectable Jam function protects motors that are running against a sudden mechanical jam or stall condition. The common application is on motors used on crushers, chippers, or conveyors. It detects an increase of motor current to a level above full load. Pickup, start, and run timers and a second element for alarm purposes are provided.

Underload Protection

The user-selectable underload function is used to detect the loss of load on the motor. Coupling failure is a common cause for loss of load. Pickup, start, and run timers and a second element for alarm purposes are provided.

Reduced Voltage Starting

The EMR-3000 motor protection relay provides a transition and incomplete sequence function for reduced voltage starting. The user can select to transition based on the current level and/or on time.

Antibackspin

The stop function is programmable from 2–20%. For certain applications, such as pumping a fluid up a pipe, the motor may be driven backward for a period of time after it stops. The EMR-3000 relay provides an antibackspin timer to prevent starting the motor while it is spinning in the reverse direction. The timer begins counting from the moment a stop is declared by the relay.

Start Control Timers

Motors typically have limits to the number of cold starts, starts per hour period, or time between starts that are permitted without damage. The EMR-3000 motor protection relay incorporates these timers to prevent starting the motor beyond its capabilities.

Load Shedding

The EMR-3000 motor protection relay provides a mechanical load shedding feature that can be used to control an upstream process. The load-shedding function closes a contact on an overload condition to control an upstream process from adding more load until the overload condition is gone.

Emergency Override

The EMR-3000 motor protection relay has a user-programmable feature that will let the operator reset the start inhibitor timers and thermal overload bucket. This function is intended for use in emergency conditions only, and it may result in motor damage or failure.

Long Acceleration Motors

Large motors with a high inertia may experience starting currents that exceed the locked rotor current and time. The EMR-3000 motor protection relay has logic and provisions for a zero speed switch input to differentiate between a stall and start condition. If the motor is spinning, then the relay will not trip on the normal locked rotortime allowing the motor to start.

Remote/Differential Trip

The digital inputs can be programmed to accept a contact input from a separate differential relay or other device to trip the motor. This provides local and remote target information and utilizes the trip contacts of the EMR-3000 motor protection relay. It will also record and log the motor information at the time of the trip.

Breaker Failure or Stuck Contactor

The EMR-3000 motor protection relay includes a breaker failure (50BF, 62BF) function that can be initiated from either an internal or external trip signal. This is an independent element that can be used to operate a lockout relay or trip an upstream breaker. The timer must be longer than the breaker operating time and the protective function reset times.

Flexible Phase Rotation

The EMR-3000 motor protection relay can be applied on either an A-B-C or A-C-B phase rotation. A user setting permits correct operation and indication of the actual system configuration.

Maintenance Mode

The Maintenance Mode can improve safety by providing a simple and reliable method to reduce fault clearing time and lower incident energy levels at energized panels. The Maintenance Mode allows the user to switch to more sensitive settings via a password protected soft key, communication or via a digital Input while maintenance work is being performed at an energized panel or device. The more sensitive settings provide greater security for maintenance personnel and helps reduce the possibility of injury.

Standards and Certifications

Design Standards

- Generic Standard:
 - EN 61000-6-2
 - EN 61000-6-3
- Product Standard:
 - IEC 60255-6
 - EN 50178
 - UL 508 (Industrial Control Equipment)
 - CSA C22.2 No. 14-95 (Industrial Control Equipment)
 - ANSI C37.90



Catalog Number Selection

The catalog number identification chart defines the electrical characteristics and operation features included in the EMR-3000. For example, if the catalog number is EMR-3000-2A0BA1, the device would have the following:

EMR-3000

(A)–Four digital inputs, four output relays, 1 4–20 mA analog output, URTD interface

(0)–5 A / 1 A phase and ground CTs, power supply range: 19–300 Vdc, 40–250 Vac

(B)–Modbus-RTU (RS-485)

(A)–Without conformal coating

(1)–Projection panel mount

Motor Relay Removable Terminals

EMR-3000-2A 0 B A 1

Hardware Option 1

A = 4 DI, 4 outputs, removable terminals, 1 4–20 mA analog output, URTD interface, IRIG-B small display

B = 4 DI, 4 outputs, removable terminals, zone interlocking, URTD interface, IRIG-B, small display

Hardware Option 2

0 = Phase current 5 A / 1 A, ground current 5 A / 1 A, power supply range: 19–300 Vdc, 40–250 Vac

1 = Phase current 5 A / 1 A, sensitive ground current 0.5 A / 0.1 A, power supply range: 19–300 Vdc, 40–250 Vac

Communication Options

B = Modbus/DNP3 RTU over RS-485

C = Modbus/DNP3 TCP over Ethernet RJ-45

D = PROFIBUS-DP over fiber optic ST

E = PROFIBUS-DP over D-Sub / RS-485

F = Modbus RTU or DNP3 RTU over fiber optic ST

G = Modbus/DNP3 RTU over D-Sub / RS-485

H = IEC 61850/Modbus/DNP3 TCP over Ethernet RJ-45

I = Modbus/DNP3 RTU over RS-485 or Modbus/DNP3 TCP over Ethernet RJ-45

K = IEC 61850/Modbus/DNP3 TCP over LC duplex fiber optic Ethernet

L = Modbus/DNP3 TCP over LC duplex fiber optic Ethernet

Conformal Coating Options

A = None

B = Conformal coated circuit boards

Mounting Options

0 = Standard mount

1 = Projection panel mount

Accessories

Standard Accessories EMR-3000

Description	Catalog Number
UNVL RTD Mod with Modbus-RTU 48–240 Vac/48–250 Vdc	URTDII-01 ①
UNVL RTD Mod with Modbus-RTU 24–48 Vdc	URTDII-02 ①
E-SERIES 3000 IQ adapter kit projection mounted ②	ER-IQRETROKIT

Notes

- ① See URTD section for fiber optic cables required to communicate to the EMR-3000.
 ② Retrofitting mounting plate MP-3000 relay, projection panel mount necessary.

Technical Data and Specifications

Climatic Environmental Conditions

- Storage Temperature: –25 °C up to +70 °C (–13 °F to +158 °F)
- Operating temperature: –20 °C up to +60 °C (–4 °F to +140 °F)
- Permissible humidity at Ann. Average: <75% rel. (on 56d up to 95% rel.)
- Permissible Installation Altitude: <2,000 m (6,561.67 ft) above sea level.
- If 4,000 m (13,123.35 ft) altitude applies, a changed classification of the operating and test voltages may be necessary.

Degree of Protection EN 60529

- HMI front panel with seal: IP54
- Rear side terminals: IP30

Routine Test

- Insulation test acc. to IEC 60255-5: All tests to be carried out against ground and other input and output circuits.
- Aux. voltage supply, digital inputs, current measuring inputs, signal relay outputs: 2.5 kV (eff.) / 50 Hz
- Voltage measuring inputs: 3.0 kV (eff.) / 50 Hz
- All wire-bound communication interfaces: 1.5 kV DC

Housing

- Housing B1: height / width 183 mm (7.205 in) / 141.5 mm (5.571 in)
- Housing depth (incl. terminals): 208 mm (8.189 in)
- Material, housing: aluminum extruded section
- Material, front panel: aluminum/foil front
- Mounting position: Horizontal ($\pm 45^\circ$ around the X-axis must be permitted)
- Weight EMR-3000 housing B1: Approx. 2.4 kg (5.291 lb)

Plug-in Connector with Integrated Short-Circuiter (Conventional Current Inputs)

- Nominal current: 1 A and 5 A
- Continuous loading capacity: $4 \times I_N$ / continuously
- Overcurrent withstand:
 - $30 \times I_N / 10$ s
 - $100 \times I_N / 1$ s
 - $250 \times I_N / 10$ ms (1 half-wave)
- Screws: M4, captive type acc. to VDEW
- Connection cross sections:
 - 1 x or 2 x 2.5 mm² (2 x AWG 14) with wire end ferrule
 - 1 x or 2 x 4.0 mm² (2 x AWG 12) with ring cable sleeve or cable sleeve
 - 1 x or 2 x 6 mm² (2 x AWG 10) with ring cable sleeve or cable sleeve

Voltage Supply

- Aux. voltage: 24–270 Vdc / 48–230 Vac (–20/+10%)
- Buffer time in case of supply failure: ≥ 50 ms at minimal aux. voltage communication is permitted to be interrupted
- Max. permissible making current:
 - 18 A peak value for <0.25 ms
 - 12 A peak value for <1 ms
- The voltage supply must be protected by a fuse of:
 - 2.5 A time-lag miniature fuse 5 x 20 mm (approx. 1/5 in x 0.8 in) according to IEC 60127
 - 3.5 A time-lag miniature fuse 6.3 x 32 mm (approx. 1/4 in x 1 1/4 in) according to UL 248-14

Power Consumption

- Power supply range:
 - 19–300 Vdc: 6 W idle mode / 8 W max. power
 - 40–250 Vac: 6 W idle mode / 8 W max. power (For frequencies of 40–70 Hz)

Real Time Clock

- Running reserve of the real time clock: 1 year min.

Display

- Display type: LCD with LED background illumination
- Resolution—graphics display: 128 x 64 pixel
- LED Type: two colored: red / green
- Number of LEDs, housing B1: 8

Digital Inputs

- Max. input voltage: 300 Vdc / 270 Vac
- Input current: <4 mA
- Reaction time: <20 ms
- Fallback time: <30 ms
- (Safe state of the digital inputs)
- Switching thresholds: Un = 24 Vdc, 48 Vdc, 60 Vdc, 110 Vac / Vdc, 230 Vac / Vdc
 - Un = 24 Vdc
 - Switching threshold 1 ON:
 - Switching threshold 1 OFF:
 - Min. 19.2 Vdc
 - Max. 9.6 Vdc
 - Un = 48 V / 60 Vdc
 - Switching threshold 2 ON:
 - Switching threshold 2 OFF:
 - Min. 42.6 Vdc
 - Max. 21.3 Vdc
 - Un = 110 / 120 Vac/Vdc
 - Switching threshold 3 ON:
 - Switching threshold 3 OFF:
 - Min. 88.0 Vdc / 88.0 Vac
 - Max. 44.0 Vdc / 44.0 Vac
 - Un = 230 / 240 Vac/Vdc
 - Switching threshold 4 ON:
 - Switching threshold 4 OFF:
 - Min. 184 Vdc / 184 Vac
 - Max. 92 Vdc / 92 Vac
- Terminals: screw-type terminal

Current and Ground Current Measurement

- Nominal currents: 1 A / 5 A
- Max. measuring range:
 - Up to 40 x In (phase currents)
 - Up to 25 x In (ground current standard)
 - Up to 2.5 x In (ground current sensitive)
- Continuous loading capacity: 4 x In / continuously
- Overcurrent proof:
 - 30 x In / 10 s
 - 100 x In / 1 s
 - 250 x In / 10 ms (1 half-wave)
- Power consumption: phase current inputs
 - At In = 1 A burden = 0.15 MVA
 - At In = 5 A burden = 0.15 MVA
- Ground current input
 - At In = 1 A burden = 0.35 MVA
 - At In = 5 A burden = 0.35 MVA
- Frequency range: 50 Hz / 60 Hz $\pm 10\%$
- Terminals: screw-type terminals with integrated short-circuiters (contacts)

Binary Output Relays

- Continuous current: 5 A AC/DC
- Switch-on current: 25 A AC/DC for 4 s
- Max. breaking current:
 - 5 A AC up to 125 V ac
 - 5 A DC up to 50 V (resistive)
 - 0.2 A DC at 300 V
- Max. Switching Voltage: 250 Vac/300 Vdc
- Switching capacity: 2000 VA
- Contact type: 1 changeover contact
- Terminals: screw-type terminals

Front Interface RS-232

- Baud rates: 115200 baud
- Handshake: RTS and CTS
- Connection: 9-pole D-Sub plug

RS-485

- Master/slave: slave
- Connection: 6 screw-clamping terminals RM 3.5 mm (138 MIL) (terminating resistors internal)

Tolerances of the Real Time Clock

- Resolution: 1 ms
- Tolerance: <1 minute / month (+20 °C)

Measuring Accuracy

- Max. measuring range: Up to 40 x In (phase currents)
- Up to 25 x In (ground current standard)
- Frequency range: 50 Hz / 60 Hz $\pm 10\%$
- Accuracy: Class 0.5
- Amplitude error if $I < 1$ In: $\pm 0.5\%$ of the rated value
- Amplitude error if $I > 1$ In: $\pm 0.5\%$ of the measured value
- Amplitude error if $I > 2$ In: $\pm 1.0\%$ of the measured value
- Resolution: 0.01 A
- Harmonics: Up to 20% 3rd harmonic $\pm 2\%$ Up to 20% 5th harmonic $\pm 2\%$
- Frequency influence: $< \pm 2\%$ / Hz in the range of ± 5 Hz of the parametrized nominal frequency
- Temperature influence: $< \pm 1\%$ within the range of 0 °C up to +60 °C

Wiring Diagrams

Typical AC Connections—1 A CTs and Ground Current Measured by Zero Sequence CT

Connection Example Clockwise Rotating Field
EMR-3000 => Terminal Marking X3

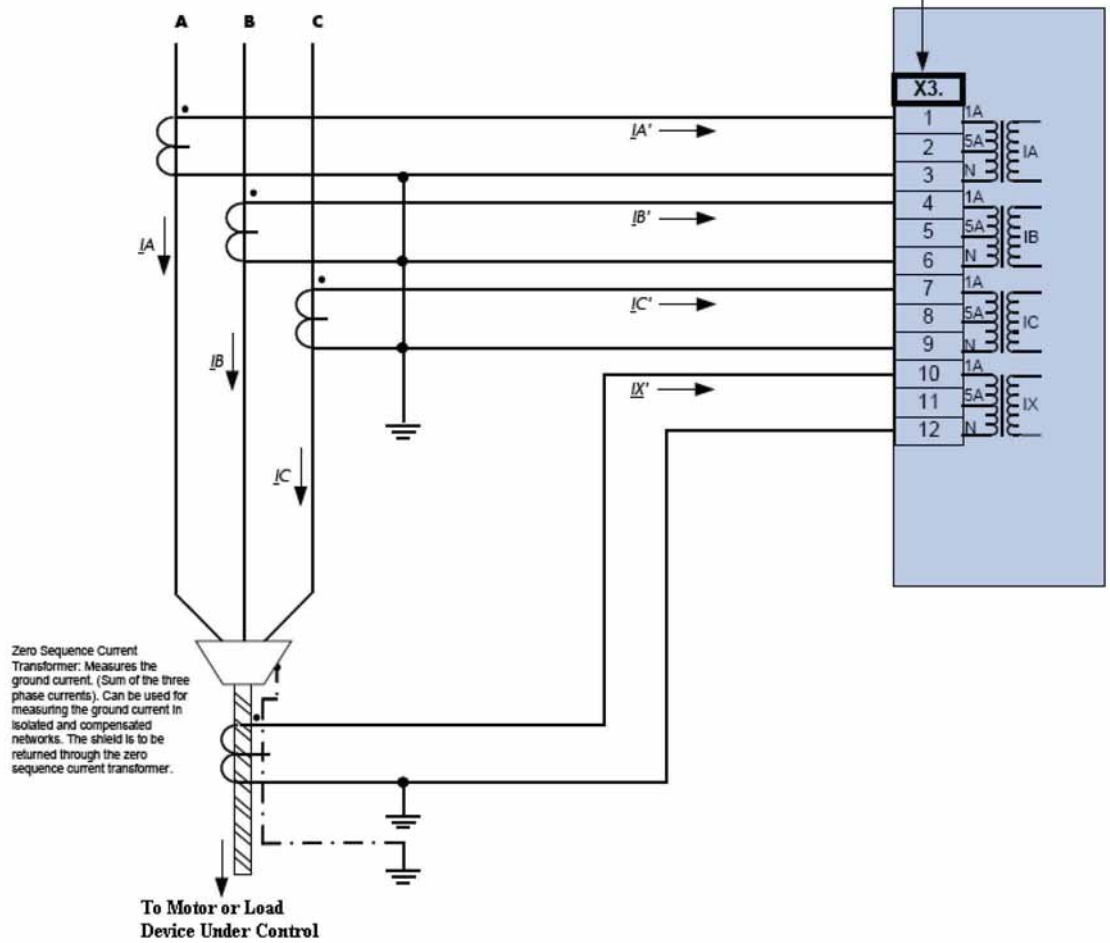

Three Phase Current Measurement; I_{nom} Secondary = 1 A.
Ground Current Measuring via Zero Sequence CT ; I_{Gnom} Secondary = 1 A.

Typical One-Line Diagram

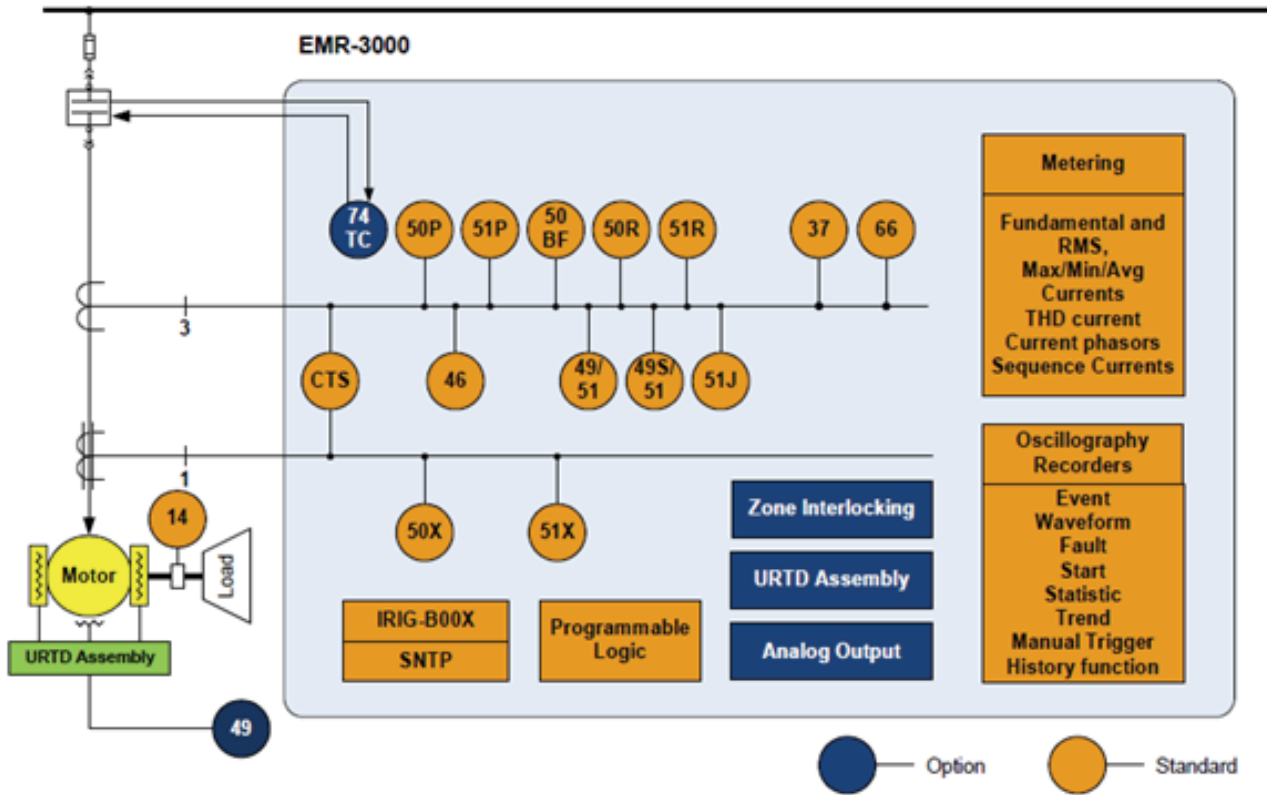

9.3

Metering Devices, Protective Relays, Software and Connectivity

Protective Relays

Typical Control Diagram

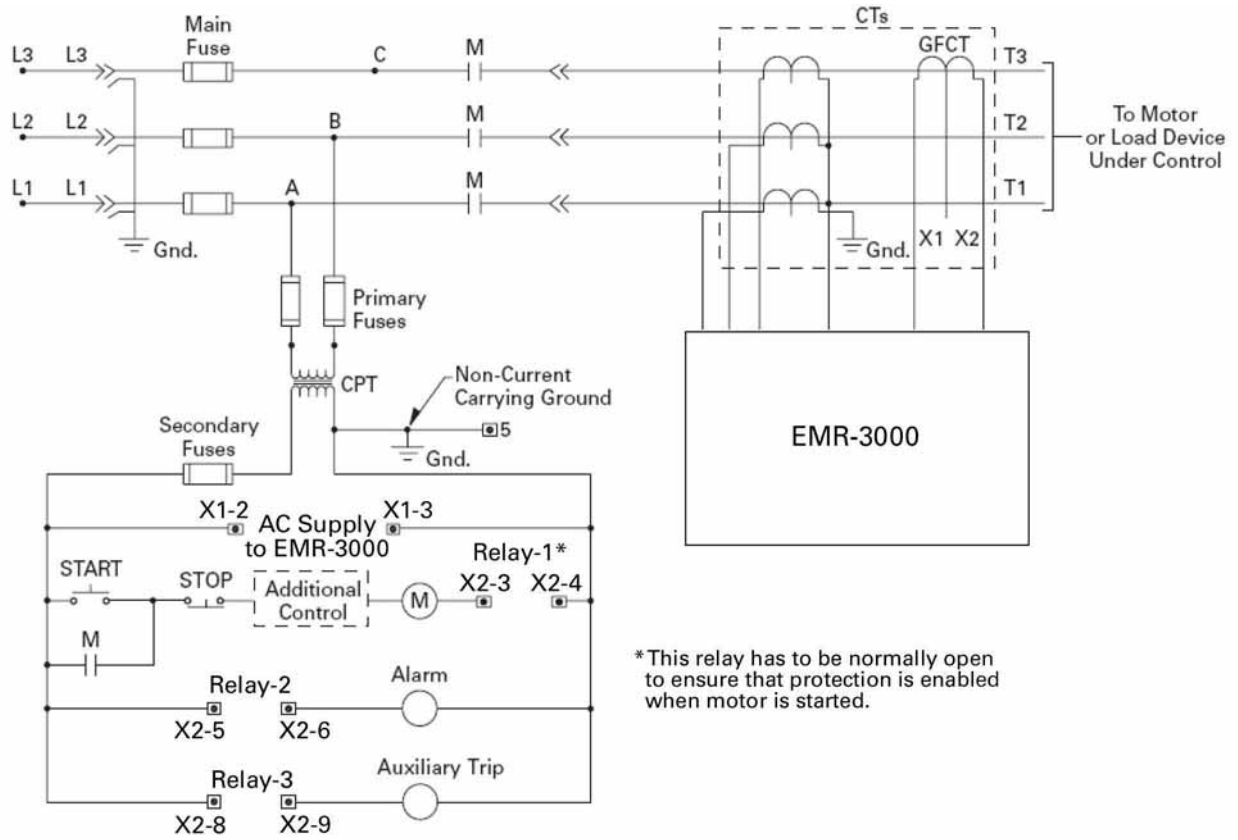

Dimensions

Approximate Dimensions in Inches (mm)

Drilling Plan

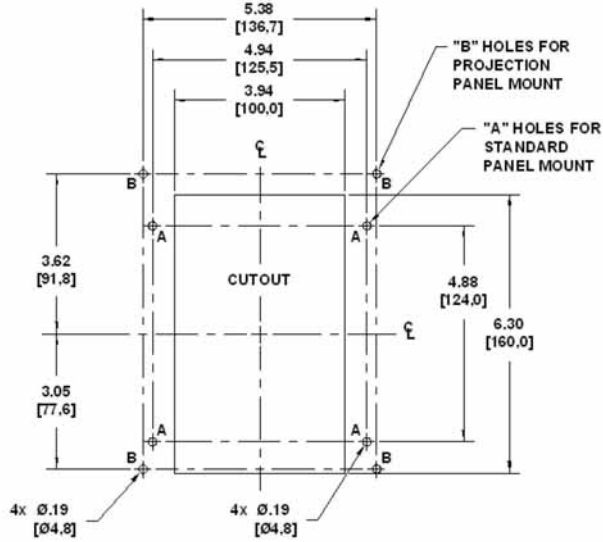

Projection Mount Front and Side Views

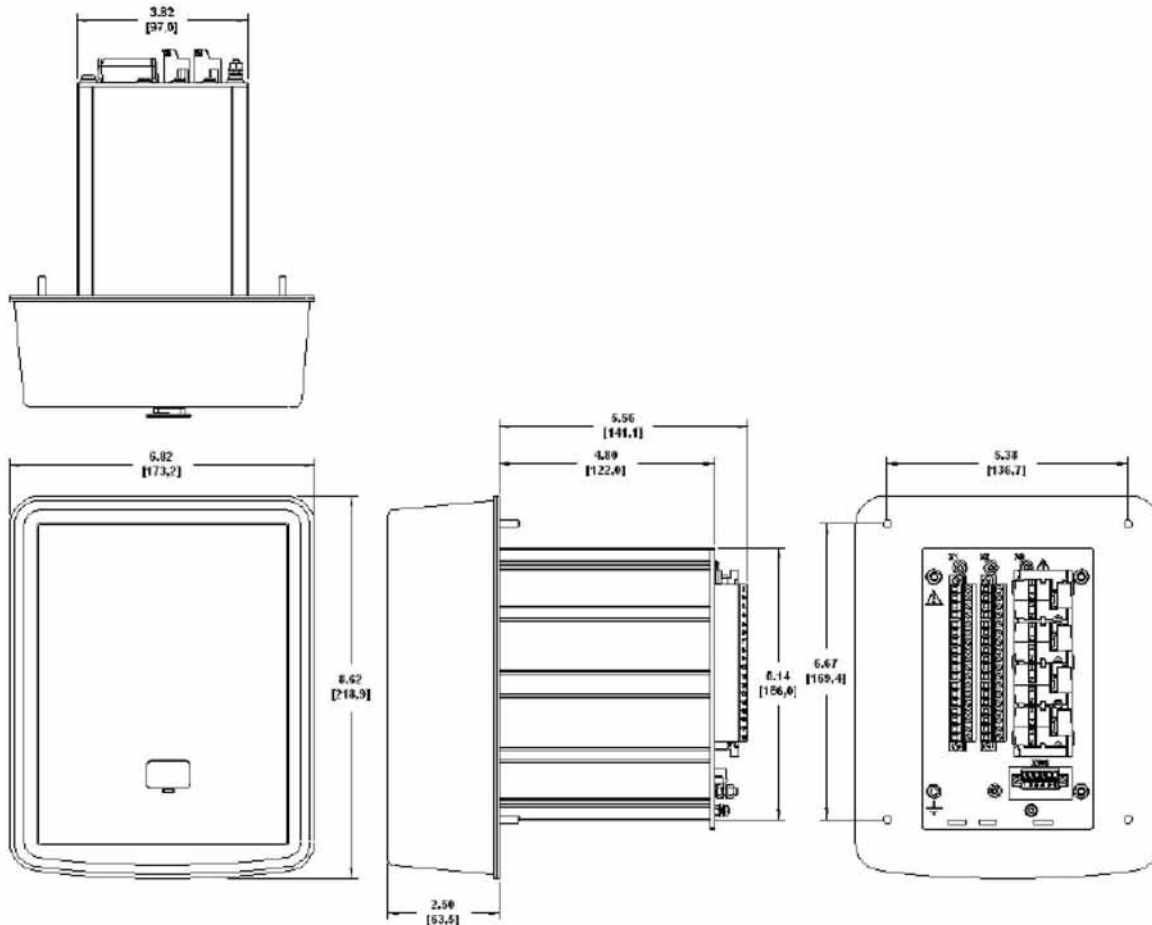

9.3

Metering Devices, Protective Relays, Software and Connectivity

Protective Relays

Approximate Dimensions in Inches (mm)

Standard Mount Front and Side Views

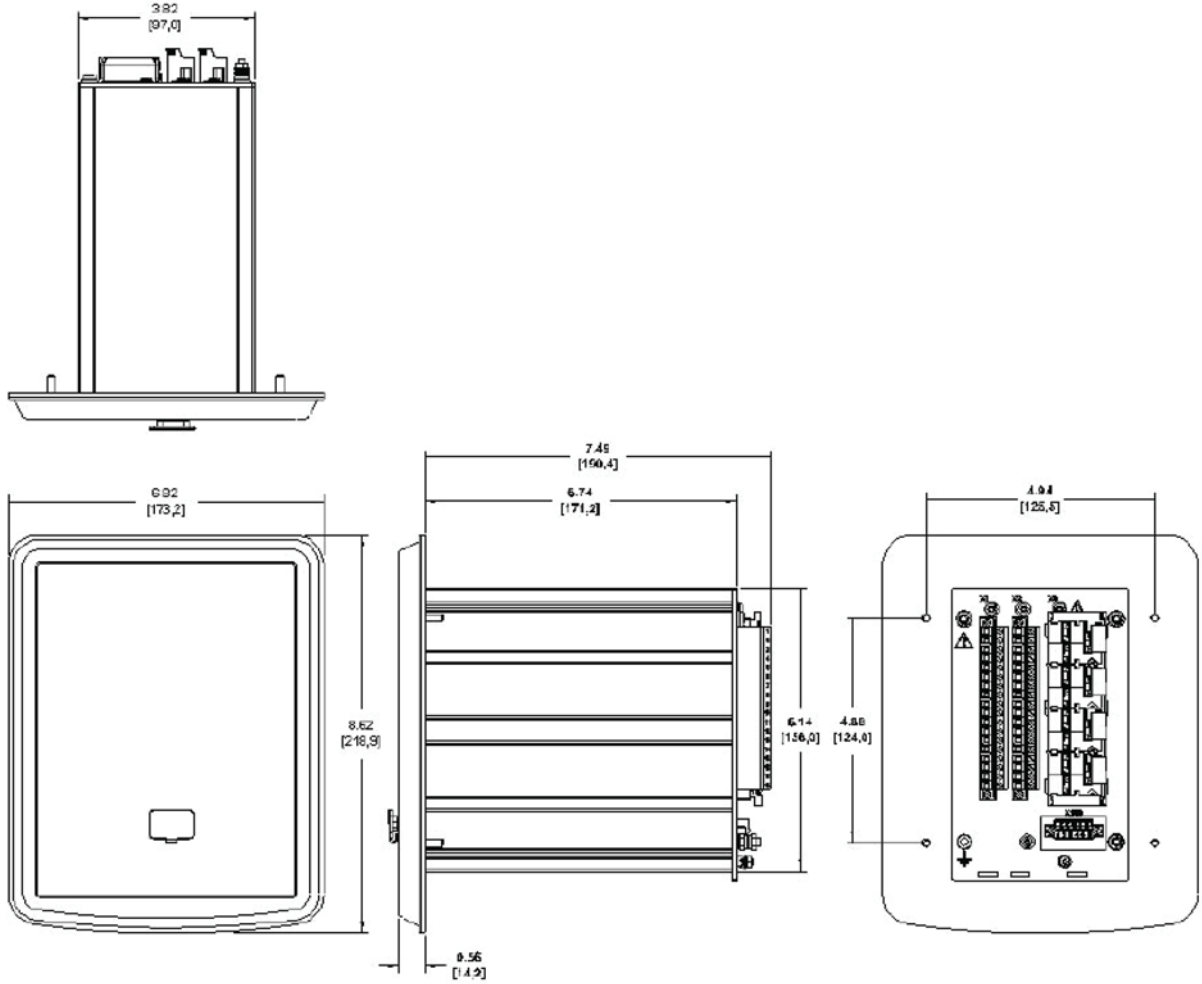

EMR-4000 Motor Protection Relay



Contents

<i>Description</i>	<i>Page</i>
Product Selection Guide	V3-T9-117
Digitrip 3000	V3-T9-123
EDR-3000 Feeder Protection	V3-T9-133
EDR-5000 Distribution Protection Relay	V3-T9-142
FP-5000 Feeder Protection	V3-T9-155
MP-3000 Motor Protection	V3-T9-163
MP-4000 Motor Protection	V3-T9-173
EMR-3000 Motor Protection Relay	V3-T9-179
EMR-4000 Motor Protection Relay	V3-T9-204
EMR-5000 Motor Protection Relay	V3-T9-216
ETR-4000 Transformer Protection Relay	V3-T9-228
EGR-5000 Generation Protection Relay	V3-T9-241
Ground Fault Relay	V3-T9-254
Universal RTD Module	V3-T9-257

EMR-4000 Motor Protection Relay

Product Description

Eaton’s EMR-4000 motor protection relay is a multifunctional microprocessor-based protective relay for the protection of any size motor at all voltage levels. It is most commonly applied on medium voltage or larger motors. The EMR-4000 relay is a current and voltage device that provides complete and reliable motor protection, monitoring, diagnostics, metering and starting control functions.

The EMR-4000 motor protection relay has removable terminal blocks, and it has Modbus-RTU communications as standard; and an optional Ethernet port for Modbus-TCP communications or IEC-61850.

The EMR-4000 motor protection relay provides complete current, voltage, and frequency protection in a single compact case. The relay has four current inputs rated for either 5 amperes or 1 ampere and four voltage

inputs. Three of the voltage inputs are to be connected to the three-phase power voltage for voltage protection and for metering. They can be connected in wye-ground or open delta configuration. The fourth voltage is for independent single-phase undervoltage/overvoltage protection. The unit is capable of 60 Hz or 50 Hz operation.

The maintenance mode password protected soft key, can be used for arc flash mitigation to change to an alternate settings group, set to have instantaneous elements only. The multiple setting groups can also be changed, via communications or a digital input. Flash memory is used for the programming and all settings are stored in nonvolatile memory.

An integral keypad and display is provided for direct user programming and retrieval of data without the need of a computer. 14 programmable LEDs provide quick indication of relay status.

A front port is provided for direct computer connection. An RS-485 communication port on the back is standard for local area networking using Modbus-RTU. An optional Ethernet port and protocols are available.

The EMR-4000 motor protection relay includes programmable logic functions. Logic gates and timers may be defined and arranged for customized applications. With the programmable logic control functions you can simplify the complexity of your starting schemes by eliminating timers and auxiliary relays. Flash memory is used for the programming and all settings are stored in nonvolatile memory. The relay allows for four preprogrammed setting groups which can be activated through software or contact input.

The EMR-4000 motor protection relay has mass memory for data storage and a real-time clock with 1 ms time resolution.

The relay will log 300 sequence of event records, 20 detailed trip logs, minimum/maximum values, load profiles, the 5 latest start profiles, motor trending, breaker/contact wear information and oscillography data.

The EMR-4000 motor protection relay has eight discrete inputs, 1 fiber optic input, 2 Form C, and 2 NO output programmable contacts, and 1 Form C healthy contact. It also has four 4-20 mA analog outputs and one zone interlocking card. The relay provides maximum user flexibility to configure the I/O. All inputs and outputs (except the healthy output) are user-programmable. The unit also counts with a test mode to force outputs and simulate currents, to facilitate the commissioning of the unit. It can be powered from 19 Vdc to 300 Vdc or 40 Vac to 250 Vac auxiliary power.

Application Description

Eaton's EMR-4000 motor protection relay has been designed for maximum motor operation and protection. It permits running the motor close to its design limits while protecting it against excessive heating and damaging overload conditions. The EMR-4000 field proven protection algorithms were developed based on motor designs and operating parameters for optimum operation and protection while minimizing nuisance tripping. The EMR-4000 motor protection relay utilizes a patented protection algorithm and measurement technique based on proven positive and negative (unbalance) sequence current sampling and true RMS calculations.

Features, Benefits and Functions

Intel-I-Trip (I²t) Overload Protection

The EMR-4000 motor relay features the exclusive Eaton Intel-I-Trip intelligent overload protection system. Intel-I-Trip develops custom overload curves simply from motor nameplate data. Intel-I-Trip protects motors from potentially damaging overload and abnormal operating conditions. The Intel-I-Trip intelligent overload protection feature utilizes field proven measurement techniques and a patented motor thermal protection model. The EMR-4000 motor relay's unique measurement technique samples the current waveforms 36 times per cycle, providing accurate measurements of the positive and negative sequence currents. The negative sequence current causes a greater heating effect on the rotor and has a greater impact on the thermal model in the relay. Intel-I-Trip utilizes these measurements in its motor model to safely protect the motor against the heating effects of these currents.

The motor thermal model is analogous to a bucket that is being filled and drained at the same time. The fill rate is dependent on the motor currents and the drain is based on motor design principles. The size of the bucket is equivalent to the thermal capacity associated with the mass of the motor. Intel-I-Trip integrates these rates and will issue a trip when the thermal capacity is filled.

Intel-I-Trip features adaptive trip characteristics that adjust the trip times based on measured motor temperature when RTDs are used.

Instantaneous Overcurrent

The EMR-4000 motor protection relay provides an instantaneous phase overcurrent function to trip the motor for high fault current levels and save the fuses. This function can be disabled and has an adjustable time delay on starting to avoid nuisance tripping on inrush.

Phase Unbalance Protection

Motor supply circuits are often fed through fuses and can be run with a single-phase fuse blown, referred to as single phasing the motor. The EMR-4000 motor protection relay measures the current and voltage unbalance and either can be used to alarm or trip the motor before damage occurs. The EMR-4000 has 2 voltage and 2 current unbalance elements. Pickup, start and run timers are provided for each element.

Ground Fault Protection

A separate measuring circuit is used to measure ground current. A ground CT is recommended for more sensitive protection against winding insulation breakdown to ground. The relay ground circuit can be connected residually from the three-phase CTs. The ground fault protection has pickup and time delay set points or can be disabled.

Jam Protection

The user-selectable Jam function protects motors that are running against a sudden mechanical jam or stall condition. The common application is on motors used on crushers, chippers, or conveyors. It detects an increase of motor current to a level above full load. Pickup, start, and run timers and a second element for alarm purposes are provided.

Underload/Underpower Protection

The user selectable underload/underpower function is used to detect the loss of load on the motor. Coupling failure is a common cause for loss of load. Whenever is possible, it is better to use underpower to detect loss of load. Three power elements and two underload elements are provided in the relay for tripping and alarm purposes. Pickup, start, and run timers are provided for each element.

Frequency Protection

The frequency elements provide the ability to detect when the motor is operating at off-nominal frequencies that can do damage to the process or, to signal to upstream protections or controls to implement load shedding actions.

Power Factor Protection

This protection is used in synchronous motors applications to detect out-of-synchronism conditions.

Undervoltage/Overvoltage Protection

Use the voltage protective functions to detect abnormal system voltage conditions potentially hazardous to the motor.

Reduced Voltage Starting

The EMR-4000 motor protection relay provides a transition and incomplete sequence function for reduced voltage starting. The user can select to transition based on the current level and/or on time.

Antibackspin

The stop function is programmable from 2 to 20%. For certain applications, such as pumping a fluid up a pipe, the motor may be driven backward for a period of time after it stops. The EMR-4000 relay provides an antibackspin timer to prevent starting the motor while it is spinning in the reverse direction. The timer begins counting from the moment a stop is declared by the relay.

Start Control Timers

Motors typically have limits to the number of cold starts, starts per hour period, or time between starts that are permitted without damage. The EMR-4000 motor protection relay incorporates these timers to prevent starting the motor beyond its capabilities.

Load Shedding

The EMR-4000 motor protection relay provides a mechanical load shedding feature that can be used to control an upstream process. The load-shedding function closes a contact on an overload condition to control an upstream process from adding more load until the overload condition is gone.

Emergency Override

The EMR-4000 motor protection relay has a user-programmable feature that will let the operator reset the start inhibitor timers and thermal overload bucket. This function is intended for use in emergency conditions only, and it may result in motor damage or failure.

Long Acceleration Motors

Large motors with a high inertia may experience starting currents that exceed the locked rotor current and time. The EMR-4000 motor protection relay has logic and provisions for a zero speed switch input to differentiate between a stall and start condition. If the motor is spinning, then the relay will not trip on the normal locked rotor time allowing the motor to start.

Remote/differential Trip

The digital inputs can be programmed to accept a contact input from a separate differential relay or other device to trip the motor. This provides local and remote target information and utilizes the trip contacts of the EMR-4000 motor protection relay. It will also record and log the motor information at the time of the trip.

Breaker Failure or Stuck Contactor

The EMR-4000 motor protection relay includes a breaker failure (50BF, 62BF) function that can be initiated from either an internal or external trip signal. This is an independent element that can be used to operate a lockout relay or trip an upstream breaker. The timer must be longer than the breaker operating time and the protective function reset times.

Flexible Phase Rotation

The EMR-4000 motor protection relay can be applied on either an A-B-C or A-C-B phase rotation. A user setting permits correct operation and indication of the actual system configuration.

Maintenance Mode

The Maintenance Mode can improve safety by providing a simple and reliable method to reduce fault clearing time and lower incident energy levels at energized panels. The Maintenance Mode allows the user to switch to more sensitive settings via a password protected soft key, communication or via a digital input while maintenance work is being performed at an energized panel or device. The more sensitive settings provide greater security for maintenance personnel and helps reduce the possibility of injury.

Diagnostic Features

Broken Rotor Bar

The EMR-4000 provides advanced motor diagnostics including a broken rotor bar detection function. The broken rotor bar detection is a condition maintenance function that continuously monitors the motor's health while in operation. The advanced Motor Current Signature Analysis (MCSA) continuously analyzes the motor current signature and based on preset algorithms will determine when a broken rotor bar is present in the motor.

The broken rotor bar function will provide early detection of any rotor problems and advise maintenance personnel of the impending issue allowing for predictive maintenance of the motor and prevention of catastrophic motor failures.

By providing early indication of potential rotor problems, serious system issues such as: reduced starting torque, overloads, torque and speed oscillation and bearing wear can be avoided. With the advanced broken rotor bar detection system, advanced warning of impending problems reduces catastrophic failures, maximizing motor life and system uptime.

Protection Features

- Thermal protection (49/51)
 - Locked rotor protection (49S/51)
- Phase overcurrent elements:
 - Two instantaneous elements with timers (50P[1], 50P[2] and 50P[3])
 - Three inverse time overcurrent elements (51P[1], 51P[2] and 51P[3])
 - 11 standard curves
 - Instantaneous or time delay reset
- Ground overcurrent elements:
 - Two instantaneous measured elements with timers (50X[1] and 50X[2])
 - Two instantaneous calculated elements with timers (50R[1] and 50R[2])
 - Two inverse time overcurrent measured elements (51X[1] and 51X[2])
 - Two inverse time overcurrent calculated elements (51R[1] and 51R[2])
 - 11 standard curves
 - Instantaneous or time delay reset
- Jam or Stall protection (50J[1], 50J[2])
- Phase unbalance negative sequence overcurrent (46[1], 46[2])
- Underload protection (37[1], 37[2])
- Temperature protection with optional URTD (49/38)
- Stars per hour (66)
- Switch onto fault protection
- Phase voltage unbalance and sequence protection (47[1], 47[2])
- Main three-phase under/overvoltage (27M[1], 27M[2], 59M[1], 59M[2])

- Auxiliary single-phase under/overvoltage (27A[1], 27A[2], 59A[1], 59A[2])
- Six frequency elements that can be assigned to: over frequency, under frequency, rate of change, or vector surge (81[1], 81[2], 81[3], 81[4], 81[5], 81[6])
- Apparent and displacement power factor (55A[1], 55A[2], 55D[1], 55D[2])
- Forward and reverse Watts (32[1], 32[2], 32[3])
- Forward and reverse VARs (32V[1], 32V[2], 32V[3])
- Lockout protection (86)
- Breaker failure (50BF)
- Zone interlocking for bus protection (87B)

Metering Features

- Amperes: Positive, negative and zero sequence
- Volts: Positive, negative and zero sequence
- Phase angles
- Volt-amperes and VA demand
- Watts and kW demand
- kWh (forward, reverse, net)
- VARs and kVAR demand
- kVARh (lead, lag and net)
- Power factor
- Frequency
- % THD V and I
- Magnitude THD V and I
- Minimum/maximum recording
- Trending (load profile over time)
- Minimum/maximum recording
- Temperature with remote URTD module

Monitoring Features

- Trip coil monitor
- Breaker wear primary and secondary (accumulated interrupted current)
- Oscillography (7200 cycles total)
- Trip Cause displays fault recorder data on HMI after fault event
- Fault data logs (up to 20 events)
- Sequence of events report (up to 300 events)
- Trending (load profile over time)
- Motor history
- Records the last 5 motor start profiles
- Motor start trending
- CT supervision
- VT supervision
- Clock (1 ms time stamping)

Diagnostic Features

- Broken rotor bar

Control Functions

- Transition for reduced voltage starts
- Incomplete sequence delay
- Permits numbers of cold starts
- Limits numbers of starts per hour
- Anti-backspin time delay
- Mechanical load shedding
- Zero speed switch for long acceleration motors
- Motor stop inputs
- Remote trip input
- Differential trip input
- Emergency override
- Breaker/contactors open-close/stop-start
- Remote open-close (stop-start)
- Programmable I/O
- Programmable LEDs
- Programmable logic
- Multiple setting groups

Communication Features

- Local HMI
- Password protected
- Addressable.
- IRIG-B
- Local communication port.
 - RS-232
- Remote communication port:
 - RS-485
 - Ethernet port
- Protocols:
 - Modbus-RTU (optional)
 - Modbus-TCP (optional)
 - IEC-61850 (optional)
- Configuration software

Monitoring and Metering

Sequence of Events Records

The EMR-4000 protection relay records a maximum of 300 events associated with the relay. An event is classified as a change of state as detected by the relay. These include relay pickups, dropouts, trips, contact closure, alarms, setting changes and self-diagnostic failures. Each event is date and time stamped to a 1 ms resolution. The events are stored in a FIFO in chronological order.

Trip Log

The EMR-4000 protection relay will store a maximum of 20 trip records in a FIFO trip log. Each trip record will be date and time stamped to a 1 ms resolution. The trip log record will include information on the type of fault, protection elements that operated, fault location and currents and voltages at the time of the fault.

PowerPort-E

PowerPort-E is the software program used to configure off-line protection setting files for all E-Series relay models. PowerPort-E is also used for viewing measured values of the relays in real-time, uploading/downloading setting files, and retrieving event log and waveform records.

Waveform Capture (Quality Manager)

The EMR-4000 relay provides oscillographic recording capabilities. The relay will record all measured signals along with the binary signals of pickup, trip, internal logic, and contact inputs. The EMR-4000 can record up to 7200 cycles of data. The number of records is proportional to the programmed size of each record; the maximum size per record is 600 cycles. The

waveform capture is initiated by up to 8 different triggers (i.e., trip/alarm events) or manually via communications or the HMI. PowerPort-E setting software is used to retrieve the records. Quality Manager is a separate software program downloaded with PowerPort-E used for analyzing the waveform and trending files retrieved from the relay.

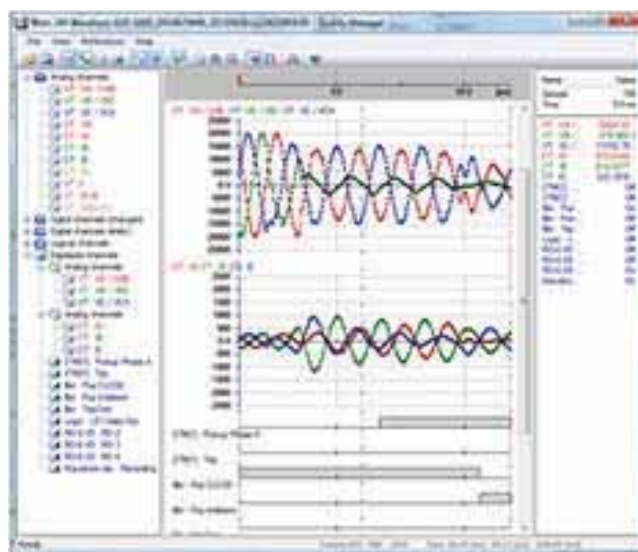
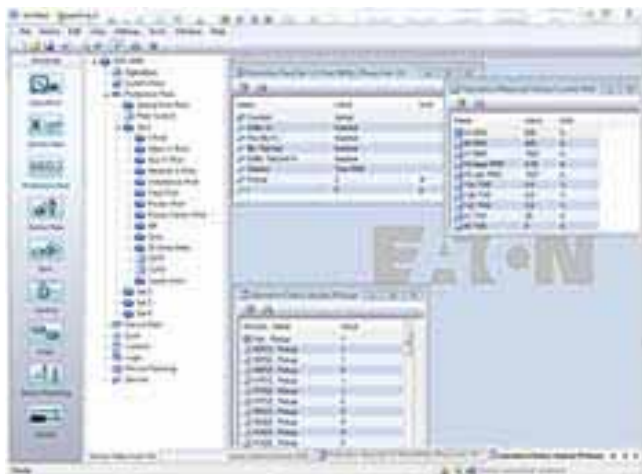

Integral User Interface

The front panel user interface has a 128 x 64 pixel LCD display with background illumination for wide angle viewing in all light conditions. Seven programmable LEDs provide quick and easy visual display of power on, mode of operation, alarm and trip indication. Soft keys are provided for operation mode selection, scrolling through data and settings. In addition, the relay settings and test functions are password protected.

Starting Profiles

The EMR-4000 records the average current versus time for the last five starting cycles. This information is available via the communications port through PowerPort-E

Motor Statistics

For each motor start, the EMR-4000 stores a motor start report and add this data to the motor statistics buffer. With the motor statistics you can track motor start data for the past eighteen 30-day periods. For each 30-day interval, the relay records the following information:

- The date the interval began
- The total number of starts in the interval
- The averages of the following quantities:
 - Motor start time
 - Start % rotor thermal capacity used
 - Maximum start current

Load Profiling/Trending

The EMR-4000 relay automatically records selected quantities into non-volatile memory every 5, 10, 15, 30, or 60 minutes, depending on the trending report setting.

Programmable I/O

The EMR-4000 motor protection relay provides heavy-duty, trip-rated, 2 normally open and 1 Form C contacts. One isolated inputs can be used for monitoring the trip circuit. One Form C contact is dedicated to the relay failure alarm function and is operated in a normally energized (failsafe) mode. There are 4 eight user-configurable discrete inputs that accept a wet contact and can operate through a wide range of power. Each input and output is user-programmable for maximum application flexibility.

Programmable Logic

The EMR-4000 motor protection relay provides logic gates and timers that the user can customize for special or unique applications. Each gate can be assigned a logic function of either AND, OR, NAND or NOR. Each gate can have a maximum of four input signals and each input signal can be required to be a NOT. Input signals can be external inputs received via the binary inputs or internal values associated with the protection, alarm or metering set points. Each gate has a unique output assignment and designation that can be used as the input to another gate. There are 80 independent timers that have adjustable pickup and dropout delay settings.

Standards and Certifications**Design Standards**

- Generic Standard:
 - EN 61000-6-2
 - EN 61000-6-3
- Product Standard:
 - IEC 60255-6
 - EN 50178
 - UL 508 (Industrial Control Equipment)
 - CSA C22.2 No. 14-95 (Industrial Control Equipment)
 - ANSI C37.90



Catalog Number Selection

The catalog number identification chart defines the electrical characteristics and operation features included in the EMR-4000. For example, if the catalog number were EMR-4000-2A0BA1, the device would have the following:

EMR-4000

(A)—Four digital inputs, four output relays, 1 4-20 mA analog output, URTD interface

(0)—5 A / 1 A phase and ground CTs, power supply range: 19–300 Vdc, 40–250 Vac

(B)—Modbus-RTU (RS-485)

(A)—Without conformal coating

(1)—Projection panel mount

Motor Relay Removable Terminals

EMR-4000-2A 0 B A 1

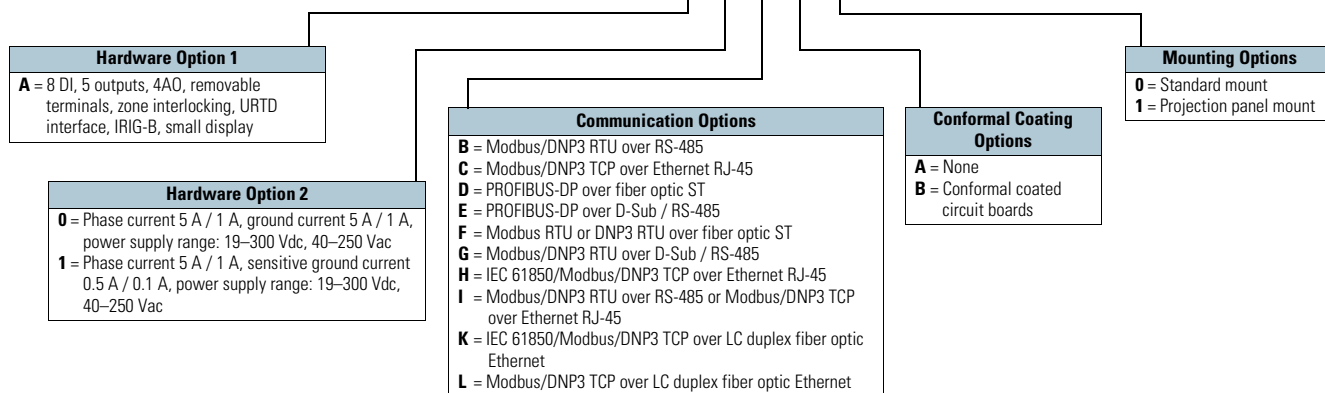

Accessories

Standard Accessories EMR-4000

Description	Catalog Number
UNVL RTD Mod with Modbus-RTU 48–240 Vac/48–250 Vdc	URTDII-01 ^①
UNVL RTD Mod with Modbus-RTU 24–48 Vdc	URTDII-02 ^①

Note

^① See URTD section for fiber optic cables required to communicate to the EMR-3000.

Technical Data and Specifications**Climatic Environmental Conditions**

- Storage temperature: -30 °C to +70 °C (-22 °F to +158 °F)
- Operating temperature: -20 °C to +60 °C (-4°F to +140 °F)
- Permissible humidity at ann. average: <75% rel. (on 56d up to 95% rel.)
 - Permissible Installation Altitude: <2,000 m (6,561.67 ft) above sea level
- If 4,000 m (13,123.35 ft) altitude applies, a changed classification of the operating and test voltages may be necessary

Degree of Protection EN 60529

- HMI front panel with seal: IP54
- Rear side terminals: IP20

Routine Test

- Insulation test acc. to IEC 60255-5: All tests to be carried out against ground and other input and output circuits
- Aux. voltage supply, digital inputs, current measuring inputs, signal relay outputs: 2.5 kV (eff.) / 50 Hz
- Voltage measuring Inputs: 3.0 kV (eff.) / 50 Hz
- All wire-bound communication interfaces: 1.5 kV DC

Housing

- Housing B2: height / width 183 mm (7.205 in)/ 212.7 mm (8.374 in)
- Housing depth (Incl. Terminals): 208 mm (8.189 in)
- Material, housing: aluminum extruded section
- Material, front panel: aluminum/foil front
- Mounting position: horizontal ($\pm 45^\circ$ around the X-axis must be permitted)
- Weight: approx. 4.2 kg (9.259 lb)

Current and Ground Current Measurement

- Nominal currents: 1 A / 5 A
- Max. measuring range:
 - Up to 40 x In (phase currents)
 - Up to 25 x In (ground current standard)
 - Up to 2.5 x In (ground current sensitive)
- Continuous loading capacity: 4 x In/ continuously
- Overcurrent proof:
 - 30 x In / 10 s
 - 100 x In / 1 s
 - 250 x In / 10 ms (1 half-wave)
- Power consumption:
 - Phase current inputs At In= 1 A S=0.15 MVA At In= 5 A S=0.15 MVA
 - Ground Current Input At In= 1 A S=0.35 MVA At In= 5 A S=0.35 MVA
- Frequency range: 50 Hz / 60 Hz $\pm 10\%$
- Terminals: screw-type terminals with integrated short-circuiters (contacts)
- Connection cross sections:
 - 1 x or 2 x 2.5 mm² (2 x AWG 14) with wire end ferrule
 - 1 x or 2 x 4.0 mm² (2 x AWG 12) with ring cable sleeve or cable sleeve
 - 1 x or 2 x 6 mm² (2 x AWG 10) with ring cable sleeve or cable sleeve
 - The current measuring board's terminal blocks may be used as with 2 (double) conductors AWG 10,12,14 otherwise with single conductors only

Plug-in Connector with Integrated Short-Circuiter (Conventional Current Inputs)

- Nominal currents: 1 A / 5 A
- Continuous loading Capacity: 4 x In / continuously
- Overcurrent withstand:
 - 30 x In / 10 s
 - 100 x In / 1 s
 - 250 x In / 10 ms (1 half-wave)
- Screws: M4, captive type acc. to VDEW
- Connection cross sections:
 - 1 x or 2 x 2.5 mm² (2 x AWG 14) with wire end ferrule
 - 1 x or 2 x 4.0 mm² (2 x AWG 12) with ring cable sleeve or cable sleeve
 - 1 x or 2 x 6 mm² (2 x AWG 10) with ring cable sleeve or cable sleeve
 - The current measuring board's terminal blocks may be used as with 2 (double) conductors AWG 10,12,14 otherwise with single conductors only

Control Power Supply

- Aux. voltage: 240–270 Vdc / 48–230 Vac (-20/+10%)
- Buffer time in case of supply failure: ≥ 50 ms at minimal aux. voltage Interrupted communication is permitted
- Max. permissible making current:
 - 18 A peak value for <0.25 ms
 - 12 A peak value for <1 ms
- The voltage supply must be protected by a fuse of:
 - 2.5 A time-lag miniature fuse approx. 1/5 x 0.8 in (5 x 20 mm) according to IEC 60127
 - 3.5 A time-lag miniature fuse approx. 1/4 x 1 1/4 in (6.3 x 32 mm) according to UL 248-14

Voltage and Residual Voltage Measurement

- Nominal voltages: 100 V / 110 V / 230 V / 400 V (can be configured)
- Max. measuring range: 2 x nominal voltage
- Continuous loading capacity: 2 x nominal voltage (800 Vac)
- Power Consumption:
 - at Vn = 100 V S = 0.1 MVA
 - at Vn = 110 V S = 0.1 MVA
 - at Vn = 230 V S = 0.4 MVA
 - at Vn = 400 V S = 1.0 MVA
- Frequency range: 50 Hz or 60 Hz $\pm 10\%$
- Terminals: screw-type terminals

Frequency Measurement

- Nominal Frequencies: 50 Hz / 60 Hz

Voltage Supply

- Aux. Voltage: 24–270 Vdc / 48–230 Vac (-20/+10%)
- Buffer time in case of supply failure:
 - ≥ 50 ms at minimal aux. voltage
 - Interrupted communication is permitted.
- Max. permissible making current:
 - 18 A peak value for 0.25 ms
 - 12 A peak value for 1 ms
- The voltage supply must be protected by a fuse of:
 - 2.5 A time-lag miniature fuse approx. 5 x 20 mm (0.2 x 0.8 in) according to IEC 60127
 - 3.5 A time-lag miniature fuse approx. 6.3 x 32 mm (0.25 x 1.25 in) according to UL 248-14

Power Consumption

- Power supply range: 24–270 Vdc
 - Power consumption in idle mode—7 W
 - Maximum power consumption—13 W
- Power supply range: 48–230 Vac (for frequencies of 40–70 Hz)
 - Power consumption in idle mode—7 W
 - Maximum power consumption—13 W

Display

- Display Type: LCD with LED background illumination
- Resolution—graphics display: 128 x 64 pixel
- LED type: two colored: red/green
- Number of LEDs, housing B2: 15

Front Interface

- Baud Rates: 115,200 baud
- Handshake: RTS and CTS
- Connection: 9-pole D-Sub plug

Real Time Clock

- Running reserve of the real time clock: 1 year min.

Digital Inputs

- Max. input voltage: 300 Vdc / 259 Vac
- Input current: <4 mA
- Reaction time: <20 ms
- Fallback time: <30 ms
- (Safe State of the Digital Inputs)
- Four switching thresholds:
 - $U_n = 24 \text{ Vdc}$
 - Switching threshold 1 ON: Min. 19.2 Vdc
 - Switching threshold 1 OFF: Max. 9.6 Vdc
 - $U_n = 48 \text{ V} / 60 \text{ Vdc}$
 - Switching threshold 2 ON: Min. 42.6 Vdc
 - Switching threshold 2 OFF: Max. 21.3 Vdc
 - $U_n = 110 / 120 \text{ Vac} / \text{Vdc}$
 - Switching threshold 3 ON: Min. 88.0 Vdc / 88.0 Vac
 - Switching threshold 3 OFF: Max. 44.0 Vdc / 44.0 Vac
 - $U_n = 230 / 240 \text{ Vac} / \text{Vdc}$
 - Switching threshold 4 ON: Min. 184 Vdc / 184 Vac
 - Switching threshold 4 OFF: Max. 92 Vdc / 92 Vac
- Terminals: screw-type terminal

Relay Outputs

- Continuous current: 5 A AC/DC
- Max. make current:
 - 25 A AC / 25 A DC up to 30 V for 4 s
 - 30 A / 230 Vac according to ANSI IEEE Std C37.90-2005
 - 30 A / 250 Vdc according to ANSI IEEE Std C37.90-2005
- Max. breaking current:
 - 5 A AC up to 250 Vac
 - 5 A DC up to 30 V (resistive)
 - 0.3 A DC at 300 V
- Max. switching voltage: 250 Vac / 250 Vdc
- Switching capacity: 1250 VA
- Contact Type: Form C or normally open contact
- Terminals: screw-type terminals

9.3

Metering Devices, Protective Relays, Software and Connectivity

Protective Relays

Wiring Diagrams

Typical AC Connections, Wye VTs 5 A CTs and Ground Current Measured by Residual Connection

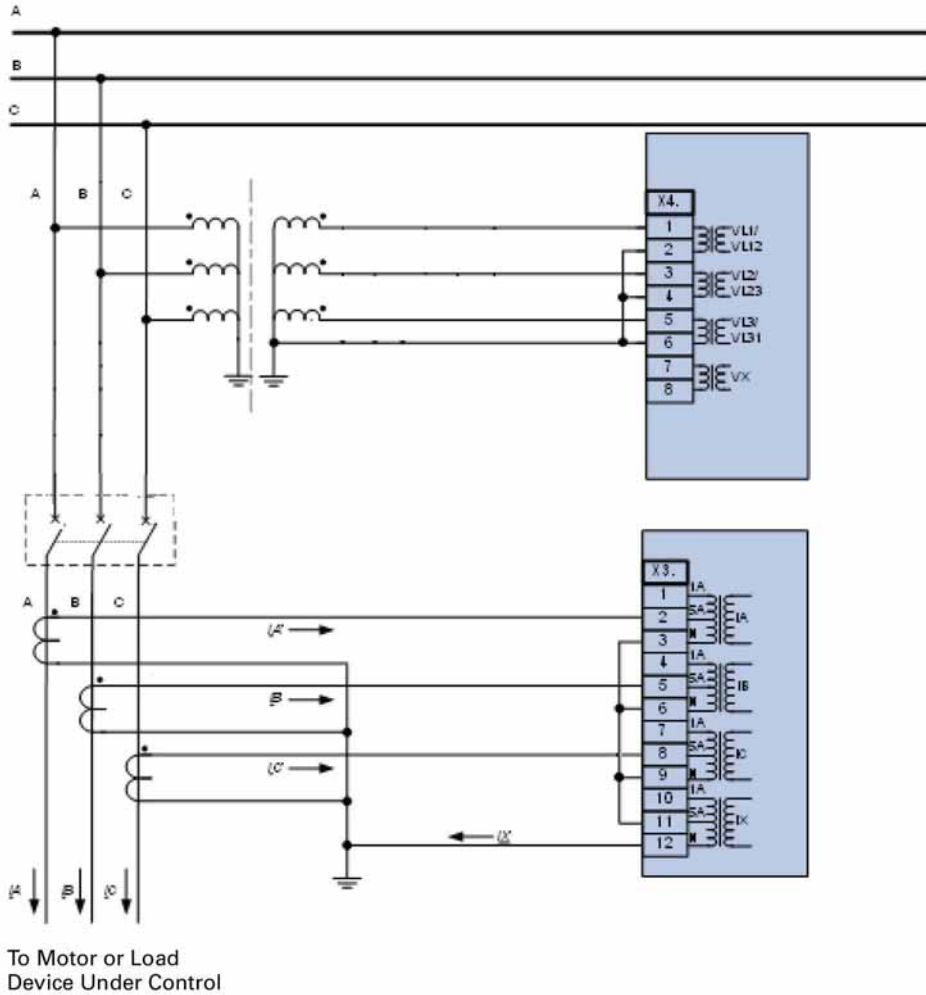

Typical Control Diagram

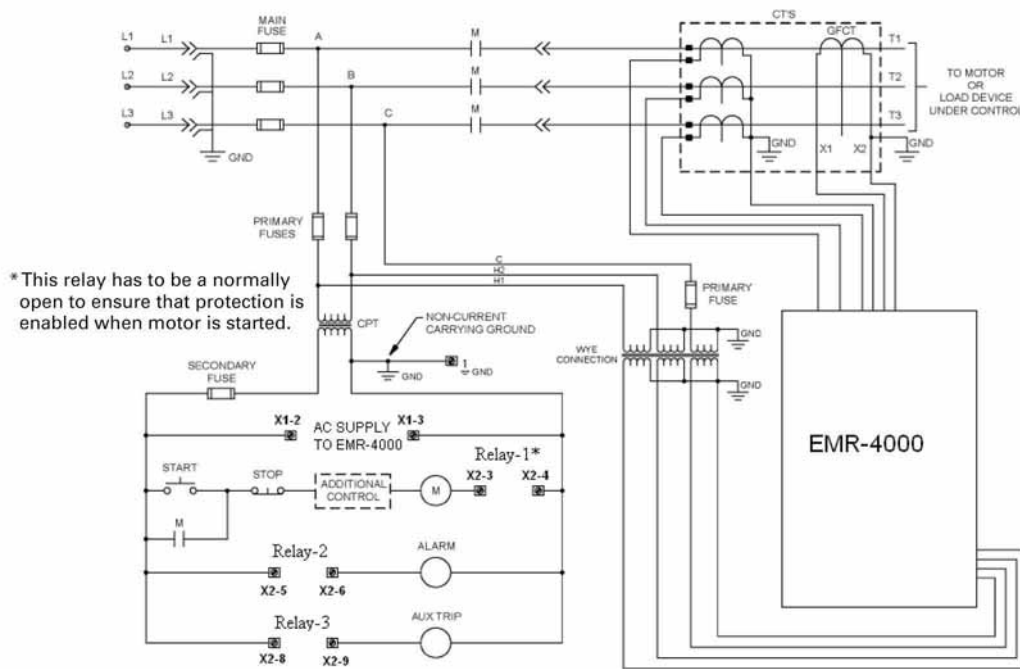

Dimensions

Approximate Dimensions in Inches (mm)

Drilling Plan

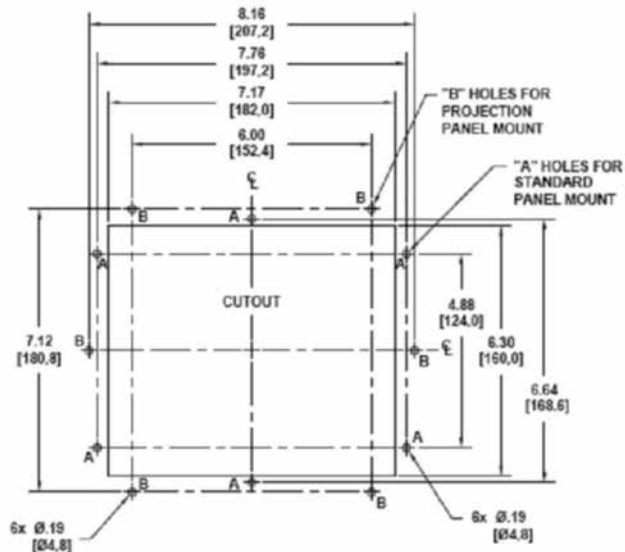

Projection Mount Front and Side Views

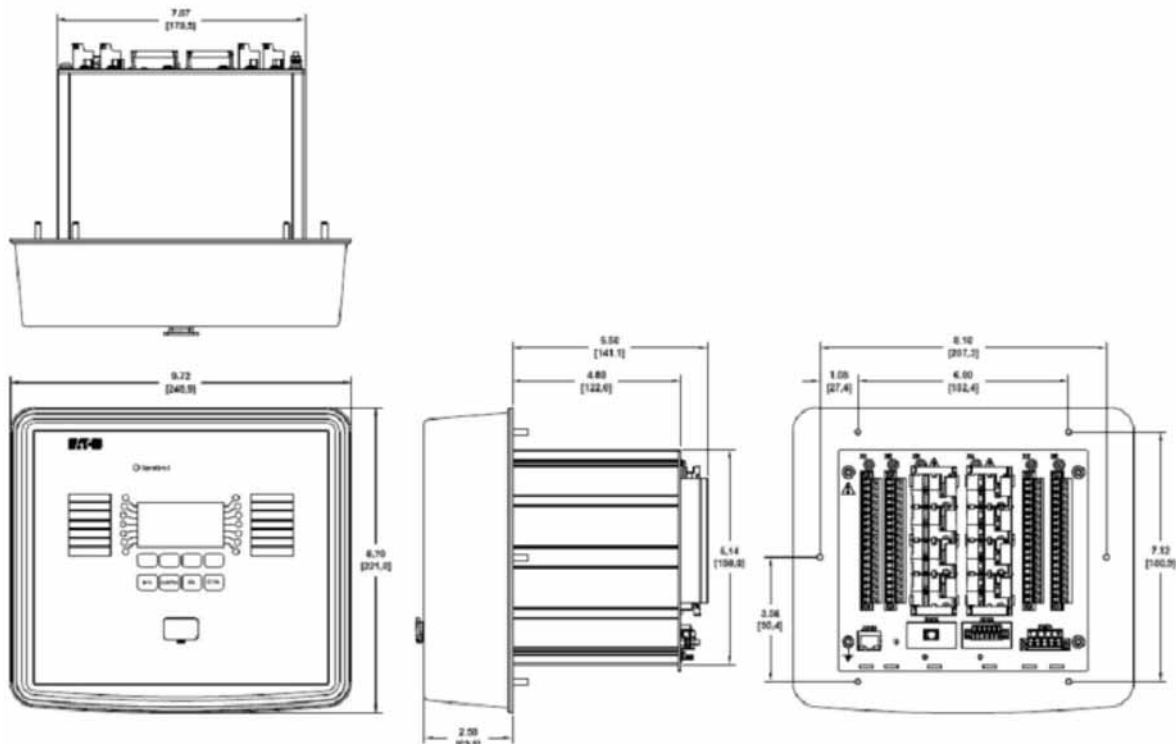

Approximate Dimensions in Inches (mm)

Standard Mount Front and Side Views

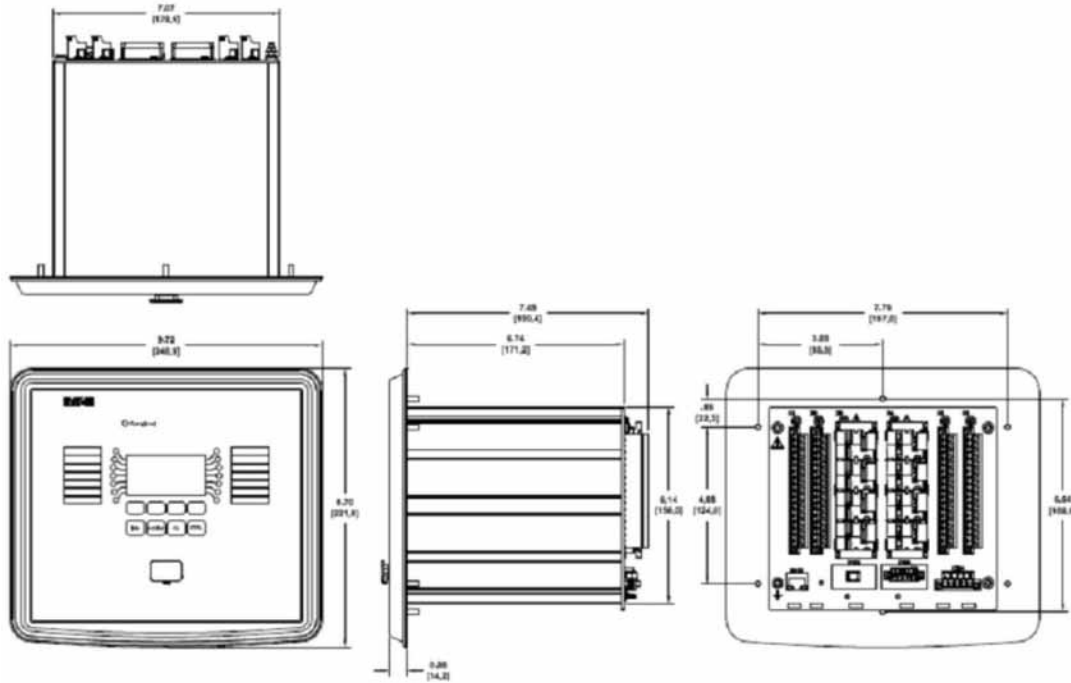

EMR-5000 Motor Protection Relay



Contents

<i>Description</i>	<i>Page</i>
Product Selection Guide	V3-T9-117
Digitrip 3000	V3-T9-123
EDR-3000 Feeder Protection	V3-T9-133
EDR-5000 Distribution Protection Relay	V3-T9-142
FP-5000 Feeder Protection	V3-T9-155
MP-3000 Motor Protection	V3-T9-163
MP-4000 Motor Protection	V3-T9-173
EMR-3000 Motor Protection Relay	V3-T9-179
EMR-4000 Motor Protection Relay	V3-T9-191
EMR-5000 Motor Protection Relay	V3-T9-216
ETR-4000 Transformer Protection Relay	V3-T9-228
ETR-5000 Transformer Protection Relay	V3-T9-228
EGR-5000 Generation Protection Relay	V3-T9-241
Ground Fault Relay	V3-T9-254
Universal RTD Module	V3-T9-257

EMR-5000 Motor Protection Relay

Product Description

Eaton’s EMR-5000 motor protection relay is a multifunctional microprocessor-based protective relay for the protection of any size motor at all voltage levels. It is most commonly applied on medium voltage or larger motors. The EMR-5000 relay is a current and voltage device with built-in differential protection that provides complete and reliable motor protection, monitoring, diagnostics, metering and starting control functions.

The EMR-5000 motor protection relay provides complete current, voltage, and frequency protection in a single compact case. The relay has eight current inputs rated for either 5 amperes or 1 ampere and four voltage inputs. Three of the voltage inputs are to be connected to the three-phase power voltage for voltage protection and for metering. They can be connected in wye-ground or open delta configuration.

The fourth voltage is for independent single-phase undervoltage/overvoltage protection. The unit is capable of 60 Hz or 50 Hz operation.

The maintenance mode password protected soft key, can be used for arc flash mitigation to change to an alternate settings group, set to have instantaneous elements only. The multiple setting groups can also be changed, via communications or a digital input. Flash memory is used for the programming and all settings are stored in nonvolatile memory.

An integral keypad and display is provided for direct user programming and retrieval of data without the need of a computer. Fourteen programmable LEDs provide quick indication of relay status.

A front port is provided for direct computer connection. An RS-485 and an Ethernet ports in the back are optional for local area networking using. Optional Modbus-RTU, Modbus-TCP or IEC-61850 protocols are supported.

The EMR-5000 motor protection relay includes programmable logic functions. Logic gates and timers may be defined and arranged for customized applications. With the programmable logic control functions you can simplify the complexity of your starting schemes by eliminating timers and auxiliary relays. Flash memory is used for the programming and all settings are stored in nonvolatile memory. The relay allows for four preprogrammed setting groups that can be activated through software, manually, or contact input.

The EMR-5000 motor protection relay has mass memory for data storage and a real-time clock with 1 ms time resolution. The relay will log 300 sequence of event records, 20 detailed trip logs, minimum/maximum values, load profiles, the 5 latest start profiles, motor trending, breaker/contactors wear information and waveform data.

The EMR-5000 has either eight programmable binary inputs, two analog inputs, two analog outputs, or 16 programmable binary inputs. It has 2NO and six Form C heavy-duty outputs and one form C signal alarm relay. The relay provides maximum user flexibility to configure the I/O. All inputs and outputs (except the healthy output) are user-programmable. The unit also counts with a test mode to force outputs and simulate currents, to facilitate the commissioning of the unit. It can be powered from 19 Vdc to 300 Vdc or 40 Vac to 250 Vac auxiliary power.

Application Description

Eaton’s EMR-5000 motor protection relay has been designed for maximum motor operation and protection. It permits running the motor close to its design limits while protecting it against excessive heating and damaging overload conditions. The EMR-5000 field proven protection algorithms were developed based on motor designs and operating parameters for optimum operation and protection while minimizing nuisance tripping. The EMR-5000 motor protection relay utilizes a patented protection algorithm and measurement technique based on proven positive and negative (unbalance) sequence current sampling and true RMS calculations.

Intel-I-Trip (I²t) Overload Protection

The EMR-5000 motor relay features the exclusive Eaton Intel-I-Trip intelligent overload protection system. Intel-I-Trip develops custom overload curves simply from motor nameplate data. Intel-I-Trip protects motors from potentially damaging overload and abnormal operating conditions. The Intel-I-Trip intelligent overload protection feature utilizes field proven measurement techniques and a patented motor thermal protection model. The EMR-5000 motor relay’s unique measurement technique samples the current waveforms 36 times per cycle, providing accurate measurements of the positive and negative sequence currents. The negative sequence current causes a greater heating effect on the rotor and has a greater impact on the thermal model in the relay. Intel-I-Trip utilizes these measurements in its motor model to safely protect the motor against the heating effects of these currents.

The motor thermal model is analogous to a bucket that is being filled and drained at the same time. The fill rate is dependent on the motor currents and the drain is based on motor design principles. The size of the bucket is equivalent to the thermal capacity associated with the mass of the motor. Intel-I-Trip integrates these rates and will issue a trip when the thermal capacity is filled.

Intel-I-Trip features adaptive trip characteristics that adjust the trip times based on measured motor temperature when RTDs are used.

Instantaneous Overcurrent

The EMR-5000 motor protection relay provides an instantaneous phase overcurrent function to trip the motor for high fault current levels and save the fuses. This function can be disabled and has an adjustable time delay on starting to avoid nuisance tripping on inrush.

Differential Protection

This protection function is mostly used to protect induction and synchronous motors against phase-to-phase faults. Differential protection may be considered the first line of protection for internal phase to phase or phase to ground faults. In the event of such faults, the quick response of the differential element may limit the damage that may have otherwise occurred to the motor. While this protection is recommended in all motors above 1500 hp, it can be used in smaller motors depending primarily in the importance and the cost of the motor.

Phase Unbalance Protection

Motor supply circuits are often fed through fuses and can be run with a single-phase fuse blown, referred to as single phasing the motor. The EMR-5000 motor protection relay measures the current and voltage unbalance and either can be used to alarm or trip the motor before damage occurs. The EMR-5000 has two voltage and two current unbalance elements. Pickup, start and run timers are provided for each element.

Ground Fault Protection

A separate measuring circuit is used to measure ground current. A ground CT is recommended for more sensitive protection against winding insulation breakdown to ground. The relay ground circuit can be connected residually from the three-phase CTs. The ground fault protection has pickup and time delay set points or can be disabled.

Jam Protection

The user-selectable Jam function protects motors that are running against a sudden mechanical jam or stall condition. The common application is on motors used on crushers, chippers, or conveyors. It detects an increase of motor current to a level above full load. Pickup, start, and run timers and a second element for alarm purposes are provided.

Underload/Underpower Protection

The user selectable underload/underpower function is used to detect the loss of load on the motor. Coupling failure is a common cause for loss of load. Whenever is possible, it is better to use underpower to detect loss of load. Three power elements and two underload elements are provided in the relay for tripping and alarm purposes. Pickup, start and run timers are provided for each element.

Frequency Protection

The frequency elements provide the ability to detect when the motor is operating at off-nominal frequencies that can do damage to the process or, to signal to upstream protections or controls to implement load shedding actions.

Power Factor Protection

This protection is used in synchronous motors applications to detect out-of-synchronism conditions.

Undervoltage/Overvoltage Protection

Use the voltage protective functions to detect abnormal system voltage conditions potentially hazardous to the motor.

Reduced Voltage Starting

The EMR-5000 motor protection relay provides a transition and incomplete sequence function for reduced voltage starting. The user can select to transition based on the current level and/or on time.

Antibackspin

The stop function is programmable from 2–20%. For certain applications, such as pumping a fluid up a pipe, the motor may be driven backward for a period of time after it stops. The EMR-5000 relay provides an antibackspin timer to prevent starting the motor while it is spinning in the reverse direction. The timer begins counting from the moment a stop is declared by the relay.

Start Control Timers

Motors typically have limits to the number of cold starts, starts per hour period, or time between starts that are permitted without damage. The EMR-5000 motor protection relay incorporates these timers to prevent starting the motor beyond its capabilities.

Load Shedding

The EMR-5000 motor protection relay provides a mechanical load shedding feature that can be used to control an upstream process. The load-shedding function closes a contact on an overload condition to control an upstream process from adding more load until the overload condition is gone.

Emergency Override

The EMR-5000 motor protection relay has a user-programmable feature that will let the operator reset the start inhibitor timers and thermal overload bucket. This function is intended for use in emergency conditions only, and it may result in motor damage or failure.

Long Acceleration Motors

Large motors with a high inertia may experience starting currents that exceed the locked rotor current and time. The EMR-5000 motor protection relay has logic and provisions for a zero speed switch input to differentiate between a stall and start condition. If the motor is spinning, then the relay will not trip on the normal locked rotor time allowing the motor to start.

Remote/Differential Trip

The digital inputs can be programmed to accept a contact input from a separate differential relay or other device to trip the motor. This provides local and remote target information and utilizes the trip contacts of the EMR-5000 motor protection relay. It will also record and log the motor information at the time of the trip.

Breaker Failure or Stuck Contactor

The EMR-5000 motor protection relay includes a breaker failure (50BF, 62BF) function that can be initiated from either an internal or external trip signal. This is an independent element that can be used to operate a lockout relay or trip an upstream breaker. The timer must be longer than the breaker operating time and the protective function reset times.

Flexible Phase Rotation

The EMR-5000 motor protection relay can be applied on either an A-B-C or A-C-B phase rotation. A user setting permits correct operation and indication of the actual system configuration.

Maintenance Mode

The Maintenance Mode can improve safety by providing a simple and reliable method to reduce fault clearing time and lower incident energy levels at energized panels. The Maintenance Mode allows the user to switch to more sensitive settings via a password protected soft key, communication or via a digital Input while maintenance work is being performed at an energized panel or device. The more sensitive settings provide greater security for maintenance personnel and helps reduce the possibility of injury.

Features, Benefits and Functions

Protection Features

- Motor differential protection (87M)
- Thermal protection (49/51)
 - Locked rotor protection (49S/51)
- Phase overcurrent elements:
 - Two instantaneous elements with timers (50P[1], 50P[2] and 50P[3])
 - Three inverse time overcurrent elements (51P[1], 51P[2] and 51P[3])
 - 11 standard curves
 - Instantaneous or time delay reset
- Ground overcurrent elements:
 - Two instantaneous measured elements with timers (50X[1] and 50X[2])
 - Two instantaneous calculated elements with timers (50R[1] and 50R[2])
 - Two inverse time overcurrent measured elements (51X[1] and 51X[2])
 - Two inverse time overcurrent calculated elements (51R[1] and 51R[2])
 - 11 standard curves
 - Instantaneous or time delay reset
- Jam or Stall protection (50J[1], 50J[2])
- Phase unbalance negative sequence overcurrent (46[1], 46[2])
- Underload protection (37[1], 37[2])
- Temperature protection with optional URTD (49/38)
- Stars per hour (66)
- Switch onto fault protection
- Phase voltage unbalance and sequence protection (47[1], 47[2])
- Main three-phase under/overvoltage (27M[1], 27M[2], 59M[1], 59M[2])
- Auxiliary single-phase under/overvoltage (27A[1], 27A[2], 59A[1], 59A[2])

- Six frequency elements that can be assigned to: over frequency, under frequency, rate of change, or vector surge (81[1], 81[2], 81[3], 81[4], 81[5], 81[6])
 - Apparent and displacement power factor (55A[1], 55A[2], 55D[1], 55D[2])
- Forward and reverse watts (32[1], 32[2], 32[3])
- Forward and reverse VARs (32V[1], 32V[2], 32V[3])
- Lockout protection (86)
- Breaker failure (50BF)
- Zone interlocking for bus protection (87B)

Metering Features

- Amperes: Positive, negative and zero sequence
- Volts: Positive, negative and zero sequence
- Differential current
- Volt-amperes and VA demand
- Watts and kW demand
- kWh (forward, reverse, net)
- VARs and kVAR demand
- kVARh (lead, leg and net)
- Power factor
- Frequency
- % THD V and I
- Magnitude THD V and I
- Minimum/maximum recording
- Trending (load profile over time)
- Minimum/maximum recording
- Temperature with remote URTD module

Monitoring Features

- Trip coil monitor
- Breaker wear primary and secondary (accumulated interrupted current)
- Oscillography (7200 cycles total)
- Trip Cause displays fault recorder data on HMI after fault event
- Fault data logs (up to 20 events)

- Sequence of events report (up to 300 events)
- Trending (load profile over time)
- Motor history
- Records the last 5 motor start profiles
- Motor start trending
- CT supervision
- VT supervision
- Clock (1 ms time stamping)

Diagnostic Features

- Broken rotor bar

Control Functions

- Transition for reduced voltage starts
- Incomplete sequence delay
- Permits numbers of cold starts
- Limits numbers of starts per hour
- Anti-backspin time delay
- Mechanical load shedding
- Zero speed switch for long acceleration motors
- Motor stop inputs
- Remote trip input
- Emergency override
- Breaker/Contactor open-close/stop-start
- Remote open-close (stop-start)
- Programmable I/O
- Programmable LEDs
- Programmable Logic
- Multiple setting groups

Communication Features

- Local HMI
- Password protected
- Addressable
- IRIG-B
- Local communication port:
 - RS-232
- Remote communication port:
 - RS-485
 - Ethernet port
- Protocols:
 - Modbus-RTU (Optional)
 - Modbus-TCP (Optional)
 - IEC-61850 (Optional)
- Configuration software

Diagnostic Features

Broken Rotor Bar

The EMR-5000 provides advanced motor diagnostics including a broken rotor bar detection function. The broken rotor bar detection is a condition maintenance function that continuously monitors the motor's health while in operation. The advanced Motor Current Signature Analysis (MCSA) continuously analyzes the motor current signature and based on preset algorithms will determine when a broken rotor bar is present in the motor.

The broken rotor bar function will provide early detection of any rotor problems and advise maintenance personnel of the impending issue allowing for predictive maintenance of the motor and prevention of catastrophic motor failures.

By providing early indication of potential rotor problems, serious system issues such as: reduced starting torque, overloads, torque and speed oscillation and bearing wear can be avoided. With the advanced broken rotor bar detection system, advanced warning of impending problems reduces catastrophic failures, maximizing motor life and system uptime.

Monitoring and Metering

Sequence of Events Records

The EMR-5000 protection relay records a maximum of 300 events associated with the relay. An event is classified as a change of state as detected by the relay. These include relay pickups, dropouts, trips, contact closure, alarms, setting changes and self-diagnostic failures. Each event is date and time stamped to a 1 ms resolution. The events are stored in a FIFO in chronological order.

Trip Log

The EMR-5000 protection relay will store a maximum of 20 trip records in a FIFO trip log. Each trip record will be date and time stamped to a 1 ms resolution. The trip log record will include information on the type of fault, protection elements that operated, fault location and currents and voltages at the time of the fault.

PowerPort-E

PowerPort-E is the software program used to configure off-line protection setting files for all E-Series relay models. PowerPort-E is also used for

viewing measured values of the relays in real-time, uploading/downloading setting files, and retrieving event log and waveform records.

Waveform Capture (Quality Manager)

The EMR-5000 relay provides oscillographic recording capabilities. The relay will record all measured signals along with the binary signals of pickup, trip, internal logic, and contact inputs. The EMR-5000 can record up to 7200 cycles of data. The number of records is proportional to the programmed size of each record; the maximum size per record is 600 cycles.

The waveform capture is initiated by up to 8 different triggers (i.e., trip/alarm events) or manually via communications or the HMI. PowerPort-E setting software is used to retrieve the records. Quality Manager is a separate software program downloaded with PowerPort-E used for analyzing the waveform and trending files retrieved from the relay.

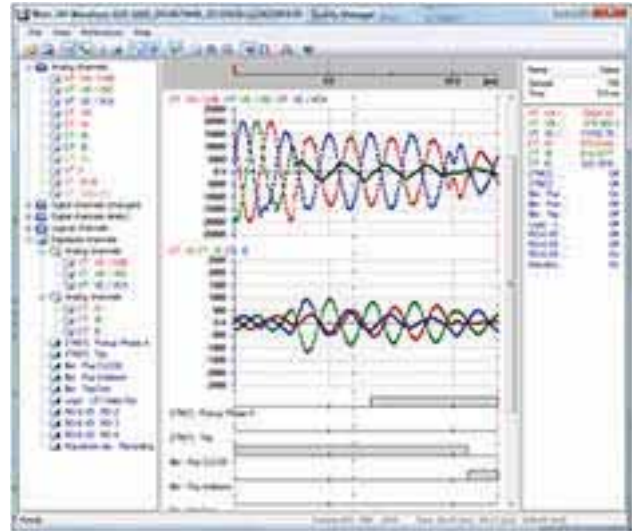

Waveform Capture (Quality Manager)

Integral User Interface

The front panel user interface has a 128 x 64 pixel LCD display with background illumination for wide angle viewing in all light conditions. Seven programmable LEDs provide quick and easy visual display of power on, mode of operation, alarm and trip indication. Soft keys are provided for operation mode selection, scrolling through data and settings. In addition, the relay settings and test functions are password protected.

Starting Profiles

The EMR-5000 records the average current versus time for the last five starting cycles. This information is available via the communications port through PowerPort-E.

Motor Statistics

For each motor start, the EMR-5000 stores a motor start report and add this data to the motor statistics buffer. With the motor statistics you can track motor start data for the past eighteen 30-day periods. For each 30-day interval, the relay records the following information:

- The date the interval began
- The total number of starts in the interval
- The averages of the following quantities:
 - Motor start time
 - Start % rotor thermal capacity used
 - Maximum start current

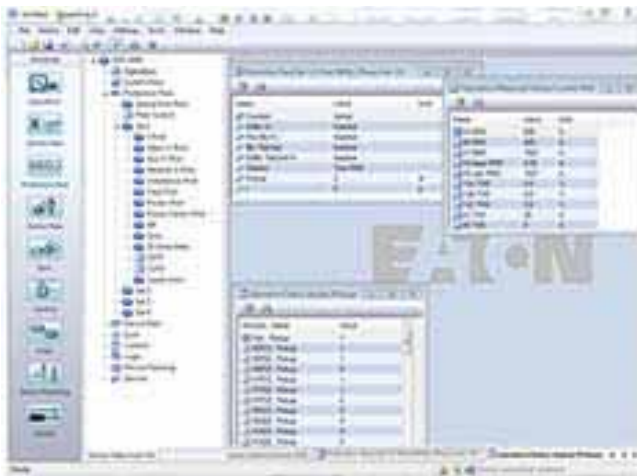

PowerPort-E

Load Profiling/Trending

The EMR-5000 relay automatically records selected quantities into non-volatile memory every 5, 10, 15, 30, or 60 minutes, depending on the trending report setting.

Programmable I/O

The EMR-5000 motor protection relay provides heavy-duty, trip-rated, 2 normally open and 1 Form C contacts. One isolated inputs can be used for monitoring the trip circuit. One Form C contact is dedicated to the relay failure alarm function and is operated in a normally energized (failsafe) mode. There are 4 eight user-configurable discrete inputs that accept a wet contact and can operate through a wide range of power. Each input and output is user-programmable for maximum application flexibility.

Programmable Logic

The EMR-5000 motor protection relay provides logic gates and timers that the user can customize for special or unique applications. Each gate can be assigned a logic function of either AND, OR, NAND or NOR. Each gate can have a maximum of four input signals and each input signal can be required to be a NOT. Input signals can be external inputs received via the binary inputs or internal values associated with the protection, alarm or metering set points. Each gate has a unique output assignment and designation that can be used as the input to another gate.

Standards and Certifications

Approvals

- UL listed file: E217753

Design Standards

- Generic Standard:
 - EN 61000-6-2
 - EN 61000-6-3
- Product Standard:
 - IEC 60255-6
 - EN 50178
 - UL 508 (Industrial Control Equipment)
 - CSA C22.2 No. 14-95 (Industrial Control Equipment)
 - ANSI C37.90



Catalog Number Selection

The catalog number identification chart defines the electrical characteristics and operation features included in the EMR-5000. For example, if the catalog number is EMR-5000-2A0BA, the device would have the following:

EMR-5000

(A)–Four digital inputs, four output relays, 1 4–20 mA analog output, URTD interface

(0)–5 A / 1 A phase and ground CTs, power supply range: 19–300 Vdc, 40–250 Vac

(B)–Modbus-RTU (RS-485)

(A)–Without conformal coating

(1)–Projection panel mount

EMR-5000 Eaton Motor Relay

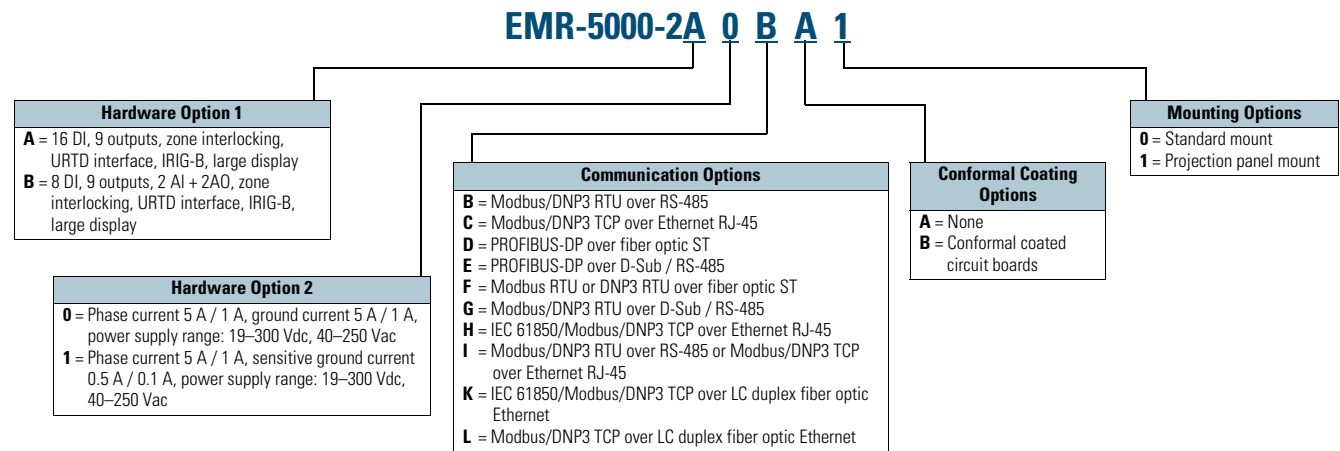

Technical Data and Specifications

Climatic Environmental Conditions

- Storage temperature: $-30\text{ }^{\circ}\text{C}$ to $+70\text{ }^{\circ}\text{C}$ ($-22\text{ }^{\circ}\text{F}$ to $158\text{ }^{\circ}\text{F}$)
- Operating temperature: $-20\text{ }^{\circ}\text{C}$ to $+60\text{ }^{\circ}\text{C}$ ($-4\text{ }^{\circ}\text{F}$ to $140\text{ }^{\circ}\text{F}$)
- Permissible humidity at ann. average: $<75\%$ rel. (on 56d up to 95% rel.)
- Permissible installation altitude:
 - $<2,000\text{ m}$ ($6,561.67\text{ ft}$) above sea level
 - If $4,000\text{ m}$ ($13,123.35\text{ ft}$) altitude applies, a changed classification of the operating and test voltages may be necessary

Degree of Protection EN 60529

- HMI front panel with seal: IP54
- Rear side terminals: IP20

Routine Test

- Insulation test acc. to IEC60255-5: All tests to be carried out against ground and other input and output circuits
- Aux. voltage supply, digital inputs, current measuring inputs, signal relay outputs: $2.5\text{ kV (eff.) / 50\text{ Hz}}$
- Voltage measuring inputs: $3.0\text{ kV (eff.) / 50\text{ Hz}}$
- All wire-bound communication interfaces: 1.5 kV DC

Housing

- Housing B2: height / width $183\text{ mm (7.205 in) / 212.7 mm (8.374 in)}$
- Housing depth (incl. terminals): 208 mm (8.189 in)
- Material, housing: aluminum extruded section
- Material, front panel: aluminum/foil front
- Mounting position: horizontal ($\pm 45^{\circ}$ around the X-axis must be permitted)
- Weight: approx. 4.2 kg (9.259 lb)

Current and Ground Current Measurement

Plug-in connector with integrated short-circuiter (Conventional current inputs)

Phase and ground current inputs:

- Nominal currents: 1 A / 5 A
- Max. measuring range:
 - Up to $40 \times I_n$ (phase currents)
 - Up to $25 \times I_n$ (ground current standard)
- Capacity: $4 \times I_n$ / continuously
- Overcurrent proof:
 - $30 \times I_n / 10\text{ s}$
 - $100 \times I_n / 1\text{ s}$
 - $250 \times I_n / 10\text{ ms}$ (1 half-wave)
- Power consumption:
 - Phase current inputs
 - At $I_n = 1\text{ A S} = 0.15\text{ MVA}$
 - At $I_n = 5\text{ A S} = 0.15\text{ MVA}$
 - Ground current inputs
 - At $I_n = 1\text{ A S} = 0.35\text{ MVA}$
 - At $I_n = 5\text{ A S} = 0.35\text{ MVA}$

Sensitive ground current inputs:

- Nominal currents: 1 A / 5 A with $50:0:025$ core balance CT
- Max. measuring range: up to $2.5 \times I_n$
- Capacity: $2 \times I_n$ / continuously
- Overcurrent proof:
 - $10 \times I_n / 10\text{ s}$
 - $25 \times I_n / 1\text{ s}$
 - $100 \times I_n / 10\text{ ms}$ (1 half-wave)
- Power consumption:
 - At $I_n = 1\text{ A S} = 0.35\text{ MVA}$
 - At $I_n = 5\text{ A S} = 0.35\text{ MVA}$
- Frequency range: $50\text{ Hz / 60 Hz} \pm 10\%$
- Terminals: screw-type terminals with integrated short-circuiters (contacts)
- Screws: M4, captive type acc. to VDEW

Connection cross sections:

- $1 \times$ or $2 \times 2.5\text{ mm}^2$ (2 x AWG 14) with wire end ferrule
- $1 \times$ or $2 \times 4.0\text{ mm}^2$ (2 x AWG 12) with ring cable sleeve or cable sleeve
- $1 \times$ or $2 \times 6\text{ mm}^2$ (2 x AWG 10) with ring cable sleeve or cable sleeve
- The current measuring board's terminal blocks may be used as with 2 (double) conductors AWG 10, 12, 14 otherwise with single conductors only

Voltage and Residual Voltage Measurement

- Nominal voltages: $60\text{--}520\text{ V}$ (can be configured)
- Max. measuring range: $2 \times$ nominal voltage or 800 V
- Continuous loading capacity: 800 Vac
- Power consumption:
 - at $V_n = 100\text{ V S} = 0.1\text{ MVA}$
 - at $V_n = 110\text{ V S} = 0.1\text{ MVA}$
 - at $V_n = 230\text{ V S} = 0.4\text{ MVA}$
 - at $V_n = 400\text{ V S} = 1.0\text{ MVA}$
- Nominal voltages: $60\text{--}520\text{ V}$ (can be configured)
- Frequency range: 50 Hz or $60\text{ Hz} \pm 10\%$
- Terminals: screw-type terminals

Frequency Measurement

- Nominal Frequencies: 50 Hz / 60 Hz

Voltage Supply

- Aux. voltage: $24\text{--}270\text{ Vdc / 48\text{--}230\text{ Vac (-20/+10\%)}$
- Buffer time in case of supply failure: $\geq 50\text{ ms}$ at minimal aux. voltage communication is permitted to be interrupted
- Max. permissible making current:
 - 18 A peak value for $<0.25\text{ ms}$
 - 12 A peak value for $<1\text{ ms}$

- The voltage supply must be protected by a fuse of:
 - 2.5 A time-lag miniature fuse $5 \times 20\text{ mm}$ (approx. $1/5\text{ in} \times 0.8\text{ in}$) according to IEC 60127
 - 3.5 A time-lag miniature fuse $6.3 \times 32\text{ mm}$ (approx. $1/4\text{ in} \times 1\text{ }1/4\text{ in}$) according to UL 248-14

Power Consumption

- Power supply range: $24\text{--}270\text{ Vdc}$
 - Power consumption in idle mode— 7 W
 - Maximum power consumption— 13 W
- Power supply range: $48\text{--}230\text{ Vac}$ (for frequencies of $50\text{--}60\text{ Hz}$)
 - Power consumption in idle mode— 7 VA
 - Maximum power consumption— 13 VA

Display

- Display type: LCD with LED background illumination
- Resolution graphics display: $128 \times 128\text{ pixel}$
- LED type: two colored, red/green
- Number of LEDs, housing B2: 15

Front Interface RS-232

- Baud rates: $115,200\text{ baud}$
- Handshake: RTS and CTS
- Connection: 9-pole D-Sub plug

Real-Time Clock

- Running reserve of the real-time clock: 1 year min

Digital Inputs

- Max. input voltage: 300 Vdc / 259 Vac
- Input current: <4 mA
- Reaction time: <20 ms
- Drop-out time:
 - Shorted inputs: <30 ms
 - Open inputs: <90 ms

Relay Output Contacts

- Continuous current: 5 A AC/DC
- Max. make current:
 - 25 A AC / 25 A DC for 4 s
 - 30 A / 230 Vac according to ANSI IEEE Std C37.90-2005
 - 30 A / 250 Vdc according to ANSI IEEE Std C37.90-2005
- Max. breaking current:
 - 5 A AC up to 240 Vac
 - 5 A DC up to 30 V (resistive)
- Continuous current: 5 A AC/DC
- Contact Type: Form C or normally open contact
- Terminals: screw-type terminals

Supervision Contact (SC)

- Continuous current: 5 A AC/DC
- Max. switch-on current: 15 A AC / 15 A DC for 4 s
- Max. breaking current:
 - 5 A AC up to 250 Vac
 - 5 A DC up to 30 Vdc (resistive)
 - 0.25 A at 250 Vdc (resistive)
- Max. switching voltage: 250 Vac / 250 Vdc
- Switching capacity: 1250 VA
- Contact type: Form C
- Terminals: screw-type terminals

Analog Outputs

The following technical data only apply to devices, which are equipped with analog outputs. Please refer to the order code of your device.

The mode of each output can be individually selected between current or voltage output. Shielded cable for the analog outputs is recommended. The terminals of the HF shield should be used, when connecting the shield to the ground on both sides of the cable is not possible. On one side of the cable the shield has to be directly connected to ground. In case of the use of unshielded twisted pair cables, the length must not exceed 10 m. All analog outputs have a common potential. Each output has an own common terminal.

- Current mode
 - Range: 0–20 mA
 - Max. load resistance: 1 k ohm
- Voltage mode range: 0–10 V maximum output current 20 mA
- Accuracy 0.5% of the nominal value 20 mA resp. 10 V
- Influence of temperature to accuracy: <1% (within the range of 0 °C to +60 °C (+32 °F to +140 °F))
- Test voltage of outputs (one group) against other electrical groups: 2.5 kV
- Test voltage of outputs (one group) against ground: 1.0 kV

Time Synchronization IIRIG-B00X

- Nominal Input Voltage: 5 V
- Connection: screw-type terminals (twisted pair)

Zone Interlocking

- Zone Out:
 - Output voltage (High): 4.75 to 5.25 Vdc
 - Output voltage (Low): 0.0 to +0.5 Vdc
- Zone In:
 - Nominal input voltage: +5 Vdc
 - Max. input voltage: +5.5 Vdc
 - Switching threshold ON: min. 4.0 Vdc
 - Switching threshold OFF: max. 1.5 Vdc
- Galvanic isolation: 2.5 kV AC (to ground and other IO)
- Connection: screw-type terminals (twisted pair)

RS-485

- Master/slave: slave
- Connection: 6 screw-clamping terminals RM 3.5 mm (138 MIL) (terminating resistors internal)

Fiber Optic

- Master/slave: slave
- Connection: ST-Plug

URTD-Interface

- Connection: versatile link

Boot Phase

After switching on the power supply, the protection will be available in approximately 19 seconds. After approximately 165 seconds, the boot phase is completed (HMI and communication initialized).

Wiring Diagrams

Typical AC Connections—Wye (or Delta) VTs, 5 A CTs, Ground Current Measured by 4th Zero Sequence CT, and 87 Motor Differential

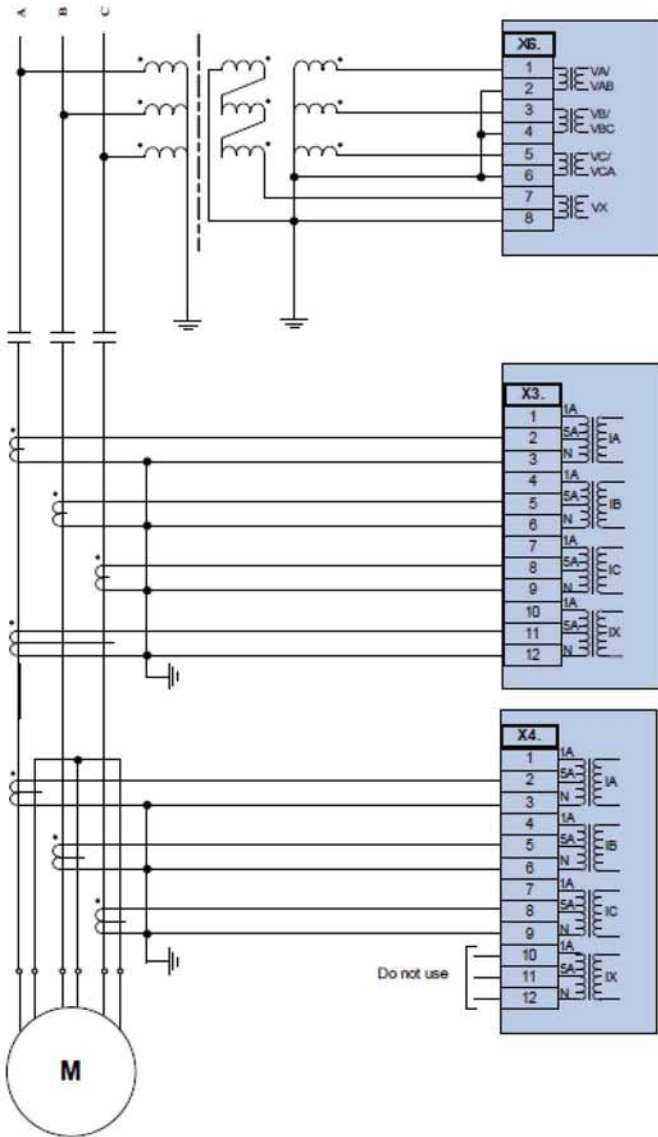

Typical One-Line Diagram

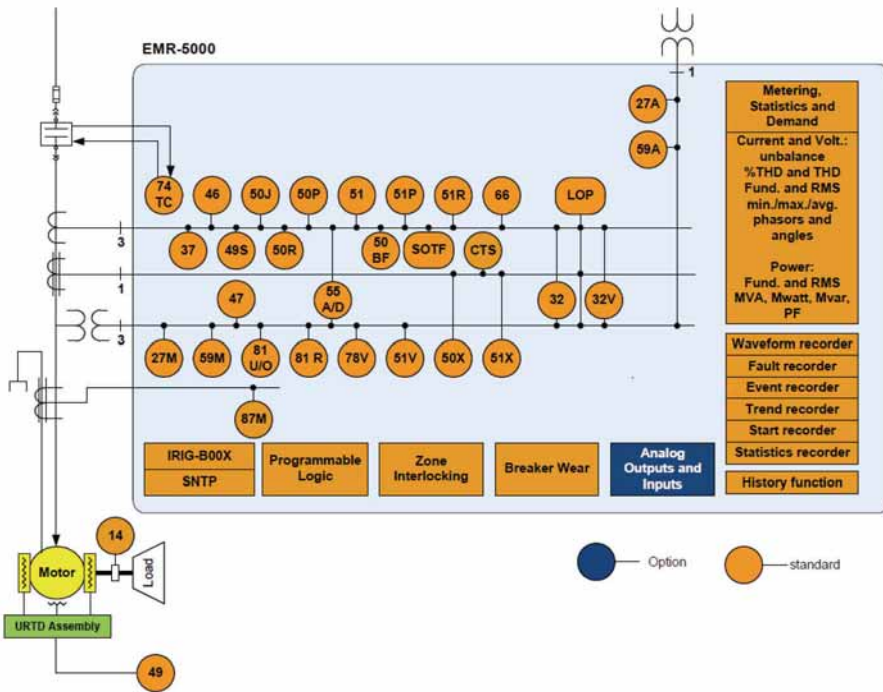

Typical Control Diagram

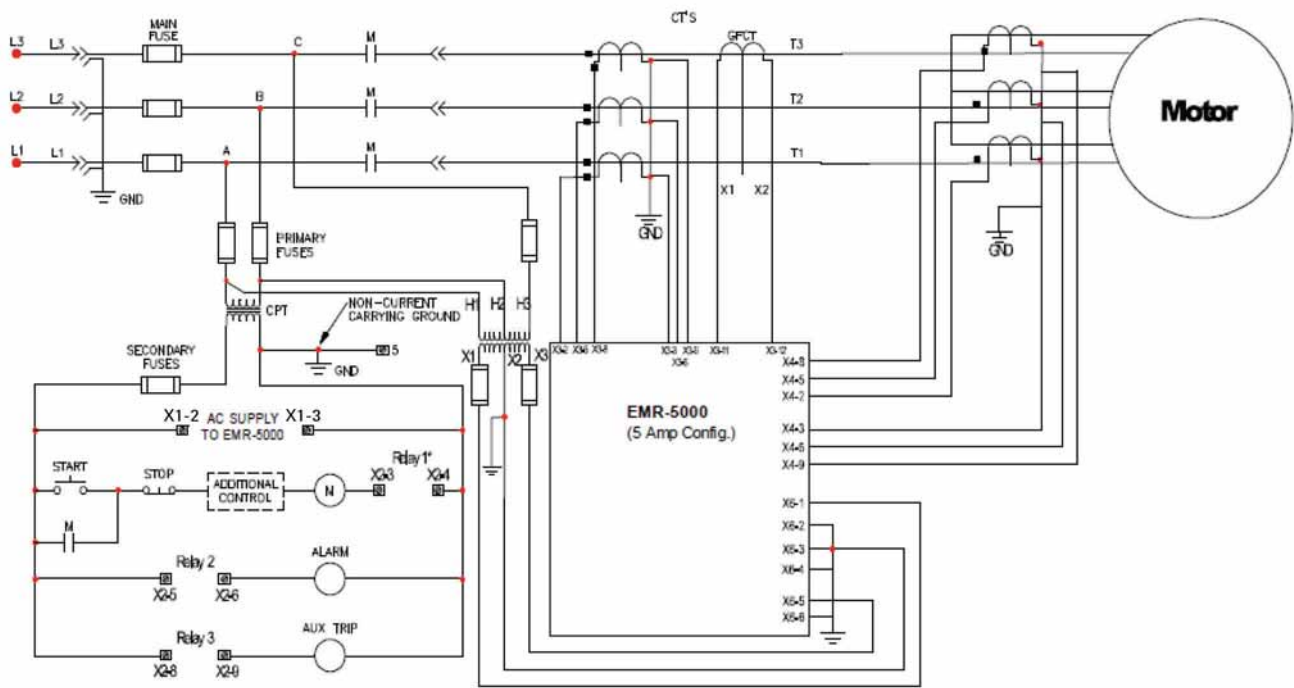

*THIS RELAY HAS TO BE OPEN TO ENSURE THAT PROTECTION IS ENABLED WHEN MOTOR IS STARTED.

Dimensions

Approximate Dimensions in Inches (mm)

Drilling Plan

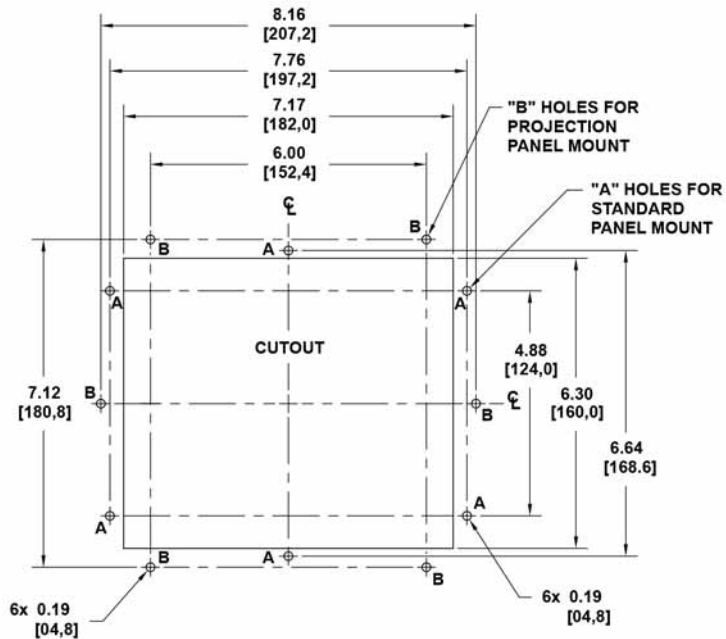

Projection Mount Front and Side Views

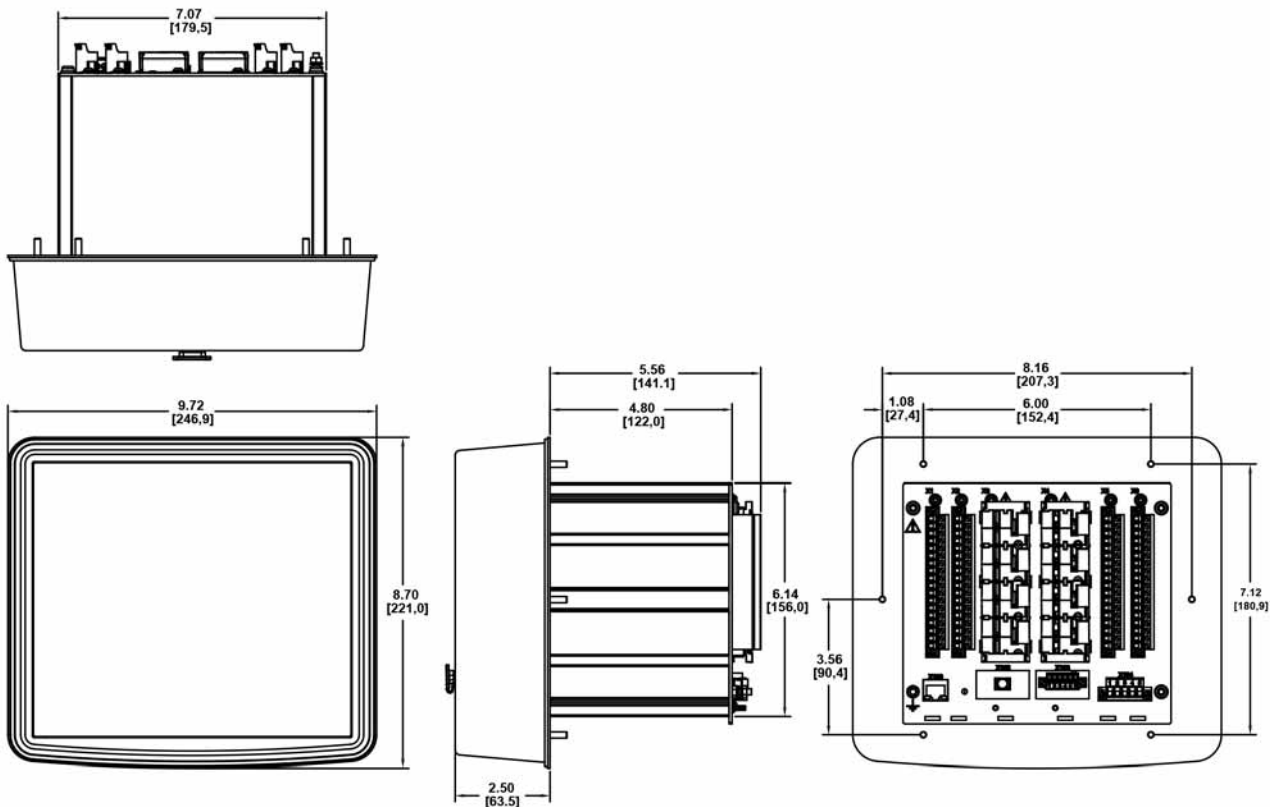

Approximate Dimensions in Inches (mm)

Standard Mount Front and Side Views

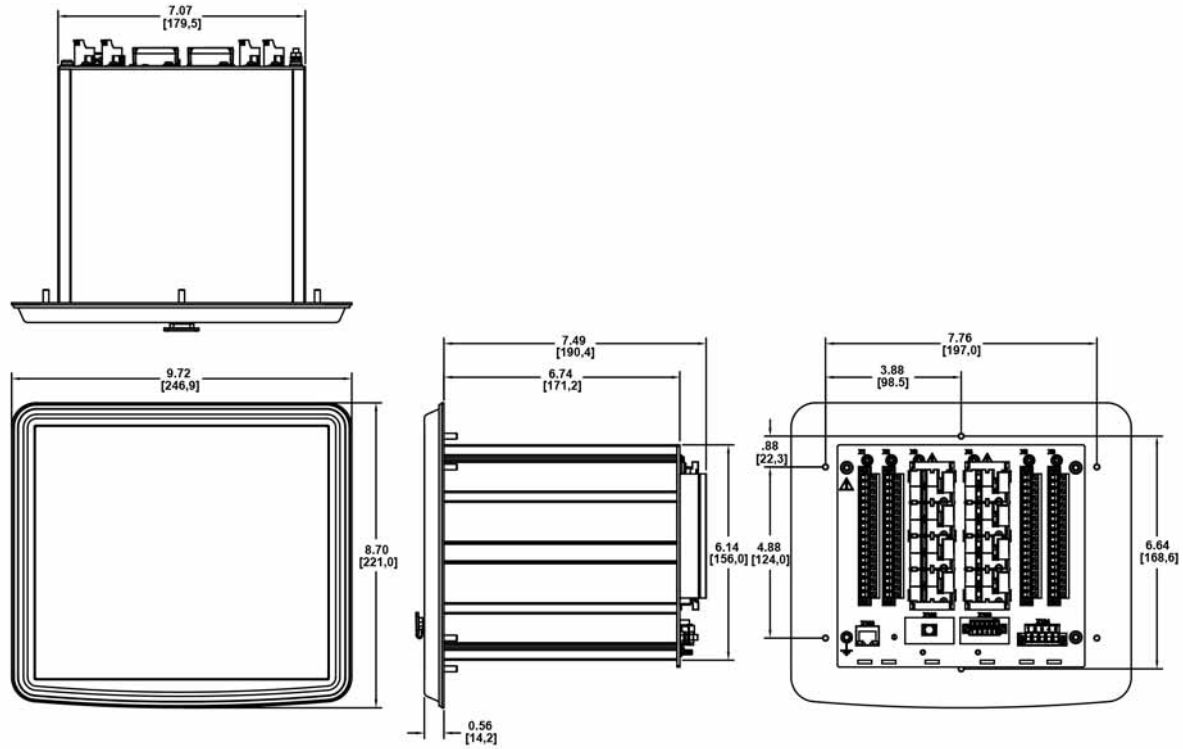

ETR-4000



Contents

<i>Description</i>	<i>Page</i>
Product Selection Guide	V3-T9-117
Digitrip 3000	V3-T9-123
EDR-3000 Feeder Protection	V3-T9-133
EDR-5000 Distribution Protection Relay	V3-T9-142
FP-5000 Feeder Protection	V3-T9-155
MP-3000 Motor Protection	V3-T9-163
MP-4000 Motor Protection	V3-T9-173
EMR-3000 Motor Protection Relay	V3-T9-179
EMR-4000 Motor Protection Relay	V3-T9-191
EMR-5000 Motor Protection Relay	V3-T9-204
ETR-4000 Transformer Protection Relay	V3-T9-228
ETR-5000 Transformer Protection Relay	V3-T9-241
EGR-5000 Generation Protection Relay	V3-T9-254
Ground Fault Relay	V3-T9-254
Universal RTD Module	V3-T9-257

ETR-4000 Transformer Protection Relay

Product Description

Eaton's ETR-4000 transformer protection relay is a multi-functional, microprocessor-based relay for two winding transformers of all voltage levels. The ETR-4000 provides phase and ground percentage restrained differential protection using a variable dual slope characteristic with phase, negative, residual and neutral overcurrent elements for backup protection. It can also be used to provide restrained differential protection to large motors and generators.

The ETR-4000 has eight current inputs rated for either 5 amperes or 1 ampere to monitor both sides of the transformers. The CTs can be connected in wye in both sides of the transformer; the relay automatically compensates for the connection of the transformer and CT mismatch errors.

The maintenance mode password protected soft key, can be used for arc flash mitigation to change to an alternate settings group, set to have instantaneous elements only.

An integral keypad and display is provided for direct user programming and retrieval of data without the need of a computer. Fourteen programmable LEDs provide quick indication of relay status.

A front port is provided for direct computer connection. An RS-485 communication port on the back is standard for local area networking using Modbus-RTU. An optional Ethernet port and protocols are available.

Flash memory is used for the programming and all settings are stored in nonvolatile memory. The relay allows for four preprogrammed setting groups that can be activated through software, the display or a contact input.

The ETR-4000 transformer protection relay has mass memory for data storage and a real-time clock with 1 ms time resolution. The relay will log 300 sequence of event records, 20 detailed trip logs, minimum/maximum values, load profiles, breaker wear information and oscillography data.

The ETR-4000 has eight programmable binary inputs, 4 normally opened and 4 Form C heavy-duty outputs and one Form C signal alarm relay. It can be powered from 19 Vdc to 300 Vdc or 40 Vac to 250 Vac auxiliary power.

Features, Benefits and Functions

- Flexible phase and ground differential protection for two winding transformers, large motors and generators
- Complete protection and control in a single compact case to reduce panel space, wiring and costs
- Integral test function reduces maintenance time and expense
- Zone selective interlocking improves coordination and tripping time, and saves money compared to a traditional bus differential scheme
- Reduce troubleshooting time and maintenance costs. Trip and event recording in non-volatile memory provides detailed information for analysis and system restoration. 6000 cycles of waveform capture aids in post fault analysis (viewable using PowerPort-E software)
- Minimum replacement time. Removable terminal blocks ideal for industrial environments
- Front RS-232 port and PowerPort-E software provides local computer access and user-friendly Windows-based interface for relay settings, configuration and data retrieval
- Breaker open/close from relay faceplate or remotely via communications
- Fast an easy troubleshooting, improved maintenance procedures and increased device security. Provides detailed traceability for system configuration changes
- Relays self-diagnostics and reporting improves uptime and troubleshooting
- Breaker trip circuit monitoring improves the reliability of the breaker operation

Features

Protection Features

- Dual-slope percentage restrained current differential with magnetizing inrush and overexcitation blocking (87R)
- Unrestrained current differential (87H)
- Restricted ground fault/ Ground Differential (87GD)
- Phase overcurrent (elements can be assigned to either side of the transformer):
 - Four instantaneous elements with timers (50P[1], 50P[2], 50P[3] and 50P[4])
 - Four inverse time overcurrent elements (51P[1], 51P[2], 51P[3] and 51P[4])
 - 11 standard curves
 - Inrush Blocking
 - Instantaneous or time delay reset
- Negative sequence phase overcurrent (elements can be assigned to either side of the transformer):
 - Two inverse time overcurrent elements (51Q[1] and 51Q[2])
 - 11 standard curves
 - Instantaneous or time delay reset
- Ground overcurrent (elements can be assigned to either side of the transformer):
 - Two instantaneous measured elements with timers (50X[1] and 50X[2])
 - Two instantaneous calculated elements with timers (50R[1] and 50R[2])
 - Two inverse time overcurrent measured elements (51X[1] and 51X[2])
 - Two inverse time overcurrent calculated elements (51R[1] and 51R[2])
 - 11 standard curves
 - Instantaneous or time delay reset

- Two breaker failure elements (50BF[1] and 50BF[2])
- Phase transformer overload protection (49)
- Switch onto fault protection
- Cold load pickup
- Zone interlocking for bus protection (87B)

Metering Features

- Amperes: positive, negative and zero sequence
- Ampere demand
- Current phase angles
- % THD I
- Magnitude THD I
- Minimum/maximum recording
- Trending
- RTD Temperatures with remote URTD

Monitoring Features

- Trip coil monitor for both primary and secondary breakers
- Breaker wear primary and secondary (accumulated interrupted current)
- Oscillography (7200 cycles total)
- Fault data logs (up to 20 events)
- Sequence of events report (up to 300 events)
- Clock (1 ms time stamping)
- Trip Cause displays fault recorder data on HMI after fault event

Control Functions

- Breaker open/close both breakers
- Remote open/close
- Programmable I/O
- Programmable LEDs
- Multiple setting groups
- Cold load pickup
- CT supervision

Communication Features

- Local HMI
- Password protected
- Addressable
- IRIG-B
- Local communication port

- Remote communication port:
 - RS-232
 - RS-485
- Protocols:
 - Modbus-RTU
 - Modbus-TCP (Optional)
- Configuration software

Protection and Control Functions

Eaton’s ETR-4000 transformer protection relay has been designed for maximum user flexibility and simplicity. The ETR-4000 is suitable for application on small, medium and large two winding power transformers.

Multiple current inputs are used to provide primary protection, control and back-up protection of transformers, including current differential, restricted ground differential and overcurrent protection.

Dual-Slope Percent Differential Protection

The primary protective element for transformer protection is the percent differential element, which compares the current entering the primary and leaving the secondary of the transformer. The ETR-4000 has built in compensation for the turns-ratio and the phase shift of the transformer, so it’s not necessary to compensate for the transformer connection by the connection of the CTs.

The current differential element looks at the vector difference between the current entering and leaving the zone of protection. If the difference exceeds a pre-determined amount, the element will operate.

The operating characteristic of the percent differential element is a dual-slope characteristic to accommodate for CT saturation and CT errors.

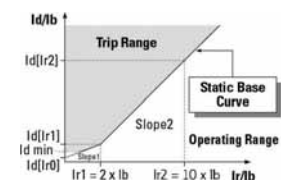

Dual-Slope Operating Characteristic

Harmonic Restraints

There are certain conditions like energizing one side of the transformer with the other side de-energized (inrush currents) or the paralleling of two transformers (sympathetic currents) that can create false differential currents. These differential currents if not recognized can cause a false trip; in the case of inrush conditions or sympathetic currents the differential current is characterized by a heavy content of 2nd and 4th harmonic currents. The percentage differential element is desensitized either permanently (stationary conditions) or temporarily (transient conditions), whenever the 2nd or 4th harmonic exceed the value programmed into the relay.

Another condition that can create a false differential current is a sudden change of voltage or frequency, that can put the transformer in an overexcitation state. In this case there is high content of 5th harmonic currents. The percentage differential element is also desensitized when the 5th harmonic content exceeds a predefined value.

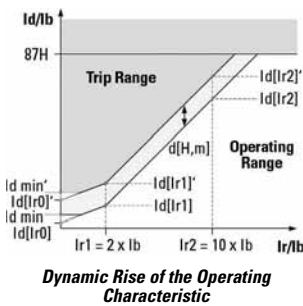

Unrestrained Differential

An unrestrained differential element is provided for fast tripping on heavy internal faults to limit catastrophic damage to the transformer and minimize risks to the remainder of the power system.

Restricted Ground Fault

Ground differential protection is applied to transformers having impedance grounded wye windings. It is intended to provide sensitive ground fault detection for low magnitude fault currents, which would not be detected by the main percent differential element.

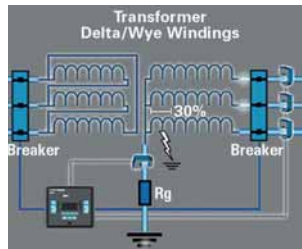

Restricted Ground Fault

Overcurrent Elements

The ETR-4000 can be used to provide backup for transformer and adjacent power system equipment. Instantaneous overcurrent elements can be used for fast clearing of severe internal or external (through) faults. Time overcurrent protection elements per winding allow coordinating with the adjacent protection zones and acting as a backup protection. There are 11 user-selectable inverse-time overcurrent curve characteristics. The user can select from the ANSI, IEC or thermal curve families and can select instantaneous or time delay reset characteristics.

Negative Sequence Overcurrent

Since this element does not respond to balanced load or three-phase faults, the negative-sequence overcurrent element may provide the desired overcurrent protection. This is particularly applicable to delta-wye grounded transformers where only 58% of the secondary p.u. phase-to-ground fault current appears in any one primary phase conductor. Backup protection can be particularly difficult when the wye is impedance grounded. A negative-sequence element can be used in the primary supply to the transformer and set as sensitively as required to protect for secondary phase-to-ground or phase-to-phase faults. This element should be set to coordinate with the low-side phase and ground relays for phase-to-ground and phase-to-phase faults. The negative sequence element must also be set higher than the negative-sequence current due to unbalanced loads.

Breaker Failure

The ETR-4000 transformer protection relay includes two breaker failure (50BF, 62BF) elements that can be initiated from either an internal or external trip signal. These are independent elements that can be used to operate a lockout relay or trip an upstream breaker. The timer must be longer than the breaker operating time and the protective function reset times.

Maintenance Mode

The Maintenance Mode can improve safety by providing a simple and reliable method to reduce fault clearing time and lower incident energy levels at energized panels. The Maintenance Mode allows the user to switch to more sensitive settings via a password protected soft key, communications or via a digital input while maintenance work is being performed at an energized panel or device. The more sensitive settings provide greater security for maintenance personnel and helps reduce the possibility of injury.

Monitoring and Metering

Sequence of Events Records

The ETR-4000 protection relay records a maximum of 300 events associated with the relay. An event is classified as a change of state as detected by the relay. These include relay pickups, dropouts, trips, contact closure, alarms, setting changes and self-diagnostic failures. Each event is date and time stamped to a 1 ms resolution. The events are stored in a FIFO in chronological order.

Trip Log

The ETR-4000 protection relay will store a maximum of 20 trip records in a FIFO trip log. Each trip record will be date and time stamped to a 1 ms resolution. The trip log record will include information on the type of fault, protection elements that operated, fault location and currents at the time of the fault.

Waveform Capture

The ETR-4000 transformer protection relay provides oscillography-recording capabilities. The relay will record all measured signals along with the binary signals of pickup, trip, logic and contact closures. The ETR-4000 relay can record up to 6000 cycles of data. The number of records is proportional to the size of each record; the maximum size per record is 600 cycles. The waveform capture is initiated by up to 8 different triggers; it can also be generated manually through the display or via communications.

Integral User Interface

The front panel user interface has a 128 x 64 pixel LCD display with background illumination for wide angle viewing in all light conditions. Fourteen programmable LEDs provide quick and easy visual display of power on, mode of operation, alarm and trip indication. Soft keys are provided for operation mode selection, scrolling through data and settings. In addition, the relay settings and test functions are password protected.

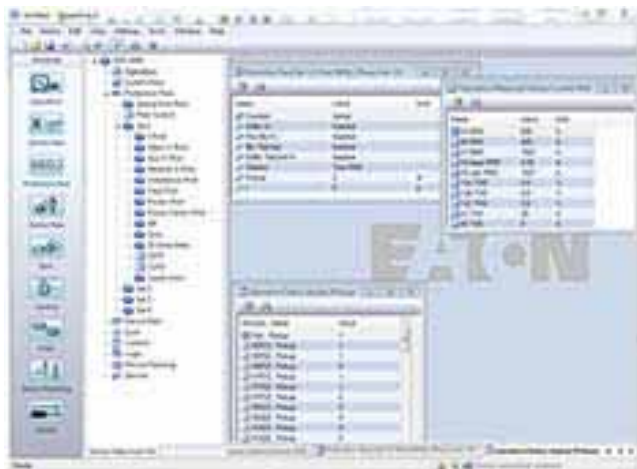

Programmable I/O

The ETR-4000 transformer protection relay provides heavy-duty, trip-rated, 4 normally open and 4 Form C contacts. Two isolated inputs can be used for monitoring the trip circuits. One Form C contact is dedicated to the relay failure alarm function and is operated in a normally energized (fail-safe) mode. There are eight user-configurable discrete inputs that accept a wet contact and can operate through a wide range of power. Each input and output is user-programmable for maximum application flexibility.

Communication Software

PowerPort-E

PowerPort-E is the software program used to configure off-line protection setting files for all E-Series relay models. PowerPort-E is also used for viewing measured values of the relays in real-time, uploading/downloading setting files, and retrieving event log and waveform records.

Waveform Capture (Quality Manager)

The ETR-4000 relay provides oscillographic recording capabilities. The relay will record all measured signals along with the binary signals of pickup, trip, internal logic, and contact inputs. The ETR-4000 can record up to 7200 cycles of data. The number of records is proportional to the programmed size of each record; the maximum size per

record is 600 cycles. The waveform capture is initiated by up to 8 different triggers (i.e., trip/alarm events) or manually via communications or the HMI. PowerPort-E setting software is used to retrieve the records. Quality Manager is a separate software program downloaded with PowerPort-E used for analyzing the waveform and trending files retrieved from the relay.

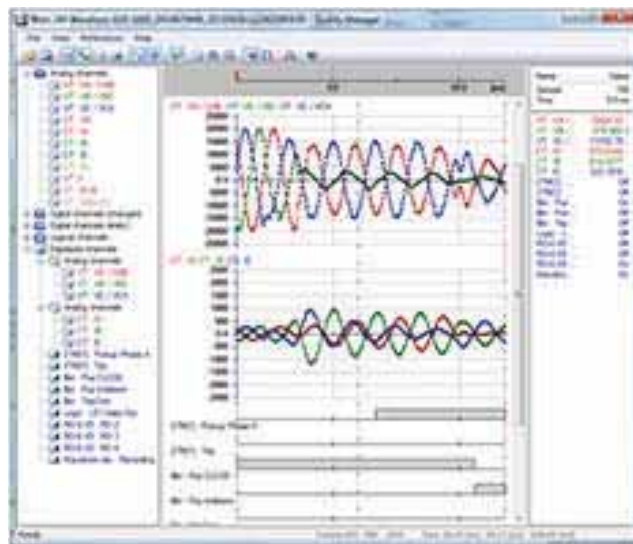

Standards and Certifications

Design Standards

- Generic Standard:
 - EN 61000-6-2
 - EN 61000-6-3
- Product Standard:
 - IEC 60255-6
 - EN 50178
 - UL 508 (Industrial Control Equipment)
 - CSA C22.2 No. 14-95 (Industrial Control Equipment)
 - ANSI C37.90
- UL listed file: E217753



Catalog Number Selection

The catalog number identification chart defines the electrical characteristics and operation features included in the ETR-4000. For example, if the catalog number is ETR-4000-2A0BA1, the device would have the following:

ETR-4000

(A)–8 Digital Inputs, 9 Output Relays

(0)–5 A / 1 A phase and ground CTs, Power Supply Range: 19-300 Vdc, 40–250 Vac

(B)–Modbus-RTU (RS-485)

(A)–Without Conformal Coating

(1)–Projection Panel Mount

ETR-4000 Eaton Transformer Protection Relay

ETR-4000-2A 0 B A 1

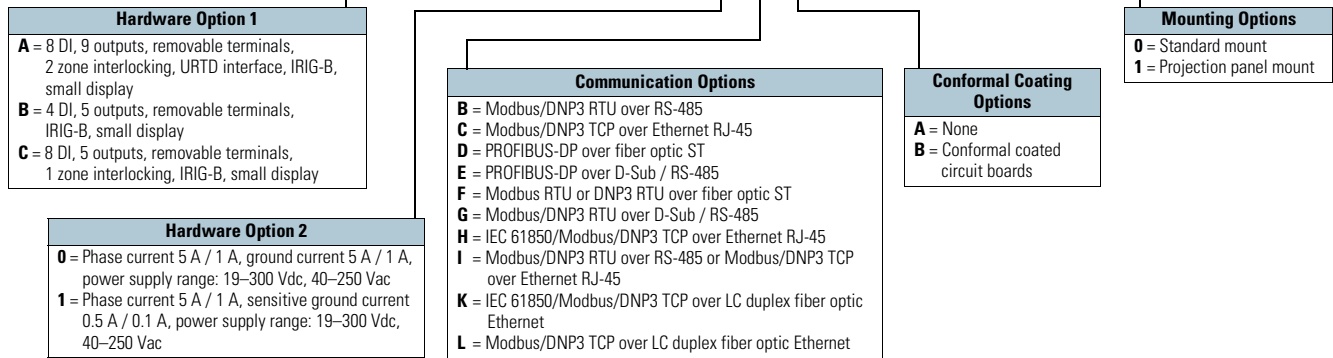

Technical Data and Specifications

Climatic Environmental Conditions

- Storage temperature: –22 °F to +158 °F (–30 °C to +70 °C)
- Operating temperature: –40 °F to +140 °F (–40 °C to +60 °C)
- Permissible humidity at ann. average: <75% rel. (on 56d up to 95% rel.)
- Permissible installation altitude:
 - 6,561.67 ft (<2000 m) above sea level
 - If 13,123.35 ft (4000 m) altitude applies, a changed classification of the operating and test voltages may be necessary

Degree of Protection EN 60529

- HMI front panel with seal: IP54
- Rear side terminals: IP30

Note

⊙ Display will stop working at –20 °C.

Routine Test

- Insulation test according to IEC 60255-5: All tests to be carried out against ground and other input and output circuits
- Aux. voltage supply, digital inputs: 2.5 kV (eff.)/50 Hz
- Current measuring inputs, signal relay outputs: 2.5 kV (eff.)/50 Hz
- Voltage measuring inputs: 3.0 kV (eff.)/50 Hz
- All wire-bound communication interfaces: 1.5 kV DC

Housing

- Material, housing: Aluminum extruded section
- Material, front panel: Aluminum/foil front
- Mounting position: Horizontal (±45° around the X-axis must be permitted)

Plug-in Connector with Integrated Short-Circuiter (Conventional Current Inputs)

- Nominal current: 1 A and 5 A
- Continuous loading capacity: 4 x I_n/continuously
- Overcurrent withstand:
 - 30 x I_n/10 s
 - 100 x I_n/1 s
 - 250 x I_n/10 ms (1 half-wave)
- Screws: M4, captive type acc. to VDEW
- Connection cross sections:
 - 2 x AWG 14 (1 x or 2 x 2.5 mm²) with wire end ferrule
 - 2 x AWG 12 (1 x or 2 x 4.0 mm²) with ring cable sleeve or cable sleeve
 - 2 x AWG 10 (1 x or 2 x 6 mm²) with ring cable sleeve or cable sleeve

Control Power Supply

- Aux. voltage: 24–270 Vdc/48–230 Vac (–20/+10%)
- Buffer time in case of supply failure: ≥50 ms at minimal aux. voltage interrupted communication is permitted
- Maximum permissible making current:
 - 18 A peak value for <0.25 ms
 - 12 A peak value for <1 ms
- The voltage supply must be protected by a fuse of:
 - 2.5 A time-lag miniature fuse approx. 0.2 x 0.8 in (5 x 20 mm) according to IEC 60127
 - 3.5 A time-lag miniature fuse approx. 0.25 x 1.25 in (6.3 x 32 mm) according to UL 248-14

Power Consumption

- Power supply range: 19–300 Vdc
 - Power consumption in idle mode—7 W
 - Maximum power consumption—13 W
- Power supply range: 40–250 Vac (for frequencies of 40–70 Hz)
 - Power consumption in idle mode—7 W
 - Maximum power consumption—13 W

Real-Time Clock

- Running reserve of the real-time clock: 1 year minimum

Display

- Display type: LCD with LED background illumination
- Resolution graphics display: 128 x 64 pixel
- LED type: Two colored—red/green
- Number of LEDs, housing B2: 15

Digital Inputs

- Maximum input voltage: 300 Vdc/270 Vac
- Input current: <4 mA
- Reaction time: <20 ms
- Fallback time: <30 ms

(Safe state of the digital inputs)

- 4 switching thresholds: $U_n = 24 \text{ Vdc}, 48 \text{ Vdc}, 60 \text{ Vdc}, 110 \text{ Vac/Vdc}, 230 \text{ Vac/Vdc}$
 - $U_n = 24 \text{ Vdc}$
 - Switching threshold 1 ON: Min. 19.2 Vdc
 - Switching threshold 1 OFF: Max. 9.6 Vdc
 - $U_n = 48\text{--}60 \text{ Vdc}$
 - Switching threshold 2 ON: Min. 42.6 Vdc
 - Switching threshold 2 OFF: Max. 21.3 Vdc

- $U_n = 110/120 \text{ Vac/Vdc}$
 - Switching threshold 3 ON: Min. 88.0 Vdc/88.0 Vac
 - Switching threshold 3 OFF: Max. 44.0 Vdc/44.0 Vac
- $U_n = 230/240 \text{ Vac/Vdc}$
 - Switching threshold 4 ON: Min. 184 Vdc/184 Vac
 - Switching threshold 4 OFF: Max. 92 Vdc/92 Vac
- Terminals: screw-type terminal

Current and Ground Current Measurement

- Nominal currents: 1 A / 5 A
- Max. measuring range:
 - Up to $40 \times I_n$ (phase currents)
 - Up to $25 \times I_n$ (ground current standard)
 - Up to $2.5 \times I_n$ (ground current sensitive)
- Continuous loading capacity: $4 \times I_n$ continuously
- Overcurrent proof:
 - $30 \times I_n/10 \text{ s}$
 - $100 \times I_n/1 \text{ s}$
 - $250 \times I_n/10 \text{ ms}$ (1 half-wave)
- Power consumption:
 - Phase current inputs
 - At $I_n = 1 \text{ A}$ $S = 0.15 \text{ MVA}$
 - At $I_n = 5 \text{ A}$ $S = 0.15 \text{ MVA}$
 - Ground current input
 - At $I_n = 1 \text{ A}$ $S = 0.35 \text{ MVA}$
 - At $I_n = 5 \text{ A}$ $S = 0.35 \text{ MVA}$
- Frequency range: 50 Hz/60 Hz $\pm 10\%$
- Terminals: Screw-type terminals with integrated short-circuiters (contacts)

Relay Outputs

- Continuous current: 5 A AC/DC
- Maximum make current:
 - 25 A AC/25 A DC up to 30 V for 4s
 - 30 A/230 Vac according to ANSI IEEE Std. C37.90-2005
 - 30 A/250 Vdc according to ANSI IEEE Std. C37.90-2005
- Maximum breaking current:
 - 5 A AC up to 125 Vac
 - 5 A DC up to 30 V (resistive)
 - 0.3 A DC at 300 V
- Maximum switching voltage: 250 Vac/250 Vdc
- Switching capacity: 1250 VA
- Contact type: changeover contact or normally open contact
- Terminals: screw-type terminals

Supervision Contact (SC)

- Continuous current: 5 A at 120/240 Vac or 30 Vdc
- Maximum switch-on current: 15 A at 120/240 Vac or 30 Vdc (max. 4 s)
- Maximum breaking current:
 - 5 A at 120/240 Vac or 30 Vdc
 - 0.4 A at 125 Vdc
- Contact type: 1 changeover contact
- Terminals: screw-type terminals

Time Synchronization IRIG

- Nominal input voltage: 5 V
- Connection: Screw-type terminals (twisted pair)

Front Interface RS-232

- Baud rates: 115,200 baud
- Handshake: RTS and CTS
- Connection: 9-pole D-Sub plug

RS-485

- Master/slave: slave
- Connection: 6 screw-clamping terminals RM 138 MIL (3.5 mm) (terminating resistors internal)

Zone Interlocking

- Nominal input level: 5 V
- Nominal output level: 5 V
- Connection: Screw-type terminals (twisted pair)

Standards

High Voltage Tests (IEC 60255-6)

- High frequency interference test:
 - IEC 60255-22-1 Class 3
 - Within one circuit—1 kV/2 s
 - Circuit to ground—2.5 kV/2 s
 - Circuit to circuit—2.5 kV/2 s
- Insulation voltage test:
 - IEC 60255-5, EN 50178
 - All circuits to other circuits and exposed conductive parts: 2.5 kV (eff.)/50 Hz, 1 min.
 - Except interfaces: 1.5 kV DC, 1 min.
 - Voltage measuring input: 3 kV (eff.)/50 Hz, 1 min.
- Impulse voltage test:
 - IEC 60255-5: 5 kV/0.5J, 1.2/50 μs

EMC Immunity Tests

- Fast transient disturbance immunity test (burst):
 - IEC 60255-22-4: Power supply, mains inputs— ± 4 kV, 2.5 kHz
 - IEC 61000-4-4 Class 4: Other inputs and outputs— ± 2 kV, 5 kHz (coupling network)
 - ANSI C37.90.1: ± 4 kV, 2.5 kHz (coupling clamp)
- Surge Immunity Test:
 - IEC 61000-4-5 Class 4
 - Within one circuit—2 kV
 - Circuit to ground—4 kV
- Electrical discharge immunity test:
 - IEC 60255-22-2: Air discharge—8 kV
 - IEC 61000-4-2 Class 3: Contact discharge—6 kV
- Radiated radio frequency electromagnetic field immunity test
 - IEC 61000-4-3: 26 MHz – 80 MHz—10 V/m
 - Class X: 80 MHz–1 GHz—35 V/m
 - ANSI C37.90.2: 1 GHz–3 GHz—10 V/m
- Immunity to conducted disturbances induced by radio frequency fields:
 - IEC 61000-4-6 Class 3: 10 V
- Power frequency magnetic field immunity test:
 - IEC 61000-4-8: Continues—30 A/m
 - Class 4: 3 sec—300 A/m

EMC Emission Tests

- Radio interference suppression test:
 - IEC/CISPR11—Limit value class B
- Radio interference radiation test:
 - IEC/CISPR11—Limit value class B

Environmental Tests

- Classification
- IEC 60068-1: Climatic—0/055/56
 - IEC 60721-3-1:
 - Classification of ambient conditions (storage)—1K5/1B1/1C1L/1S1/1M2 but min. -13 °F (-25 °C)
 - IEC 60721-3-2: Classification of ambient conditions (transportation)—2K3/2B1/2C1/2S1/2M2
 - IEC 60721-3-3: Classification of ambient conditions (Stationary use at weather protected locations)—3K6/3B1/3C1/3S1/3M2 but min. 32 °F (0 °C) and 3K8H for 2 h

Test ad: Cold

- IEC 60068-2-1:
 - Temperature— -4 °F (-20 °C)
 - Test duration—16 h

Test Bd: Dry heat

- IEC 60068-2-2:
 - Temperature—131 °F (55 °C)
 - Relative humidity— $< 50\%$
 - Test duration—72 h

Test cab: Damp heat (steady state)

- IEC 60068-2-78:
 - Temperature—104 °F (40 °C)
 - Relative humidity—93%
 - Test duration—56d

Test Db: Damp heat (cyclic)

- IEC 60068-2-30:
 - Temperature—131 °F (55 °C)
 - Relative humidity—95%
 - Cycles (12 + 12-hour)—2

Mechanical Tests**Test Fc: Vibration response test**

- IEC 60068-2-6, IEC 60255-21-1, Class 1:
 - Displacement: (10 Hz–59 Hz)—0.0014 in (0.035 mm)
 - Acceleration: (59 Hz–150 Hz)—0.5 gn
 - Number of cycles in each axis: 1

Test Fc: Vibration endurance test

- IEC 60068-2-6, IEC 60255-21-1, Class:
 - Acceleration: (10 Hz–150 Hz)—1.0 gn
 - Number of cycles in each axis: 20

Test Ea: Shock test

- IEC 60068-2-27, IEC 60255-21-2, Class 1
 - Shock response test: 5 gn, 11 ms, 3 impulses in each direction
 - Shock resistance test: 15 gn, 11 ms, 3 impulses in each direction

Test Eb: Shock endurance test

- IEC 60068-2-29, IEC 60255-21-2, Class 1
 - Shock endurance test: 10 gn, 16 ms, 1000 impulses in each direction

Test Fe: Earthquake test

- IEC 60068-3-3, KTA 3503, IEC 60255-21-3, Class 2
 - Single axis earthquake vibration test:
 - 3–7 Hz: horizontal 0.394 in (10 mm), 1 cycle each axis
 - 7–35 Hz: horizontal: 2 gn, 1 cycle each axis

Tolerances**Tolerances of the Real-Time Clock**

- Resolution: 1 ms
- Tolerance:
 - < 1 minute/month (68 °F [$+20$ °C])
 - $< \pm 1$ ms if synchronized via IRIG-B

Tolerances of the Measured Value Acquisition

Phase and ground current measuring

- Maximum measuring range:
 - Up to $40 \times I_n$ (phase currents)
 - Up to $25 \times I_n$ (ground current standard)
 - Up to $2.5 \times I_n$ (earth current sensitive)

Note: The precision does not depend on the nominal value but is referenced to 100 mA (with $I_n = 1$ A) respectively, 500 mA (with $I_n = 5$ A)

- Frequency range: 50 Hz / 60 Hz $\pm 10\%$
- Accuracy: Class 0.5
- Amplitude Error if $I < 1 I_n$: $\pm 0.5\%$ of the rated value
- Amplitude Error if $I > 1 I_n$: $\pm 0.5\%$ of the measured value
- Amplitude Error if $I > 2 I_n$: $\pm 1.0\%$ of the measured value
- Resolution: 0.01 A
 - Harmonics: Up to 20% 3rd harmonic $\pm 1\%$
 - Up to 20% 5th harmonic $\pm 1\%$
- Frequency influence: $< \pm 2\%$ / Hz in the range of ± 5 Hz of the parametrized nominal frequency
- Temperature influence: $< \pm 1\%$ within the range of $+32$ °F to $+140$ °F (0 °C to $+60$ °C)

Wiring Diagrams

Typical AC Connections Delta-Wye Transformer with Wye CTs and Neutral CT

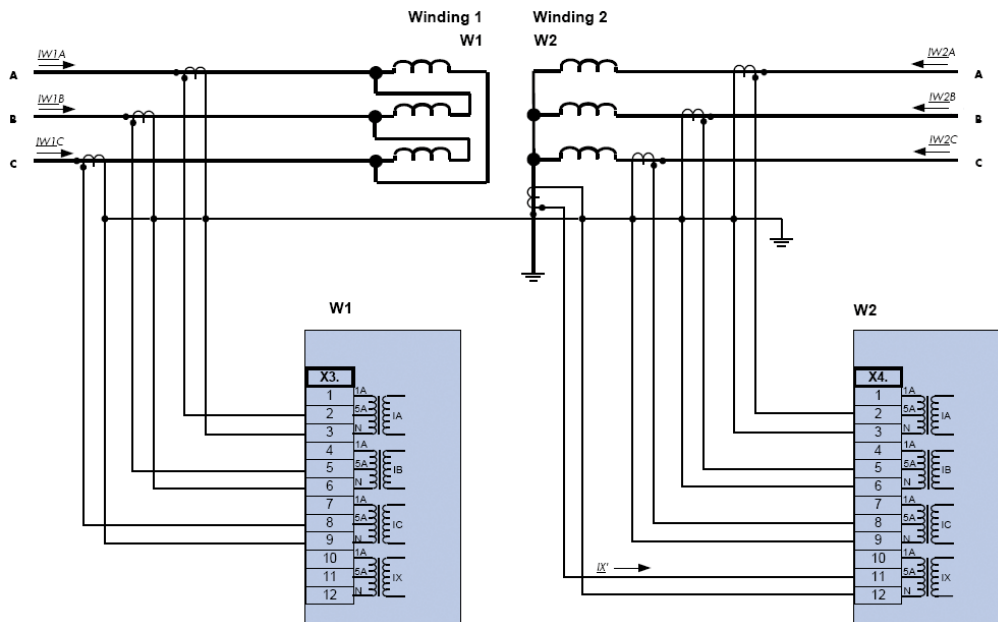

Typical One-Line Diagram

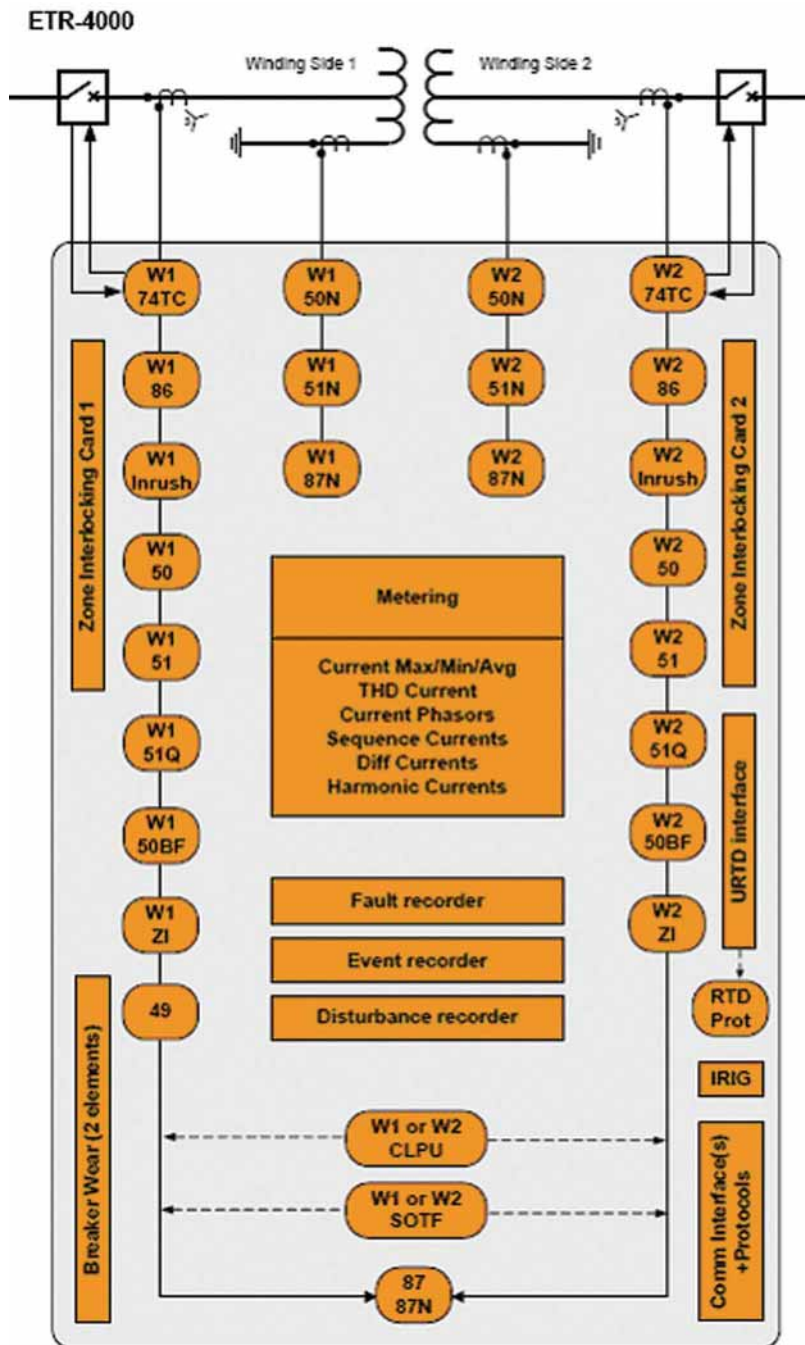

Typical Control Diagram

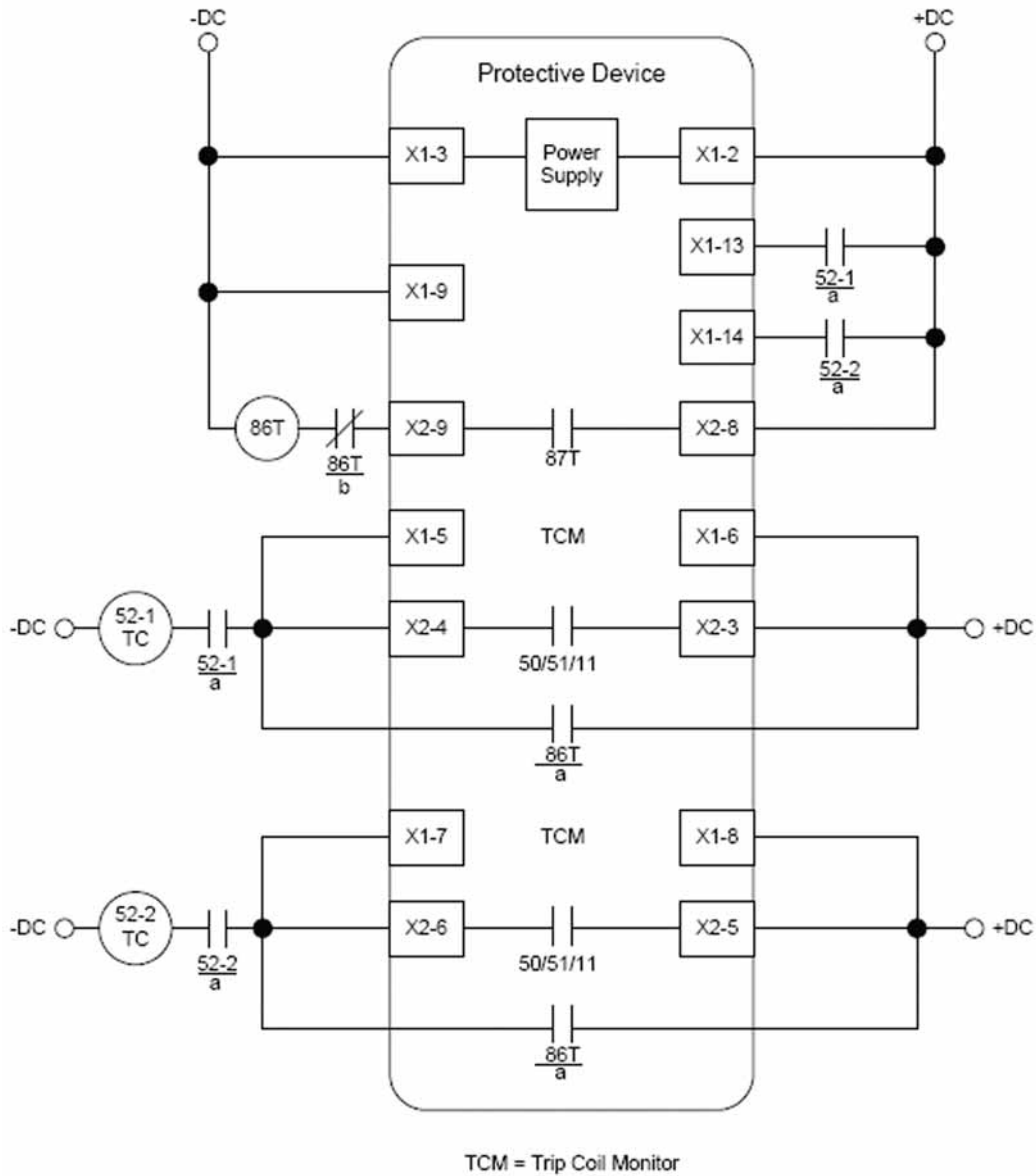

Dimensions

Approximate Dimensions in Inches (mm)

Drilling Plan

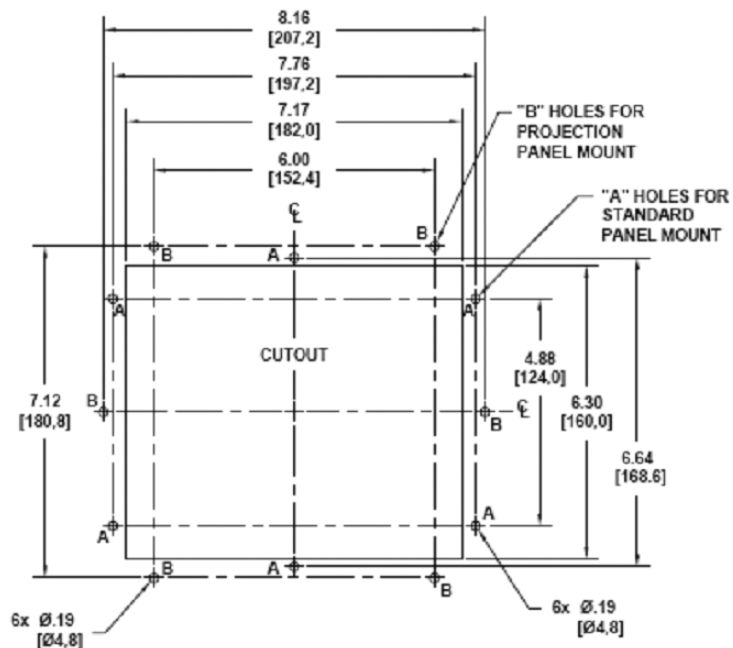

Projection Mount Front and Side Views

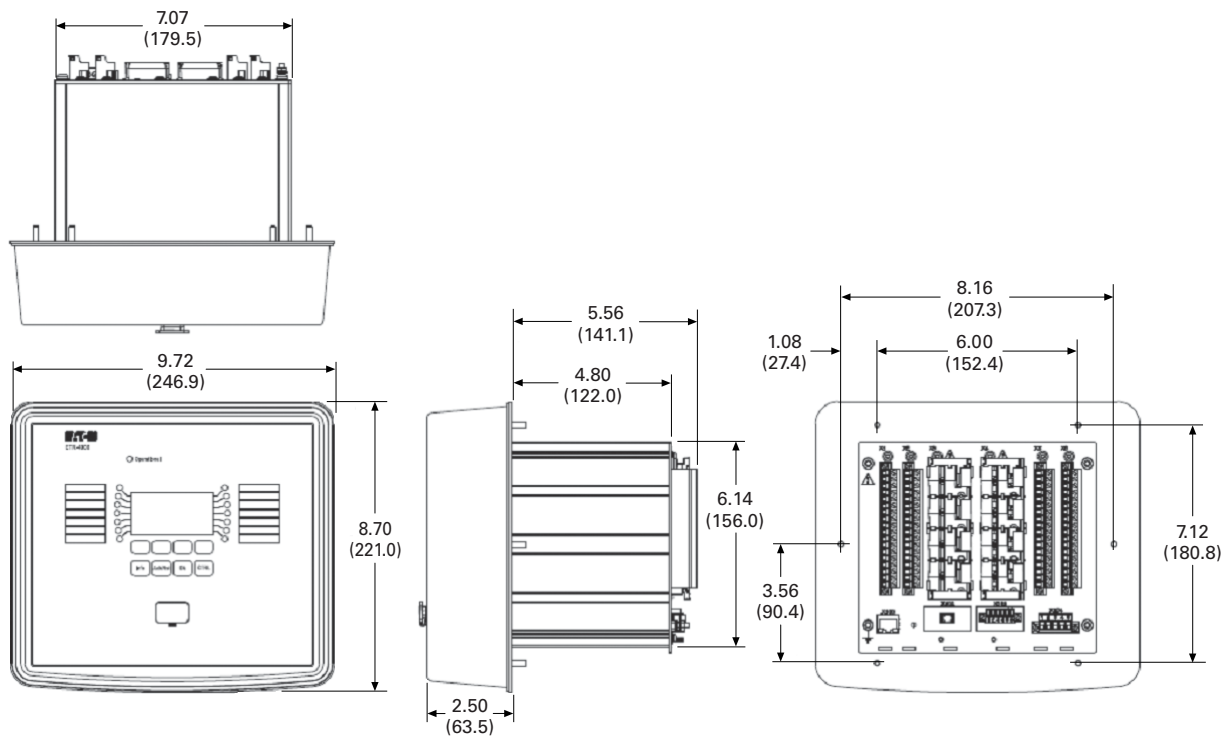

Approximate Dimensions in Inches (mm)

Standard Mount Front and Side Views

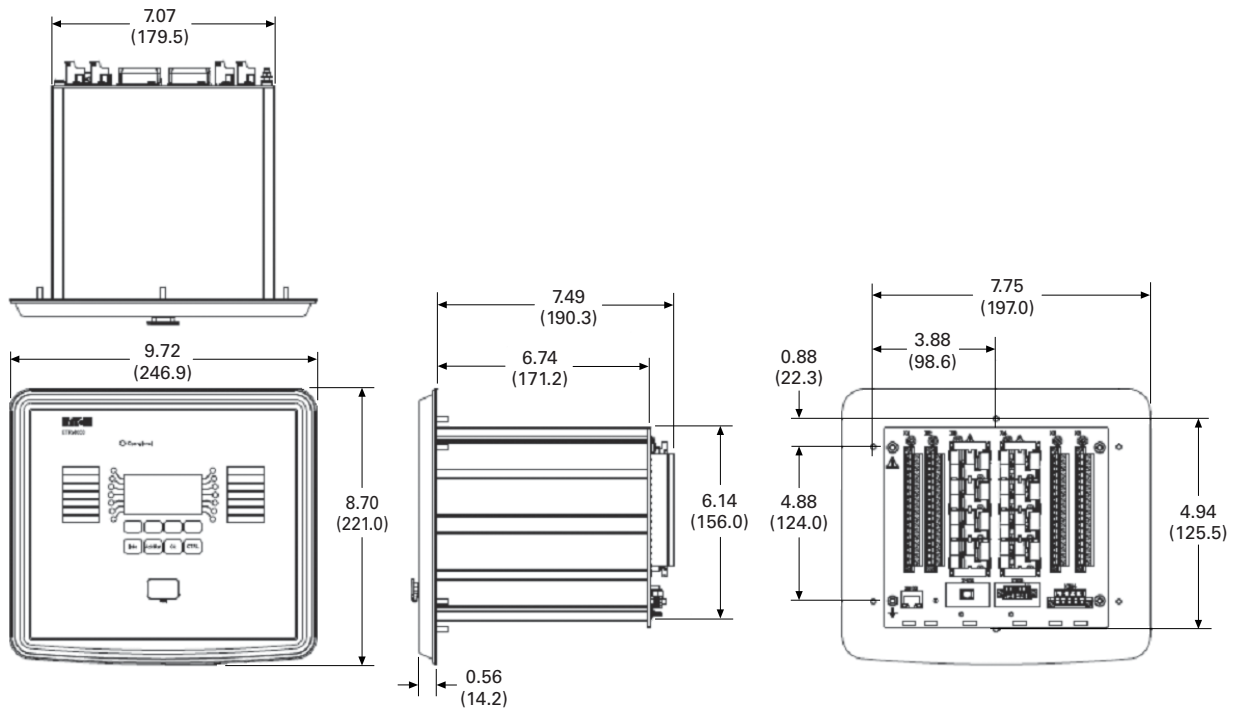

ETR-4000 Housing B2

Width	Height	Depth ^①	Shipping Weight Lbs (kg)
6.81 (173.0)	8.37 (212.7)	8.19 (208.0)	9.3 (4.2)

Note

^① Includes terminals.

ETR-5000 Transformer Protection Relay



Contents

<i>Description</i>	<i>Page</i>
Product Selection Guide	V3-T9-117
Digitrip 3000	V3-T9-123
EDR-3000 Feeder Protection	V3-T9-133
EDR-5000 Distribution Protection Relay	V3-T9-142
FP-5000 Feeder Protection	V3-T9-155
MP-3000 Motor Protection	V3-T9-163
MP-4000 Motor Protection	V3-T9-173
EMR-3000 Motor Protection Relay	V3-T9-179
EMR-4000 Motor Protection Relay	V3-T9-191
EMR-5000 Motor Protection Relay	V3-T9-204
ETR-4000 Transformer Protection Relay	V3-T9-216
ETR-5000 Transformer Protection Relay	V3-T9-241
EGR-5000 Generation Protection Relay	V3-T9-254
Ground Fault Relay	V3-T9-254
Universal RTD Module	V3-T9-257

ETR-5000 Transformer Protection Relay

Product Description

Eaton's ETR-5000 transformer protection relay is a multi-functional, microprocessor-based relay for two winding transformers of all voltage levels. The ETR-5000 provides phase and ground percentage restrained differential protection using a variable dual slope characteristic with phase, residual, and neutral directional overcurrent elements for backup protection. Negative sequence overcurrent elements, three phase over/under voltage, voltage unbalance, current unbalance, over/under and rate-of-change frequency, vector surge, directional VARs, directional power, and overexcitation are standard functions.

The ETR-5000 transformer relay provides all required protection, control, monitoring and metering for any size two winding transformer in a single, compact case. The relay has eight current inputs rated for either 5 amperes or 1 ampere and four voltage inputs. The CTs can be connected in wye in both sides of the transformer; the relay automatically compensates for the connection of the transformer, and CT mismatch errors.

Three of the voltage inputs are to be connected to the three-phase power voltage for voltage protection and for metering. They can be connected in wye-ground or open delta configuration. The fourth voltage is for independent single-phase undervoltage/overvoltage protection.

The maintenance mode password protected soft key, can be used for arc flash mitigation to change to an alternate settings group, set to have instantaneous elements only.

An integral keypad and display is provided for direct user programming and retrieval of data without the need of a computer. Fourteen programmable LEDs provide quick indication of relay status.

A front port is provided for direct computer connection. An RS-485 and an Ethernet ports in the back are optional for local area networking using. Optional Modbus-RTU, Modbus-TCP, or IEC-61850 protocols are supported.

The ETR-5000 transformer protection relay includes programmable logic functions. Logic gates and timers may be defined and arranged for customized applications. Programmable logic control functions make the ETR-5000 very flexible.

Flash memory is used for the programming and all settings are stored in nonvolatile memory.

The ETR-5000 generator protection relay has mass memory for data storage and a real-time clock with 1 ms time resolution. The relay will log 300 sequence of event records, 20 detailed trip logs, minimum/maximum values, load profiles, breaker wear information and waveform data.

The ETR-5000 has eight programmable binary inputs, 2 analog inputs, 2 analog outputs, 1 zone interlocking card or eight programmable binary inputs, and 2 zone interlocking cards. It has 2 normally opened and 6 Form C heavy-duty outputs and one Form C signal alarm relay. The ETR-5000 can be powered from 19 Vdc to 300 Vdc or 40 Vac to 250 Vac auxiliary power.

Application Description

Eaton’s ETR-5000 transformer protection relay has been designed for maximum user flexibility and simplicity. The ETR-5000 is suitable for application on small, medium, and large two winding power transformers. Multiple current inputs are used to provide primary protection, control and back-up protection of transformers, including current differential, restricted ground differential, and overcurrent protection.

Dual-Slope Percent Differential Protection

The primary protective element for transformer protection is the percent differential element, which compares the current entering the primary and leaving the secondary of the transformer. The ETR-5000 has built in compensation for the turns-ratio and the phase shift of the transformer, so it’s not necessary to compensate for the transformer connection by the connection of the CTs.

The current differential element looks at the vector difference between the current entering and leaving the zone of protection. If the difference exceeds a pre-determined amount, the element will operate.

The operating characteristic of the percent differential element is a dual-slope characteristic to accommodate for CT saturation and CT errors.

Harmonic Restraints

There are certain conditions like energizing one side of the transformer with the other side de-energized (inrush currents) or the paralleling of two transformers (sympathetic currents) that can create false differential currents. These differential currents if not recognized can cause a false trip; in the case of inrush conditions or sympathetic currents the differential current is characterized by a heavy content of 2nd and 4th harmonic currents. The percentage differential element is desensitize either permanently (stationary conditions) or temporarily (transient conditions), whenever the 2nd or 4th harmonic exceed the value programmed into the relay.

Another condition that can create a false differential current is a sudden change of voltage or frequency, that can put the transformer in an overexcitation state. In this case there is high content of 5th harmonic currents. The percentage differential element is also desensitized when the 5th harmonic content exceeds a predefined value.

Unrestrained Differential

An unrestrained differential element is provided for fast tripping on heavy internal faults to limit catastrophic damage to the transformer and minimize risks to the remainder of the power system.

Restricted Ground Fault

Ground differential protection is applied to transformers having impedance grounded wye windings. It is intended to provide sensitive ground fault detection for low magnitude fault currents, which would not be detected by the main percent differential element.

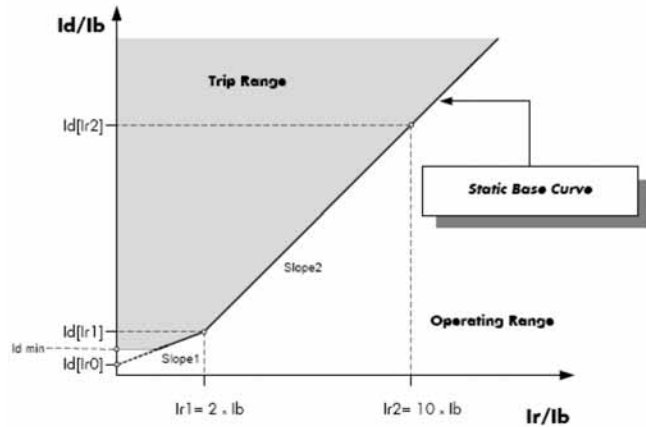

Dual-Slope Operating Characteristic

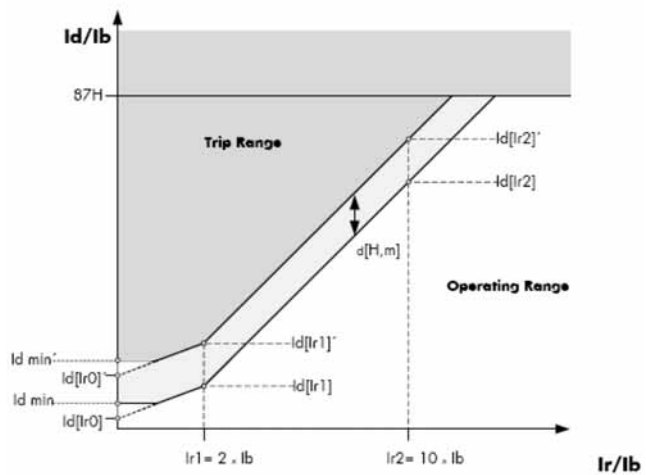

Dynamic Rise of the Operating Characteristic.

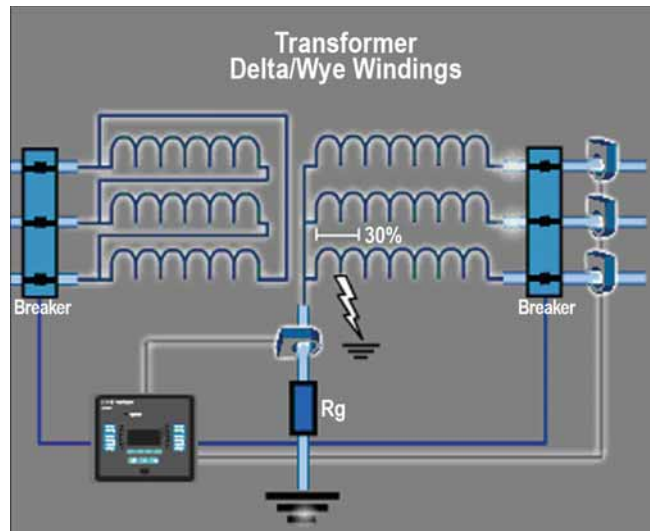

Restricted Ground Fault

Directional Overcurrent Elements

The ETR-5000 can be used to provide backup for transformer and adjacent power system equipment. Instantaneous overcurrent elements can be used for fast clearing of severe internal or external (through) faults.

Time overcurrent protection elements per winding allow coordinating with the adjacent protection zones and acting as a backup protection. There are 11 user-selectable inverse-time overcurrent curve characteristics. The user can select from the ANSI, IEC or thermal curve families and can select instantaneous or time delay reset characteristics.

Phase direction is a function used to supervise all phase current elements (50, 51). A quadrature voltage is compared to a corresponding phase current to establish the direction of the fault. This function is selectable to operate in the forward, reverse or both directions.

Ground direction is used to supervise ground current elements and is accomplished by using ground, negative sequence or residual currents supervised by zero, negative or positive sequence voltages or ground current. This function is selectable to operate in forward, reverse or both directions.

Directional elements are dependant on the location of the VTs (primary or secondary winding) when voltage is used as the polarizing quantity.

Negative Sequence Overcurrent

Since this element does not respond to balanced load or three-phase faults, the negative-sequence overcurrent element may provide the desired overcurrent protection. This is particularly applicable to delta-wye grounded transformers where only 58% of the secondary p.u. phase-to-ground fault current appears in any one primary phase conductor. Backup protection can be particularly difficult when the wye is impedance grounded. A negative-sequence element can be used in the primary supply to the transformer and set as sensitively as required to protect for secondary phase-to-ground or phase-to-phase faults. This element should be set to coordinate with the low-side phase and ground relays for phase-to-ground and phase-to-phase faults. The negative sequence element must also be set higher than the negative-sequence current due to unbalanced loads.

Overexcitation Protection

Transformer overexcitation occurs when the ratio of voltage versus frequency is too high, and the transformer iron saturates due to high flux density. High flux density results in stray flux in components not designed to carry it, which in turn causes overheating and can potentially damage the transformer. This protection is provided through a Volts/Hertz function with a programmable inverse time characteristic.

Voltage Protection

The ETR-5000 transformer protection relay has four voltage-input circuits. There is a three-phase set designated as Main Voltage (M) and a single-phase voltage circuit designated as Auxiliary Voltage (A). Both include undervoltage (27) and overvoltage (59) protection. The three-phase voltage protection can be set to operate on a single-phase, 2 out of 3 phases, or all three-phase logic. The Main VTs also provide phase voltage unbalance/reversal (47 negative sequence) protection. Each element has an independent threshold set point and adjustable time delay.

Flexible Phase Rotation

The ETR-5000 distribution protection relay can be applied on either an A-B-C or A-C-B phase rotation. A user setting permits correct operation and indication of the actual system configuration.

Frequency Protection

The ETR-5000 relay provides six frequency elements than can be used to detect under/over frequency, rate of change, and a vector surge (decoupling of two systems) protection on the Main VT inputs. Each element has an independent threshold set point and adjustable time delay.

Reverse Power

Reverse power provides control for power flowing through a feeder. There are three elements to be configured: operate in forward or reverse; or, under or over power conditions. Reverse power is typically applied to generator or motor applications while under power is generally applied to load or generation loss.

Reverse VARs

Reverse VARs can be used to detect loss of excitation in synchronous machines. There are three elements to be configured: operate in forward or reverse; or, under or over vars conditions.

Breaker Failure

The ETR-5000 transformer protection relay includes two breaker failure (50BF, 62BF) elements that can be initiated from either an internal or external trip signal. These are independent elements that can be used to operate a lockout relay or trip an upstream breaker. The timer must be longer than the breaker operating time and the protective function reset times.

Maintenance Mode

The Maintenance Mode can improve safety by providing a simple and reliable method to reduce fault clearing time and lower incident energy levels at energized panels. The Maintenance Mode allows the user to switch to more sensitive settings via a password protected soft key, communications or via a digital input while maintenance work is being performed at an energized panel or device. The more sensitive settings provide greater security for maintenance personnel and helps reduce the possibility of injury.

Features, Benefits and Functions

Protection Features

- Dual-slope percentage restrained current differential with magnetizing inrush and overexcitation blocking (87R)
- Unrestrained current differential (87H)
- Restricted ground fault/ Ground Differential (87GD)
- Phase overcurrent (elements can be assigned to either side of the transformer):
 - Four instantaneous elements with timers (50P[1], 50P[2], 50P[3] and 50P[4])
 - Four inverse time overcurrent elements (51P[1], 51P[2], 51P[3] and 51P[4])
 - 11 standard curves;
 - Inrush blocking
 - Instantaneous or time delay reset
 - Voltage restraint (all elements)
 - Directional control (all elements)
- Negative sequence phase overcurrent (elements can be assigned to either side of the transformer):
 - 2 inverse time overcurrent elements (51Q[1] and 51Q[2])
 - 11 standard curves
 - Instantaneous or time delay reset
- Ground overcurrent (elements can be assigned to either side of the transformer):
 - Two instantaneous measured elements with timers (50X[1] and 50X[2])
 - Two instantaneous calculated elements with timers (50R[1] and 50R[2])
 - Two inverse time overcurrent measured elements (51X[1] and 51X[2])
 - Two inverse time overcurrent calculated elements (51R[1] and 51R[2])
- 11 standard curves
- Instantaneous or time delay reset
- Directional control (all elements)
- Two breaker failure elements (50BF[1] and 50BF[2])
- Phase transformer overload protection (49)
- Phase unbalance negative sequence overcurrent (46[1], 46[2])
- Phase voltage unbalance and sequence protection (47[1], 47[2])
- Main three-phase under/overvoltage (27M[1], 27M[2], 59M[1], 59M[2])
- Auxiliary single-phase under/overvoltage (27A[1], 27A[2], 59A[1], 59A[2])
- Six frequency elements that can be assigned to: over frequency, under frequency, rate of change, or vector surge (81[1], 81[2], 81[3], 81[4], 81[5], 81[6])
- Forward and reverse watts (32[1], 32[2], 32[3]).
- Forward and reverse VARs (32V[1], 32V[2], 32V[3])
- Overexcitation, volts-per-Hertz (24[1], 24[2])
- Lockout (86)
- Loss of potential-LOP
- Zone interlocking for bus protection (87B)
- Switch onto fault protection
- Cold load pickup

Metering Features

- Phase differential current
- Ground differential current
- Amperes: positive, negative and zero sequence
- Ampere demand
- Volts: positive, negative and zero sequence
- Phase angles
- Volt-amperes and VA demand
- Watts and kW demand
- kWh (forward, reverse, net)
- VARs and kVAR demand
- kVARh (lead, lag and net)
- Power factor
- Volts/Hertz
- % THD V and I
- Magnitude THD V and I
- Minimum/maximum recording
- Trending (load profile over time)
- Temperature with remote URTD module

Monitoring Features

- Trip coil monitor for both primary and secondary breakers
- Breaker wear primary and secondary (accumulated interrupted current)
- Oscillography (7200 cycles total)
- Trip Cause displays fault recorder data on HMI after fault event
- Fault data logs (up to 20 events)
- Sequence of events report (up to 300 events)
- Clock (1 ms time stamping)

Control Functions

- Breaker open/close both breakers
- Remote open/close
- Programmable I/O
- Programmable Logic
- Programmable LEDs
- Multiple setting groups
- Cold load pickup
- CT supervision

Communication Features

- Local HMI
- Password protected
- Addressable
- IRIG-B
- Local communication port: RS-232
- Remote communication port:
 - RS-485
 - Ethernet port
- Protocols:
 - Modbus-RTU
 - Modbus-TCP (optional)
 - IEC-61850 (optional)
- Configuration software

Monitoring and Metering

Sequence of Events Records

The ETR-5000 protection relay records a maximum of 300 events associated with the relay. An event is classified as a change of state as detected by the relay. These include relay pickups, dropouts, trips, contact closure, alarms, setting changes and self-diagnostic failures. Each event is date and time stamped to a 1 ms resolution. The events are stored in a FIFO in chronological order.

Trip Log

The ETR-5000 protection relay will store a maximum of 20 trip records in a FIFO trip log. Each trip record will be date and time stamped to a 1 ms resolution. The trip log record will include information on the type of fault, protection elements that operated, fault location and currents and voltages at the time of the fault.

PowerPort-E

PowerPort-E is the software program used to configure off-line protection setting files for all E-Series relay models. PowerPort-E is also used for

viewing measured values of the relays in real-time, uploading/downloading setting files, and retrieving event log and waveform records.

Waveform Capture (Quality Manager)

The ETR-5000 relay provides oscillographic recording capabilities. The relay will record all measured signals along with the binary signals of pickup, trip, internal logic, and contact inputs. The ETR-5000 can record up to 7200 cycles of data. The number of records is proportional to the programmed size of each record; the maximum size per record is 600 cycles.

The waveform capture is initiated by up to 8 different triggers (i.e., trip/alarm events) or manually via communications or the HMI. PowerPort-E setting software is used to retrieve the records. Quality Manager is a separate software program downloaded with PowerPort-E used for analyzing the waveform and trending files retrieved from the relay.

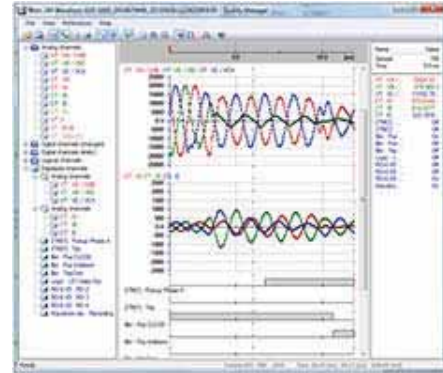

Waveform Capture (Quality Manager)

Integral User Interface

The front panel user interface has a 128 x 64 pixel LCD display with background illumination for wide angle viewing in all light conditions. 14 programmable LEDs provide quick and easy visual display of power on, mode of operation, alarm and trip indication. Soft keys are provided for operation mode selection, scrolling through data and settings. In addition, the relay settings and test functions are password protected.

Load Profiling/Trending

The ETR-5000 relay automatically records selected quantities into non-volatile memory every 5, 10, 15, 30 or 60 minutes, depending on the trending report setting.

Programmable I/O

The ETR-5000 transformer protection relay provides heavy-duty, trip-rated, 2NO and 6 Form C contacts. Two isolated inputs can be used for monitoring the trip circuit. One Form C contact is dedicated to the relay failure alarm function and is operated in a normally energized (failsafe) mode. There are up to 8 user-configurable discrete inputs that accept a wet contact and can operate through a wide range of power. Each input and output is user-programmable for maximum application flexibility.

The ETR-5000 also offers two optional analog inputs and two optional analog outputs. The analog inputs are available for providing protection. The analog inputs are field programmable to measure transducer signals that operate over a range of 0 to 20 mA, 4 to 20 mA, or 1 to 10V. The two optional analog outputs can be used for signaling the value of measured analog quantities to external process control devices such as PLCs. They can be programmed to operate over a 0 to 20 mA, 4–20 mA, or 1 to 10 V range. The analog outputs can be configured to signal a representation of most analog quantities measured by the ETR-5000 including, current, voltages and RTD temperature.

Programmable Logic

The ETR-5000 transformer protection relay provides logic gates and timers that the user can customize for special or unique applications. Each gate can be assigned a logic function of either AND, OR, NAND or NOR. Each gate can have a maximum of four input signals and each input signal can be required to be a NOT. Input signals can be external inputs received via the binary inputs or internal values associated with the protection, alarm or metering set points. Each gate has a unique output assignment and designation that can be used as the input to another gate.

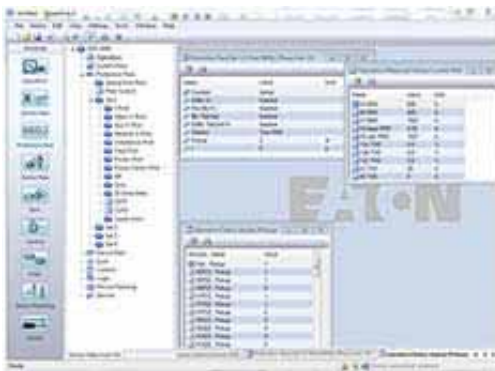

PowerPort-E

Standards and Certifications

Approvals

- UL listed file: E217753

Design Standards

- Generic Standard:
 - EN 61000-6-2
 - EN 61000-6-3
- Product Standard:
 - IEC 60255-6
 - EN 50178
 - UL 508 (Industrial Control Equipment)
 - CSA C22.2 No. 14-95 (Industrial Control Equipment)
 - ANSI C37.90



Catalog Number Selection

The catalog number identification chart defines the electrical characteristics and operation features included in the ETR-5000. For example, if the catalog number is ETR-5000-2A0BA1, the device would have the following:

- ETR-5000
- (A)—8 Digital Inputs, 9 Output Relays
 - (0)—5 A / 1 A phase and ground CTs, Power Supply Range: 19–300 Vdc, 40–250 Vac
 - (B)—Modbus-RTU (RS-485)
 - (A)—Without Conformal Coating
 - (1)—Projection Panel Mount

ETR-5000 Eaton Transformer Protection Relay

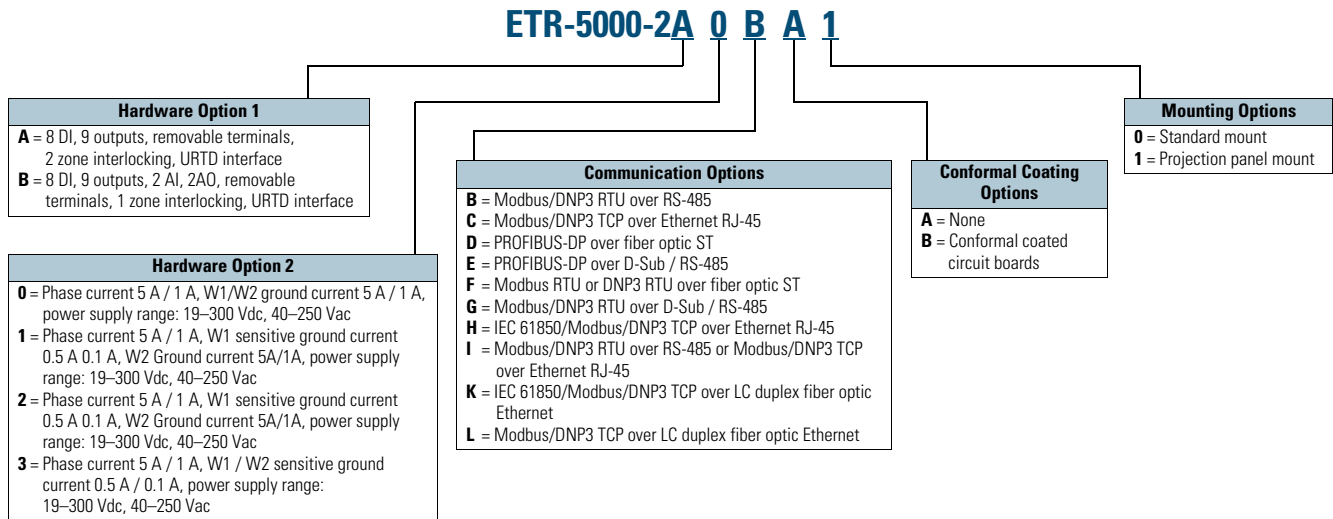

Technical Data and Specifications

Climatic Environmental Conditions

- Storage temperature: –30 °C to +70 °C (–22 °F to +158 °F)
- Operating temperature: –20 °C to +60 °C (–4 °F to +140 °F)
- Permissible humidity at ann. average: <75% rel. (on 56d up to 95% rel.)
- Permissible installation altitude:
 - <2000 m (6,561.67 ft) above sea level
 - If 4000 m (13,123.35 ft) altitude applies, a changed classification of the operating and test voltages may be necessary

Degree of Protection EN 60529

- HMI front panel with seal: IP54
- Rear side terminals: IP30

Routine Test

- Insulation test acc. to IEC 60255-5: All tests to be carried out against ground and other input and output circuits.
- Aux. voltage supply, digital inputs: 2.5 kV (eff.) / 50 Hz
- Current measuring inputs, signal relay outputs: 2.5 kV (eff.) / 50 Hz
- Voltage measuring inputs: 3.0 kV (eff.) / 50 Hz
- All wire-bound communication interfaces: 1.5 kV DC

Housing

- Housing B2: height/width: 173 mm (6.811 in / 4 U) / 212.7 mm (8.374 in / 42 hp)
- Housing depth (incl. terminals): 208 mm (8.189 in)
- Material, housing: aluminum extruded section
- Material, front panel: aluminum/foil front
- Mounting position: horizontal ($\pm 45^\circ$ around the X-axis must be permitted)
- Weight: ETR-5000 housing B2: approx. 9.259 lb (4.2 kg)

Plug-in Connector with Integrated Short-Circuiter

(Conventional current inputs)

- Nominal current: 1 A and 5 A
- Continuous loading capacity: 4 x In / continuously
- Overcurrent withstand:
 - 30 x In / 10 s
 - 100 x In / 1 s
 - 250 x In / 10 ms (1 half-wave)
- Screws: M4, captive type acc. to VDEW
- Connection cross sections:
 - 1 x or 2 x 2.5 mm² (2 x AWG 14) with wire end ferrule
 - 1 x or 2 x 4.0 mm² (2 x AWG 12) with ring cable sleeve or cable sleeve
 - 1 x or 2 x 6 mm² (2 x AWG 10) with ring cable sleeve or cable sleeve

Control power supply

- Aux. voltage: 24–270 Vdc / 48–230 Vac (–20/+10%)
- Buffer time in case of supply failure:
 - ≥ 50 ms at minimal aux. voltage
 - Interrupted communication is permitted
- Max. permissible making current:
 - 18 A peak value for <0.25 ms
 - 12 A peak value for <1 ms
- The voltage supply must be protected by a fuse of:
 - 2.5 A time-lag miniature fuse 5 x 20 mm (approx. 1/5 x 0.8 in) according to IEC 60127
 - 3.5 A time-lag miniature fuse 6.3 x 32 mm (approx. 1/4 x 1 1/4 in) according to UL 248-14

Power Consumption

- Power supply range: 19–300 Vdc
 - Power consumption in idle mode—7 W
 - Maximum power consumption—13 W
- Power supply range: 40–250 Vac (for frequencies of 40–70 Hz)
 - Power consumption in idle mode—7 W
 - Maximum power consumption—13 W

Real Time Clock

- Running reserve of the real time clock: 1 year min.

Display

- Display type: LCD with LED background illumination
- Resolution—graphics display: 128 x 64 pixel
- LED type: two colored: red/green
- Number of LEDs, Housing B2: 15

Digital Inputs

- Max. Input Voltage: 300 Vdc / 270 Vac
 - Input Current: <4 mA
 - Reaction Time: <20 ms
 - Fallback Time: <30 ms
- (Safe state of the digital Inputs)
- 4 Switching thresholds: Un = 24 Vdc, 48 Vdc, 60 Vdc, 110 Vac / DC, 230 Vac / DC
 - Un = 24 Vdc
 - Switching threshold 1 ON: Min. 19.2 Vdc
 - Switching threshold 1 OFF: Max. 9.6 Vdc
 - Un = 48 V / 60 Vdc
 - Switching threshold 2 ON: Min. 42.6 Vdc
 - Switching threshold 2 OFF: Max. 21.3 Vdc
 - Un = 110 / 120 Vac / Vdc
 - Switching threshold 3 ON: Min. 88.0 Vdc / 88.0 Vac
 - Switching threshold 3 OFF: Max. 44.0 Vdc / 44.0 Vac
 - Un = 230 / 240 Vac / dc
 - Switching threshold 4 ON: Min. 184 Vdc / 184 Vac
 - Switching threshold 4 OFF: Max. 92 Vdc / 92 Vac
 - Terminals: screw-type terminal

Current and Ground Current Measurement

- Nominal currents: 1 A / 5 A
- Max. measuring range:
 - Up to 40 x I_n (phase currents)
 - Up to 25 x I_n (ground current standard)
 - Up to 2.5 x I_n (ground current sensitive)
- Continuous loading capacity: 4 x I_n/continuously
- Overcurrent proof:
 - 30 x I_n / 10 s
 - 100 x I_n / 1 s
 - 250 x I_n / 10 ms (1 half-wave)
- Power consumption:
 - Phase current inputs
 - At I_n = 1 A burden = 0.15 MVA
 - At I_n = 5 A burden = 0.15 MVA
 - Ground current input
 - At I_n = 1 A burden = 0.35 MVA
 - At I_n = 5 A burden = 0.35 MVA
- Frequency range: 50 Hz / 60 Hz ±10%
- Terminals: screw-type terminals with integrated short-circuiters (contacts)

Relay Outputs

- Continuous current: 5 A AC/DC
- Maximum make current:
 - 25 A AC/25 A DC up to 30 V for 4 s
 - 30 A/230 Vac according to ANSI IEEE Std. C37.90-2005
 - 30 A/250 Vdc according to ANSI IEEE Std. C37.90-2005
- Maximum breaking current:
 - 5 A AC up to 125 Vac
 - 5 A DC up to 30 V (resistive)
 - 0.3 A DC at 300 V
- Maximum switching voltage: 250 Vac/250 Vdc
- Switching capacity: 1250 VA
- Contact type: changeover contact or NO contact
- Terminals: screw-type terminals

Supervision Contact (SC)

- Continuous current: 5 A at 120/240 Vac or 30 Vdc
- Maximum switch-on current: 15 A 120/240 Vac or 30 Vdc (max. 4 s)
- Maximum breaking current:
 - 5 A Vac up to 2120/240 Vac
 - 5 A Vdc up to 30 Vdc
 - 0.4 A at 125 Vdc
- Contact type: 1 changeover contact
- Terminals: screw-type terminals

Time Synchronization IRIG

- Nominal input voltage: 5 V
- Connection: screw-type terminals (twisted pair)

Front Interface RS-232

- Baud rates: 115,200 baud
- Handshake: RTS and CTS
- Connection: 9-pole D-Sub plug

RS-485

- Master/slave: slave
- Connection: 6 screw-clamping terminals RM 3.5 mm (138 MIL) (terminating resistors internal)

Zone Interlocking

- Nominal input level: 5 V
- Nominal output level: 5 V
- Connection: screw-type terminals (twisted pair)

Wiring Diagrams

Typical AC Connections—Delta-Wye Transformer with CTs for Phase Overcurrent and Differential on Primary Side (W2) and Secondary Side (W1), Neutral CT for Ground Fault Protection and Open-Delta VT on Primary Side (W2)

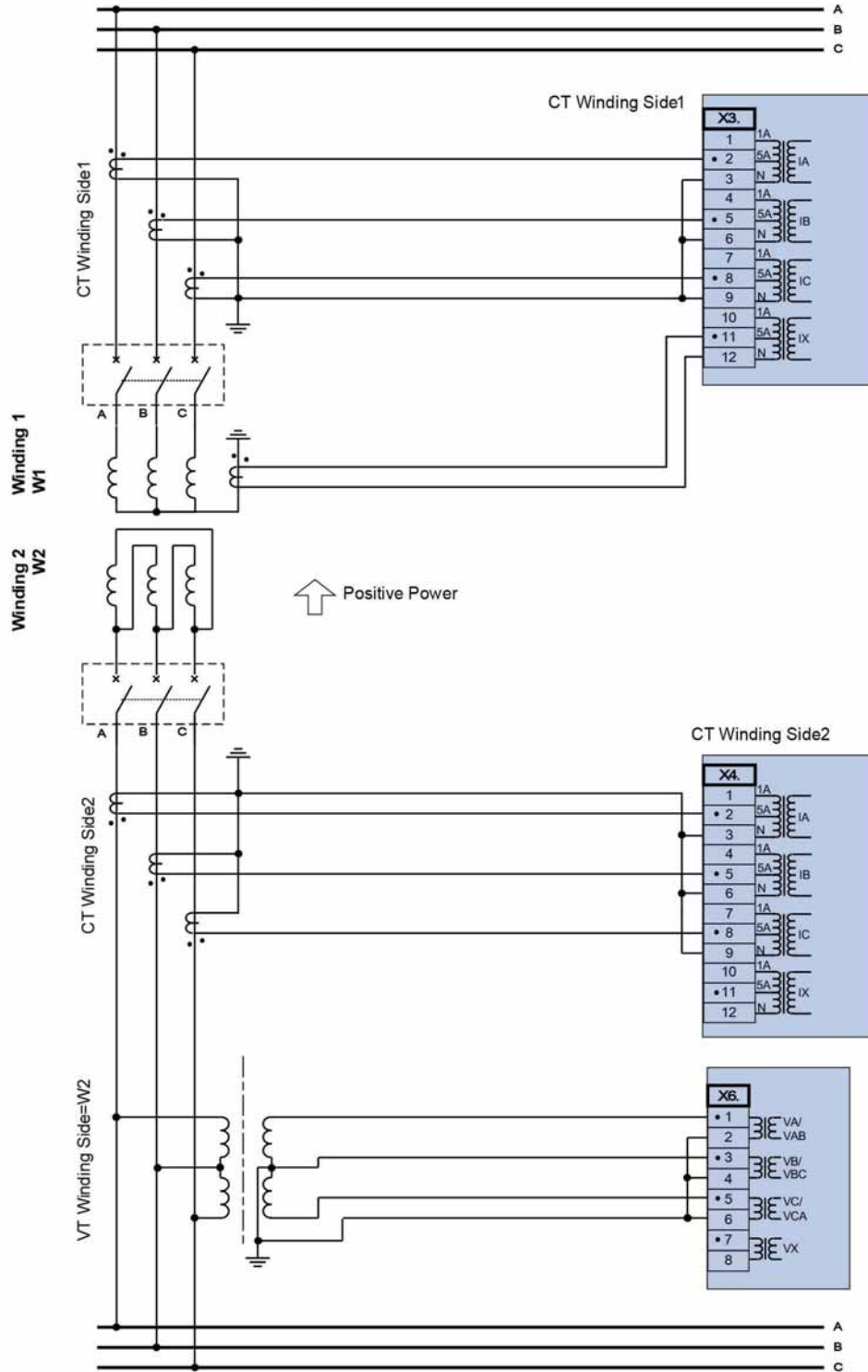

Typical One-Line Diagram

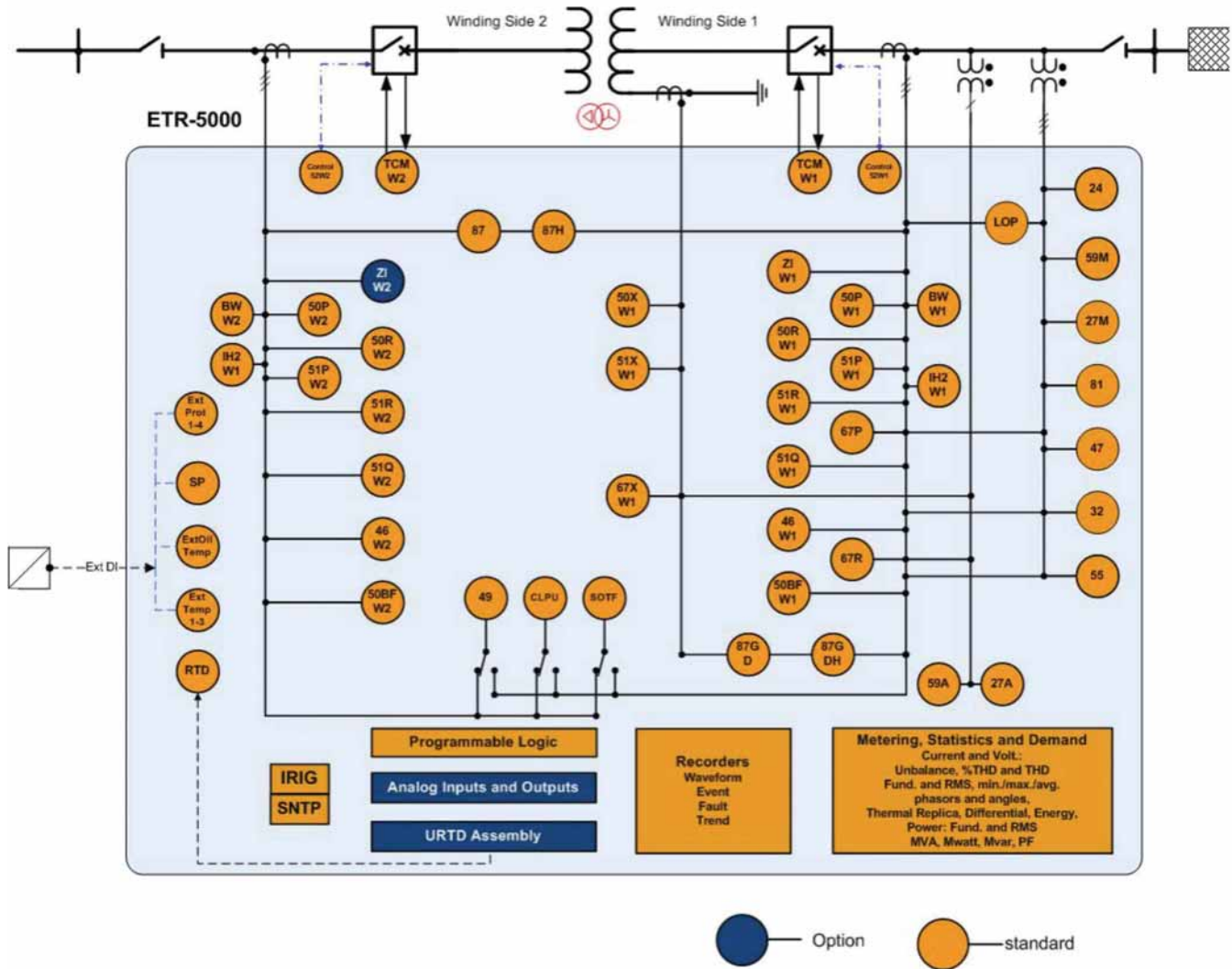

Typical Control Diagram

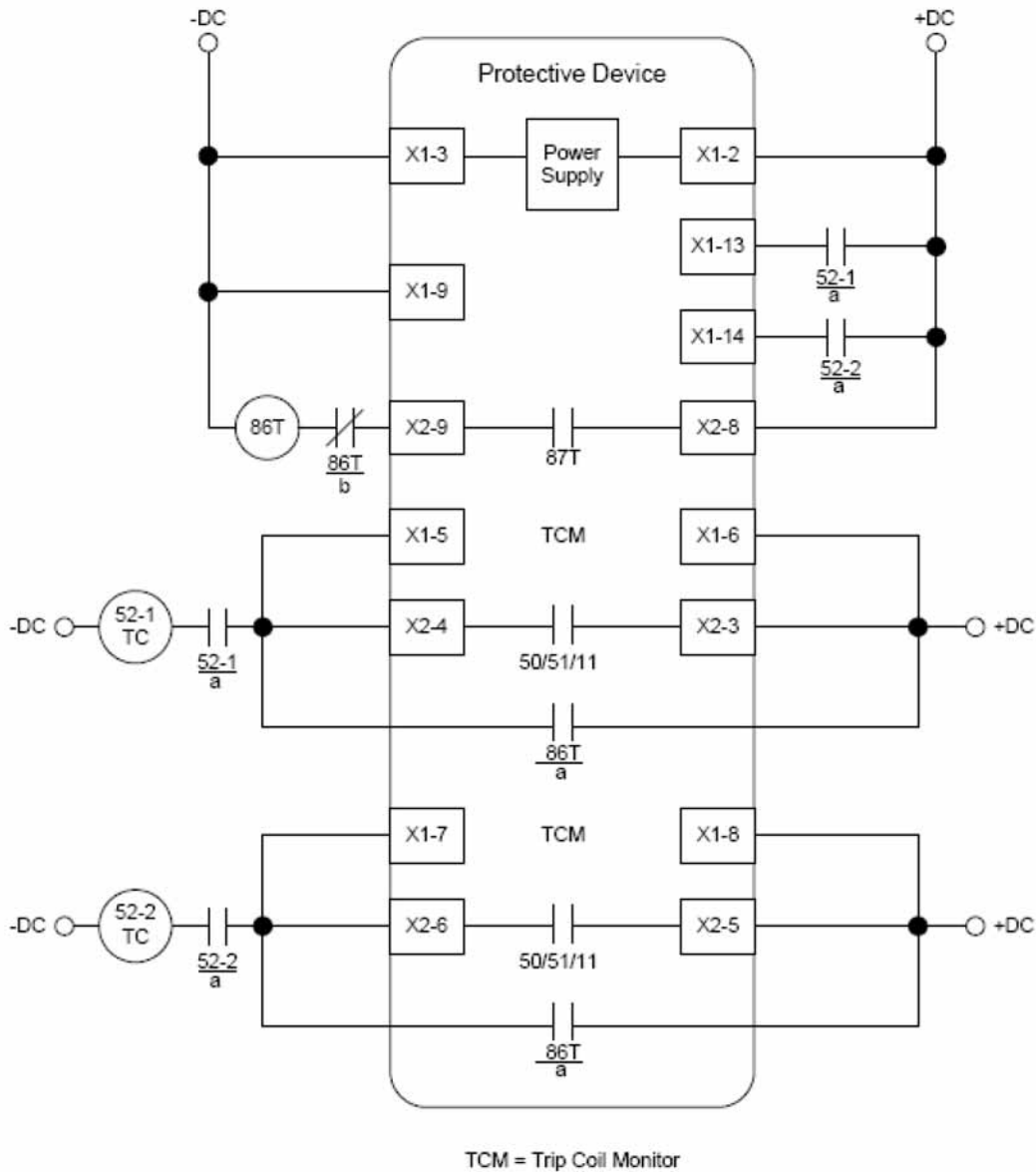

Dimensions

Approximate Dimensions in Inches (mm)

Drilling Plan

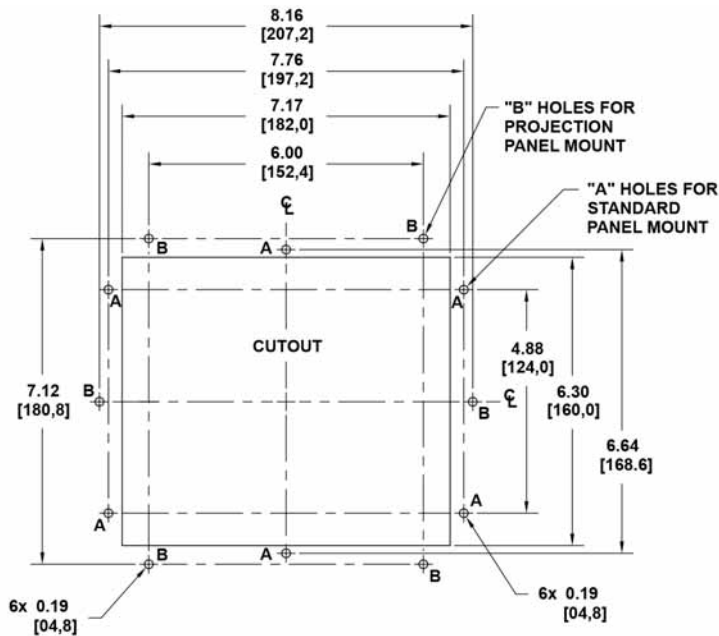

Projection Mount Front and Side Views

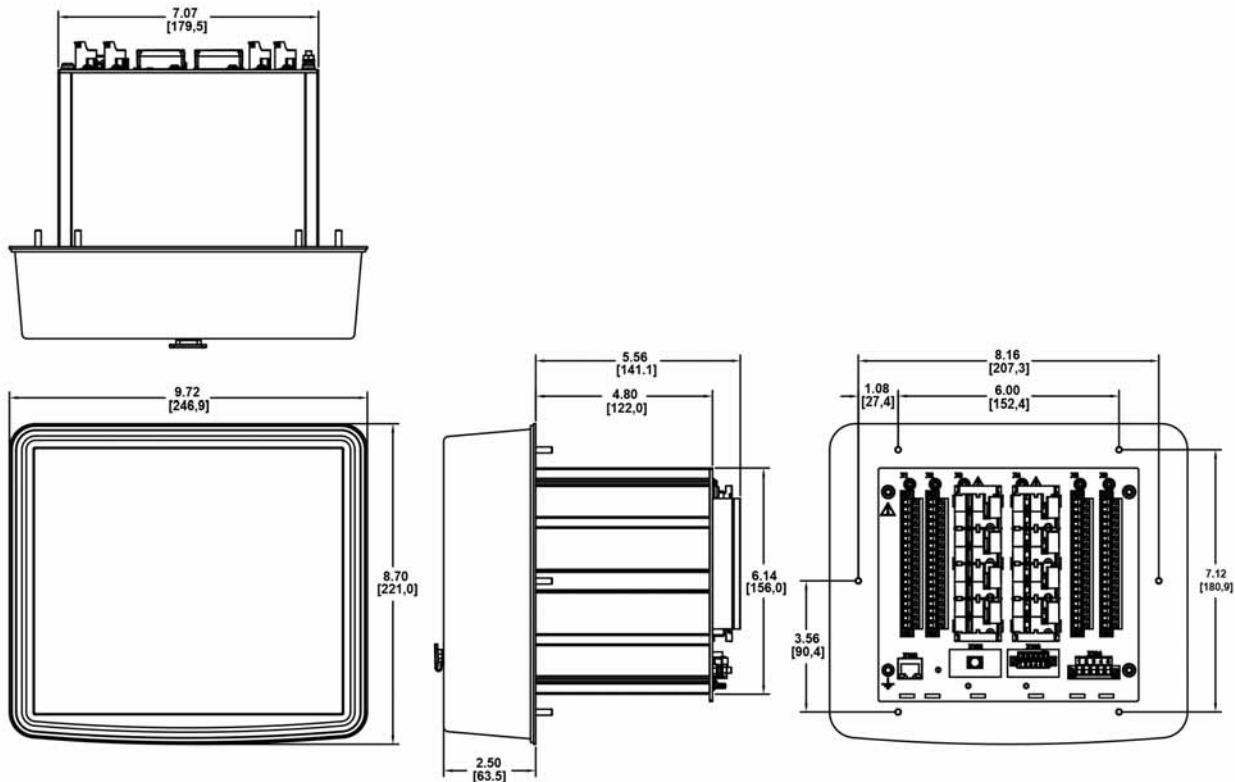

9.3

Metering Devices, Protective Relays, Software and Connectivity

Protective Relays

Approximate Dimensions in Inches (mm)

Standard Mount Front and Side Views

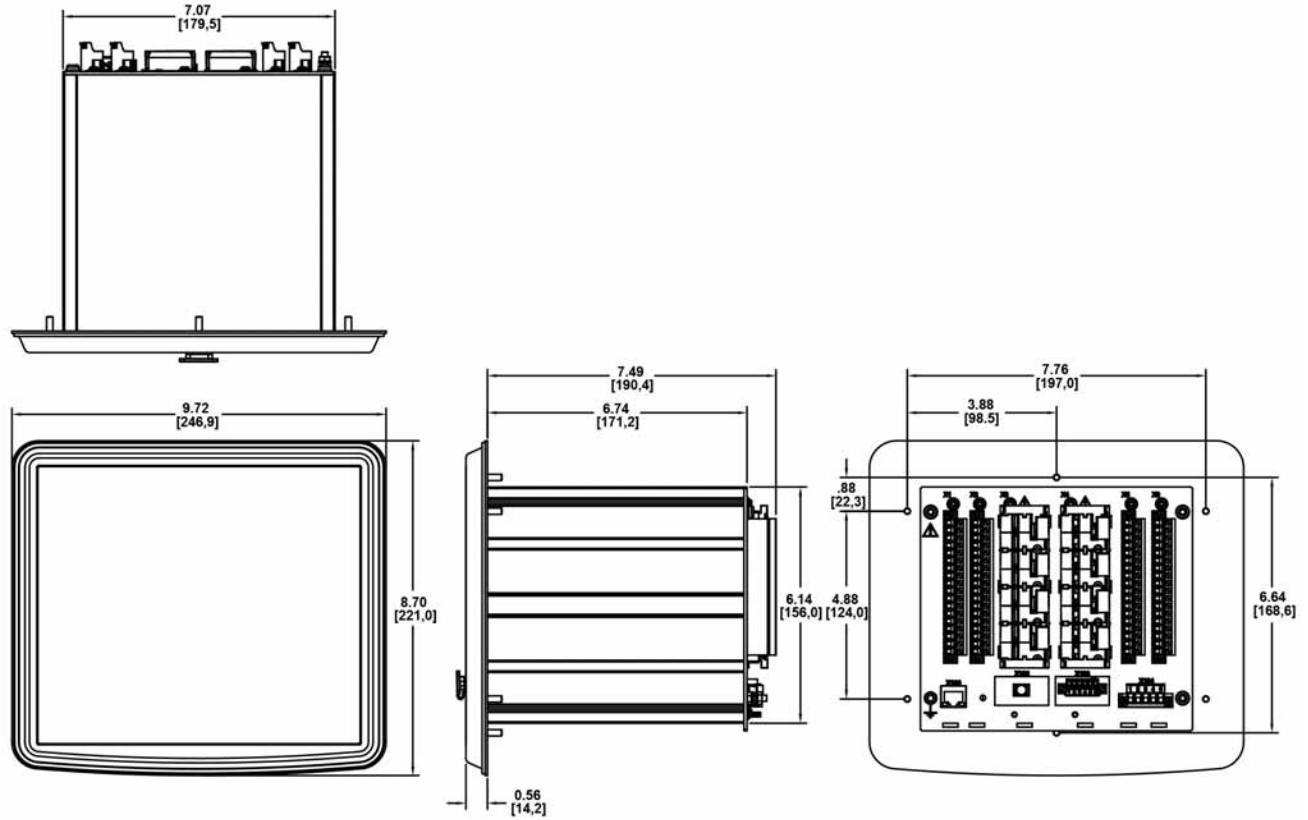

EGR-5000 Generation Protection Relay



Contents

<i>Description</i>	<i>Page</i>
Product Selection Guide	V3-T9-117
Digitrip 3000	V3-T9-123
EDR-3000 Feeder Protection	V3-T9-133
EDR-5000 Distribution Protection Relay	V3-T9-142
FP-5000 Feeder Protection	V3-T9-155
MP-3000 Motor Protection	V3-T9-163
MP-4000 Motor Protection	V3-T9-173
EMR-3000 Motor Protection Relay	V3-T9-179
EMR-4000 Motor Protection Relay	V3-T9-191
EMR-5000 Motor Protection Relay	V3-T9-204
ETR-4000 Transformer Protection Relay	V3-T9-216
ETR-5000 Transformer Protection Relay	V3-T9-228
EGR-5000 Generation Protection Relay	
Ground Fault Relay	V3-T9-254
Universal RTD Module	V3-T9-257

EGR-5000 Generation Protection Relay

Product Description

Eaton’s EGR-5000 generator protection relay is a multi-functional, microprocessor-based relay for any size generators. It may be used as a primary or backup protection in stand by generators, and cogeneration applications. The EGR-5000 generator protection relay provides voltage controlled, voltage restrained, and standard directional three phase overcurrent protection, as well as directional phase-residual and independent ground overcurrent protection, and breaker failure. Three phase over/under voltage, voltage unbalance, current unbalance, over/under and rate-of-change frequency, vector surge, power factor, directional VARs, directional power, loss of excitation, overexcitation, phase differential, ground differential, and synch check functions are standard functions.

The EGR-5000 generator relay provides all required protection, control, monitoring and metering for any size generators in a single, compact case. The relay has eight current inputs rated for either 5 amperes or 1 ampere and four voltage inputs. Three of the voltage inputs are to be connected to the three-phase power voltage for voltage protection and for metering. They can be connected in wye-ground or open delta configuration. The fourth voltage is for independent single-phase undervoltage/overvoltage protection, or 100% ground protection for a high resistance grounded generator.

The maintenance mode password protected soft key, can be used for arc flash mitigation to change to an alternate settings group, set to have instantaneous elements only. The multiple setting groups can also be changed, via communications or a digital input.

An integral keypad and display is provided for direct user programming and retrieval of data without the need of a computer. Fourteen programmable LEDs provide quick indication of relay status.

A front port is provided for direct computer connection. An RS-485 and an Ethernet ports in the back are optional for local area networking using. Optional Modbus-RTU, Modbus-TCP, or IEC-61850 protocols are supported.

The EGR-5000 generator protection relay includes programmable logic functions. Logic gates and timers may be defined and arranged for customized applications. Programmable logic control functions make the EGR-5000 very flexible. Flash memory is used for the programming and all settings are stored in nonvolatile memory.

The EGR-5000 generator protection relay has mass memory for data storage and a real-time clock with 1 ms time resolution. The relay will log 300 sequence of event records, 20 detailed trip logs, minimum/ maximum values, load profiles, breaker wear information and waveform data.

The EGR-5000 has either eight programmable binary inputs, 2 analog inputs, 2 analog outputs, or 16 programmable binary inputs. It has 2 normally opened and 6 Form C heavy duty outputs and one Form C signal alarm relay. The EGR-5000 can be powered from 19 Vdc to 300 Vdc or 40 Vac to 250 Vac auxiliary power.

Application Description

Eaton's EGR-5000 generator protection relay has been designed for maximum user flexibility and simplicity. The EGR-5000 provides comprehensive protection, metering, and monitoring for any size synchronous or induction generators operating at 50 or 60 Hz. The base relay includes all the standard protection and metering functions. Protection features found in the EGR-5000 include:

Phase Differential Protection

This protection provides a method for rapidly detecting internal generator phase-to-phase or phase-to-ground faults. After the detection of this fault the generator is quickly removed from service to limit the extent of the damage. The EGR-5000 uses a dual slope percentage differential scheme; advanced CT saturation algorithms maintain immunity against external disturbances and ensures the fault is internal to the generator before triggering it to trip.

Ground Differential Protection

In low resistance grounded generators, ground protection may be provided by the 87GD differential, depending on the fault level and the differential relay sensitivity. Higher sensitivity and fast operation for ground faults may be obtained by an additional zero-sequence differential.

Directional Overcurrent Protection

The EGR-5000 generation protection relay provides complete three-phase and ground directional overcurrent protection. There are 14 independent ground overcurrent elements. The ground elements "X" use the independently measured ground (or neutral) current from a separate current-sensing input. The ground elements "R" uses a calculated 3I₀ residual current obtained from the sum of the three-phase currents. This calculated current could be

used for either the neutral or ground current in a three-phase, four-wire system. Each of the phase and ground overcurrent elements can be selected to operate based on fundamental or RMS current.

Phase direction is a function used to supervise all phase current elements (50, 51). A quadrature voltage is compared to a corresponding phase current to establish the direction of the fault. This function is selectable to operate in the forward, reverse or both directions.

Ground direction is used to supervise ground current elements and is accomplished by using ground, negative sequence or residual currents supervised by zero, negative or positive sequence voltages or ground current. This function is selectable to operate in forward, reverse or both directions.

Voltage Restrained Overcurrent

Voltage restraint reduces the overcurrent pickup level (51P[2], 51P[3]), to protect the distribution system components against excessive damage and to prevent the generator and its auxiliaries from exceeding their thermal limitations. This modification of the pickup overcurrent level is compared to the corresponding phase input voltage. The EGR-5000 uses the simple linear model below to determine the effective pickup value.

Sync Check

The sync-check function is provided for double-ended power source applications. The sync-check monitors voltage magnitude, phase angle and slip frequency between the bus and line. It also incorporates breaker close time, dead bus dead line, dead bus live line and live bus live line features.

Reverse Power

Reverse power provides control for power flowing through a generator. There are three elements to be configured: operate in forward or reverse; or, under or over power conditions. Reverse power is typically applied to prevent generator motoring that can cause damage to the prime mover; while under power is generally applied to load loss and prevent an overspeed condition that could damage the prime mover.

Reverse VARs

Reverse vars can be used to detect loss of excitation in synchronous machines. There are three elements to be configured: operate in forward or reverse; or, under or over vars conditions.

Inverse Time Characteristics

There are 11 user-selectable inverse-time overcurrent curve characteristics.

The user can select from the ANSI, IEC or thermal curve families and can select instantaneous or time delay reset characteristics.

Breaker Failure

The EGR-5000 generator protection relay includes a breaker failure (50BF, 62BF) function that can be initiated from either an internal or external trip signal. This is an independent element that can be used to operate a lockout relay or trip an upstream breaker. The timer must be longer than the breaker operating time and the protective function reset times.

Voltage Protection

The EGR-5000 generator protection relay has four voltage-input circuits. There is a three-phase set designated as Main Voltage (M) and a single-phase voltage circuit designated as Auxiliary Voltage (A). Both include undervoltage (27) and overvoltage (59) protection. The three-phase voltage protection can be set to operate on a single-phase, two out of three phases, or all three-phase logic. The Main VTs also provide phase voltage unbalance/reversal (47 negative sequence) protection. Each element has an independent threshold set point and adjustable time delay.

100% Ground Stator Protection

In high impedance grounded generators, ground fault protection is provided by the detection of voltage in the neutral of the generator by an overvoltage element (59N) connected to the secondary of the distribution grounding transformer, this overvoltage element has to be desensitized for 3rd harmonic voltages normally present in the generator. Under normal conditions there is no voltage across the secondary of the grounded transformer, when one of the phases goes to ground, voltage appears across the resistor and the overvoltage element operates, indicating a ground conductor. However, the overvoltage element technique described above will protect around 90 percent to 95 percent of the winding. The last 5–10 percent is protected by detecting the decayed of the 3rd harmonic voltage using a undervoltage element (27TN) tuned to the 3rd harmonic voltage. In the EGR-5000 we can provide 100% stator ground protection by measuring the zero sequence voltage through the 4th voltage input, and combining the 59N and 27A elements. The 27A element has to be programmed to operate for 3rd harmonic zero sequence voltages.

Flexible Phase Rotation

The EGR-5000 generator protection relay can be applied on either an A-B-C or A-C-B phase rotation. A user setting permits correct operation and indication of the actual system configuration.

Frequency Protection

Operation of generators at off-nominal frequencies can have extremely detrimental effects on both the generator itself and the associated prime mover, in particular with steam turbine generators operating below normal frequency. The EGR-5000 relay provides six frequency elements than can be used to detect under/over frequency, rate of change, and a vector surge (decoupling of two systems) protection on the Main VT inputs. Each element has an independent threshold set point and adjustable time delay.

Inadvertent Energization

If a generator is inadvertently brought on line with the power system, without being up to speed and synchronized, or it is at standstill when the breaker is closed severe damage could occur. The generator will act as an induction motor and very high currents will be induced in the stator and rotor components, resulting in rapid overheating and damage.

Negative Sequence Protection

Negative sequence overcurrent protection prevents the generators from rotor overheating damage. Unbalanced loads, fault conditions or open phasing will produce a negative sequence current to flow. The unbalanced currents induce double system frequency currents in the rotor, which quickly causes rotor overheating. Serious damage will occur to the generator if the unbalance is allowed to persist. The EGR-5000 provides a negative sequence definite time overcurrent element and a negative sequence timed over current tripping element to ensure the generator stays within it's short time and continuous negative sequence current rated limits.

Overexcitation Protection

Generator overexcitation occurs when the ratio of voltage versus frequency is too high, and the rotor iron saturates due to high flux density. High flux density results in stray flux in components not designed to carry it, which in turn causes overheating and can potentially damage the generator. This protection is provided through a Volts/Hertz function with a programmable inverse time characteristic.

Loss of Excitation

Loss of field protection or loss of excitation is used to avoid unstable operation, potential loss of synchronism, and possible damage to synchronous generators. When a synchronous generator loses its field, the generator can continue to generate power as an induction generator, provided that it can obtain its excitation from the other machines on the system. During this condition, the rotor will quickly overheat due to the slip frequency currents induced in it. Loss of excitation in one machine could jeopardize the operation of other machines beyond their capability, and also the stability of the entire system. The EGR-5000 supports the two typical distance relaying schemes used for detecting the loss excitation. The two schemes differ mainly in that scheme 1 uses a negative offset mho element and scheme 2 uses a positive offset mho element with directional unit supervision.

Maintenance Mode

The Maintenance Mode can improve safety by providing a simple and reliable method to reduce fault clearing time and lower incident energy levels at energized panels. The Maintenance Mode allows the user to switch to more sensitive settings via a password protected soft key, communication or via a digital Input while maintenance work is being performed at an energized panel or device. The more sensitive settings provide greater security for maintenance personnel and helps reduce the possibility of injury.

Features, Benefits and Functions

Protection Features

- Dual-slope percentage restrained phase current differential (87)
- Unrestrained phase current differential (87H)
- Restricted ground fault/ Ground Differential (87GD)
- Unrestrained Restricted ground fault/Ground Differential (87GDH)
- Thermal protection (49/51)
- Phase overcurrent elements:
 - Three instantaneous elements with timers (50P[1], 50P[2] and 50P[3])
 - Three inverse time overcurrent elements (51P[1], 51P[2] and 51P[3])
- 11 standard curves
- Instantaneous or time delay reset
- Voltage restraint (51P[2] and 51P[3])
- Directional control (all elements)
- Ground overcurrent elements:
 - Two instantaneous measured elements with timers (50X[1] and 50X[2])
 - Two instantaneous calculated elements with timers (50R[1] and 50R[2])
 - Two inverse time overcurrent measured elements (51X[1] and 51X[2])
 - Two inverse time overcurrent calculated elements (51R[1] and 51R[2])
- 11 standard curves
- Instantaneous or time delay reset
- Directional control (all elements)
- Breaker failure (50BF)
- Phase unbalance negative sequence overcurrent (46[1], 46[2])
- Phase voltage unbalance and sequence protection (47[1], 47[2])
- Main three-phase under/ overvoltage (27M[1], 27M[2], 59M[1], 59M[2])
- Auxiliary single-phase under/overvoltage (27A[1], 27A[2], 59A[1], 59A[2])
- Ground fault overvoltage relay (59N[1], 59N[2])
- Six frequency elements that can be assigned to: over frequency, under frequency, rate of change, or vector surge (81[1], 81[2], 81[3], 81[4], 81[5], 81[6])
- Apparent and displacement power factor (55A[1], 55A[2], 55D[1], 55D[2])
- Forward and reverse watts (32[1], 32[2], 32[3])
- Forward and reverse VARs (32V[1], 32V[2], 32V[3])
- Overexcitation, volts-per-hertz (24[1], 24[2])
- 64S, 100% stator ground fault (27TN/ 59N)
- Generator unbalance (46G[1], 46G[2])
- Loss of excitation (40[1],40[2])
- Sync check (25)
- Inadvertent energization (50/27)
- Lockout (86)
- Loss of Potential-LOP
- Zone interlocking for bus protection (87B)
- Switch onto fault protection
- Cold load pickup

Metering Features

- Generator hours of operation
 - Phase Differential Current
 - Ground Differential Current
- Amperes: positive, negative and zero sequence
- Ampere demand
- Volts: positive, negative and zero sequence
- Phase angles
- Volt-amperes and VA demand
- Watts and kW demand
- kWh (forward, reverse, net)

- VARs and kVAR demand
- kVARh (lead, leg and net)
- Power factor
- Frequency
- Volts/Hertz
- 3rd Harmonic Voltage
- % THD V and I
- Magnitude THD V and I
- Minimum/maximum recording
- Sync values
- Trending (load profile over time)
- Temperature with remote URTD module

Monitoring Features

- Trip coil monitor
- Breaker wear
- Oscillography (7200 cycles total)
- Trip cause displays fault recorder data on HMI after fault event
- Fault data logs (up to 20 events)
- Sequence of events report (up to 300 events)
- Clock (1 ms time stamping)

Control Functions

- Breaker open/close
- Remote open/close
- Programmable I/O
- Programmable Logic
- Programmable LEDs
- Multiple setting groups
- Cold load pickup
- CT supervision

Communication Features

- Local HMI
- Password protected
- Addressable
- IRIG-B
- Local communication port:
 - RS-232
- Remote communication port:
 - RS-485
 - Ethernet port
- Protocols:
 - Modbus-RTU (optional)
 - Modbus-TCP (optional)
 - IEC-61850 (optional)
- Configuration software

Monitoring and Metering

Sequence of Events Records

The EGR-5000 generator protection relay records a maximum of 300 events associated with the relay. An event is classified as a change of state as detected by the relay. These include relay pickups, dropouts, trips, contact closure, alarms, setting changes and self-diagnostic failures. Each event is date and time stamped to a 1 ms resolution. The events are stored in a FIFO log in chronological order.

Trip Log

The EGR-5000 protection relay will store a maximum of 20 trip records in a FIFO trip log. Each trip record will be date and time stamped to a 1 ms resolution. The trip log record will include information on the type of fault, protection elements that operated, fault location and currents and voltages at the time of the fault.

PowerPort-E

PowerPort-E is the software program used to configure off-line protection setting files for all E-Series relay models. PowerPort-E is also used for viewing measured values of

the relays in real-time, uploading/downloading setting files, and retrieving event log and waveform records.

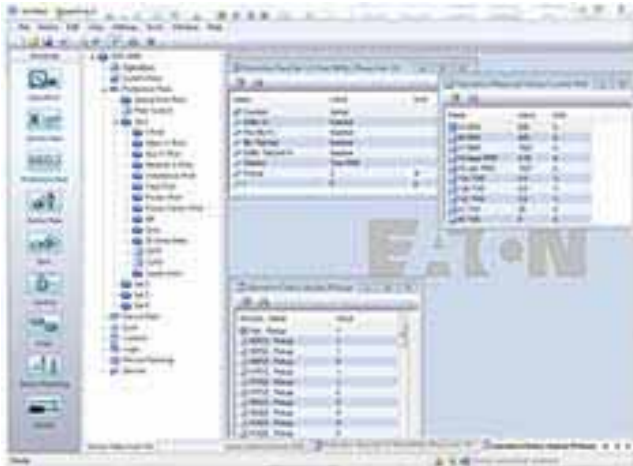

Waveform Capture (Quality Manager)

The EGR-5000 relay provides oscillographic recording capabilities. The relay will record all measured signals along with the binary signals of pickup, trip, internal logic, and contact inputs. The EGR-5000 can record up to 7200 cycles of data. The number of records is proportional to the programmed size of each record; the maximum size per record is 600 cycles.

The waveform capture is initiated by up to 8 different triggers (i.e., trip/alarm events) or manually via communications or the HMI. PowerPort-E setting software is used to retrieve the records. Quality Manager is a separate software program downloaded with PowerPort-E used for analyzing the waveform and trending files retrieved from the relay.

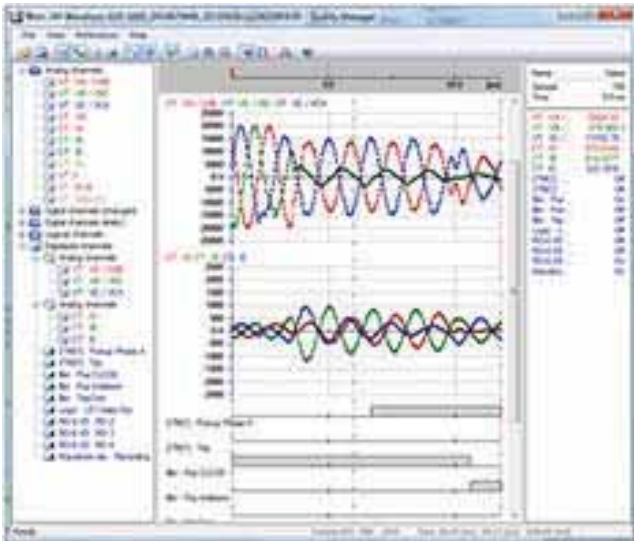

Integral User Interface

The front panel user interface has a 128 x 64 pixel LCD display with background illumination for wide angle viewing in all light conditions. 17 programmable LEDs provide quick and easy visual display of power on, mode of operation, alarm and trip indication. Soft keys are provided for operation mode selection, scrolling through data and settings. In addition, the relay settings and test functions are password protected.

Load Profiling/Trending

The EGR-5000 relay automatically records selected quantities into non-volatile memory every 5, 10, 15, 30 or 60 minutes, depending on the trending report setting.

Programmable I/O

The EGR-5000 generator protection relay provides heavy-duty, trip-rated, 2NO and 6 Form C contacts. Two isolated inputs can be used for monitoring the trip circuit. One Form C contact is dedicated to the relay failure alarm function and is operated in a normally energized (failsafe) mode. There are up to 16 user-configurable discrete inputs that accept a wet contact and can operate through a wide range of power. Each input and output is user-programmable for maximum application flexibility.

The EGR-5000 also offers two optional analog inputs and two optional analog outputs. The analog inputs are available for providing protection and monitoring of generator bearing vibration. The analog inputs are field programmable to measure transducer signals that operate over a range of 0 to 20 mA, 4 to 20 mA, or 1 to 10 V. The two optional analog outputs can be used for signaling the value of measured analog quantities to external process control devices such as PLCs.

They can be programmed to operate over a 0 to 20 mA, 4–20 mA, or 1 to 10 V range. The analog outputs can be configured to signal a representation of most analog quantities measured by the EGR-5000 including, current, voltages, and RTD temperature.

Programmable Logic

The EGR-5000 generator protection relay provides logic gates and timers that the user can customize for special or unique applications. Each gate can be assigned a logic function of either AND, OR, NAND or NOR. Each gate can have a maximum of four input signals and each input signal can be required to be a NOT. Input signals can be external inputs received via the binary inputs or internal values associated with the protection, alarm or metering set points. Each gate has a unique output assignment and designation that can be used as the input to another gate. There are 24 independent timers that have adjustable pickup and dropout delay settings.

Standards and Certifications

Approvals

- UL listed file: E217753

Design Standards

- Generic Standard:
 - EN 61000-6-2
 - EN 61000-6-3
- Product Standard:
 - IEC 60255-6
 - EN 50178
 - UL 508 (Industrial Control Equipment)
 - CSA C22.2 No. 14-95 (Industrial Control Equipment)
 - ANSI C37.90



9.3

Metering Devices, Protective Relays, Software and Connectivity

Protective Relays

Catalog Number Selection

The catalog number identification chart defines the electrical characteristics and operation features included in the EGR-5000. For example, if the catalog number is EGR-5000-2A0BA1, the device would have the following:

EGR-5000

(A)–16 DI, 9 Outputs, Removable Terminals, Zone Interlocking, URTD Interface

(0)–5 A / 1 A Phase and Ground CTs, Power Supply Range: 19–300 Vdc, 40–250 Vac

(B)–Modbus-RTU (RS-485)

(A)–Without conformal coating

(1)–Projection panel mount

EGR-5000 Eaton Motor Relay

EGR-5000-2A 0 B A 1

9

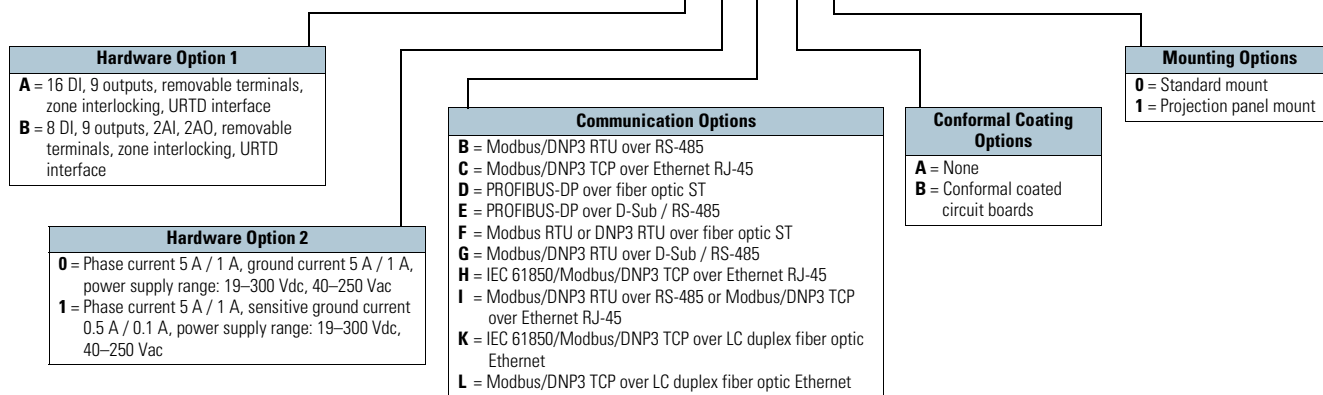

Accessories

Standard Accessories EGR-5000

Description	Catalog Number
UNVL RTD Mod with Modbus-RTU 48–240 Vac/48–250 Vdc	URTDII-01 ^①
UNVL RTD Mod with Modbus-RTU 24–48 Vdc	URTDII-02 ^①
E-Series RS-232 Null Modem Cable	66B2214G01
E-Series USB to RS-232 Converter	66B2214G02
E-Series RS-232 Cable and USB to RS-232 Converter	66B2214G03

Note

^① See URTD section for fiber optic cables required to communicate to the EGR-5000.

Technical Data and Specifications

Climatic Environmental Conditions

- Storage temperature: -30 °C to +70 °C (-22 °F to +158 °F)
- Operating temperature: -20 °C to +60 °C (-4 °F to +140 °F)
- Permissible humidity at ann. average: <75% rel. (on 56d up to 95% rel.)
- Permissible installation altitude:
 - <2,000 m (6,561.67 ft) above sea level
 - If 4,000 m (13,123.35 ft) altitude applies, a changed classification of the operating and test voltages may be necessary

Degree of Protection EN 60529

- HMI front panel with seal: IP54
- Rear side terminals: IP20

Routine Test

- Insulation test acc. to IEC 60255-5: All tests to be carried out against ground and other input and output circuits
- Aux. voltage supply, digital inputs, current
 - Measuring inputs, signal relay outputs: - 2.5 kV (eff.) / 50 Hz
- Voltage measuring inputs: 3.0 kV (eff.) / 50 Hz
- All wire-bound communication interfaces: 1.5 kV DC
- Insulation test acc to IEC60255-5: All tests to be carried out against ground and other input and output circuits

Housing

- Housing B2: height / width 183 mm (7.205 in) / 212.7 mm (8.374 in)
- Housing depth (incl. terminals): 208 mm (8.189 in)
- Material, housing: aluminum extruded section
- Material, front panel: aluminum/foil front
- Mounting position: horizontal (±45° around the X-axis must be permitted)
- Weight: Approx. 4.2 kg (9.259 lb)

Current and Ground Current Measurement

- Nominal currents: 1 A / 5 A
- Max. measuring range:
 - Up to 40 x I_n (phase currents)
 - Up to 25 x I_n (ground current standard)
 - Up to 2.5 x I_n (ground current sensitive)
- Continuous loading capacity: 4 x I_n / continuously
- Overcurrent proof:
 - 30 x I_n / 10 s
 - 100 x I_n / 1 s
 - 250 x I_n / 10 ms (1 half-wave)
- Power consumption:
 - Phase current inputs
 - At I_n = 1 A S = 0.15 MVA
 - At I_n = 5 A S = 0.15 MVA
 - Ground current input
 - At I_n = 1 A S = 0.35 MVA
 - At I_n = 5 A S = 0.35 MVA
- Frequency range: 50 Hz / 60 Hz ±10%
- Terminals: screw-type terminals with integrated short-circuiters (contacts)

• Connection cross sections:

- 1 x or 2 x 2.5 mm² (2 x AWG 14) with wire end ferrule
- 1 x or 2 x 4.0 mm² (2 x AWG 12) with ring cable sleeve or cable sleeve
- 1 x or 2 x 6 mm² (2 x AWG 10) with ring cable sleeve or cable sleeve
- The current measuring board's terminal blocks may be used as with 2 (double) conductors AWG 10,12,14 otherwise with single conductors only

Plug-in Connector with Integrated Short-Circuiter (Conventional Current Inputs)

- Nominal Current: 1 A and 5 A
- Continuous loading capacity: 4 x I_n / continuously
- Overcurrent withstand:
 - 30 x I_n / 10 s
 - 100 x I_n / 1 s
 - 250 x I_n / 10 ms (1 half-wave)
- Screws: M4, captive type acc. to VDEW
- Connection cross sections:
 - 1 x or 2 x 2.5 mm² (2 x AWG 14) with wire end ferrule
 - 1 x or 2 x 4.0 mm² (2 x AWG 12) with ring cable sleeve or cable sleeve
 - 1 x or 2 x 6 mm² (2 x AWG 10) with ring cable sleeve or cable sleeve
 - The current measuring board's terminal blocks may be used as with 2 (double) conductors AWG 10,12,14 otherwise with single conductors only

Voltage and Residual Voltage Measurement

- Nominal voltages: 100 V / 110 V / 230 V / 400 V (can be configured)
- Max. measuring range: 2 x nominal voltage
- Continuous loading capacity: 2 x nominal voltage (800 Vac)
- Power consumption:
 - at V_n = 100 V S = 0.1 MVA
 - at V_n = 110 V S = 0.1 MVA
 - at V_n = 230 V S = 0.4 MVA
 - at V_n = 400 V S = 1.0 MVA
- Frequency range: 50 Hz or 60 Hz ±10%
- Terminals: screw-type terminals

Frequency Measurement

- Nominal frequencies: 50 Hz / 60 Hz

Voltage Supply

- Aux. voltage: 24-270 Vdc / 48-230 Vac (-20/+10%)
- Buffer time in case of supply failure:
 - ≥50 ms at minimal aux. voltage
 - Interrupted communication is permitted
- Max. permissible making current:
 - 18 A peak value for <0.25 ms
 - 12 A peak value for <1 ms
- The voltage supply must be protected by a fuse of:
 - 2.5 A time-lag miniature fuse 5 x 20 mm (approx. 0.2 x 0.8 in) according to IEC 60127
 - 3.5 A time-lag miniature fuse 6.3 x 32 mm (approx. 0.25 x 1.25 in) according to UL 248-14

Power Consumption

- Power supply range: 24–270 Vdc
 - Power consumption in idle mode—7 W
 - Maximum power consumption—13 W
- Power supply range: 48–230 Vac (for frequencies of 40–70 Hz)
 - Power consumption in idle mode—7 VA
 - Maximum power consumption—13 VA

Display

- Display type: LCD with LED background illumination
- Resolution—graphics display: 128 x 64 pixel

LED

- LED type: two colored: red/green
- Number of LEDs, Housing B2: 15

Front Interface RS-232

- Baud rates: 115,200 baud
- Handshake: RTS and CTS
- Connection: 9-pole D-Sub plug

Real Time Clock

- Running reserve of the real time clock: 1 year min.

Digital Inputs

- Max. input voltage: 300 Vdc / 259 Vac
- Input current: <4 mA
- Reaction time: <20 ms
- Fallback time: <30 ms

(Safe state of the digital inputs)

- Switching thresholds: $U_n = 24 \text{ Vdc}, 48 \text{ Vdc}, 60 \text{ Vdc}, 110 \text{ Vac} / \text{Vdc}, 230 \text{ Vac} / \text{Vdc}$
 - $U_n = 24 \text{ Vdc}$
 - Switching threshold 1 ON: Min. 19.2 Vd
 - Switching threshold 1 OFF: Max. 9.6 Vdc
 - $U_n = 48 \text{ V} / 60 \text{ Vdc}$
 - Switching threshold 2 ON: Min. 42.6 Vdc
 - Switching threshold 2 OFF: Max. 21.3 Vdc
 - $U_n = 110 / 120 \text{ Vac} / \text{Vdc}$
 - Switching threshold 3 ON: Min. 88.0 Vdc / 88.0 Vac
 - Switching threshold 3 OFF: Max. 44.0 Vdc / 44.0 Vac
 - $U_n = 230 / 240 \text{ Vac} / \text{Vdc}$
 - Switching threshold 4 ON: Min. 184 Vdc / 184 Vac
 - Switching threshold 4 OFF: Max. 92 Vdc / 92 Vac
- Terminals: screw-type terminal

Relay Outputs

- Continuous current: 5 A AC/DC
- Max. make current:
 - 25 A AC / 25 A DC up to 30 V for 4 s
 - 30 A / 230 Vac according to ANSI IEEE Std C37.90-2005
 - 30 A / 250 Vdc according to ANSI IEEE Std C37.90-2005
- Max. breaking current:
 - 5 A AC up to 250 Vac
 - 5 A DC up to 30 V (resistive)
 - 0.3 A DC at 300 V
- Max. switching voltage: 250 Vac / 250 Vdc
- Switching capacity: 1250 VA
- Contact type: Form C or normally open contact
- Terminals: screw-type terminals

Supervision Contact (SC)

- Continuous current: 5 A AC/DC
- Max. switch-on current: 15 A AC / 15 A DC up to 30 V for 4 s
- Max. breaking current:
 - 5 A AC up to 250 Vac
 - 5 A DC up to 30 Vdc
 - 0.4 A at 125 Vdc
- Contact type: 1 Form C contact
- Terminals: screw-type terminals

Time Synchronization IRIG-B00X

- Nominal input voltage: 5 V
- Connection: screw-type terminals (twisted pair)

Zone interlocking

Note: Only for zone interlock tripping outputs (zone interlock, semiconductor output): 5 Vdc, <2 mA for connection to electronic inputs only.

- Zone Out:
 - Output voltage (high) 4.75 to 5.25 Vdc
 - Output voltage (low) 0.0 to +0.5 Vdc
- Zone In:
 - Nominal input voltage +5 Vdc
 - Max. input voltage +5.5 Vdc
 - Switching threshold ON min. 4.0 Vdc
 - Switching threshold OFF max. 1.5 Vdc
 - Galvanic isolation 2.5 kV AC (to ground and other IO)
 - Connection: screw-type terminals (twisted pair)

RS-485

- Master/slave: slave
- Connection: six screw-clamping terminals RM 3.5 mm (138 MIL) (terminating resistors internal)

Note: The RS-485 interface is realized via terminals. The communication cable has to be shielded. The shielding has to be fixed at the screw that is marked with the ground symbol (rear side of the device).

Wiring Diagrams

Typical AC Connections—High Impedance Grounded Generator with Phase Differential Protection, Wye VTs, Zero Sequence Ground Protection, and Either Synch-check or 100% Stator Ground Fault Protection

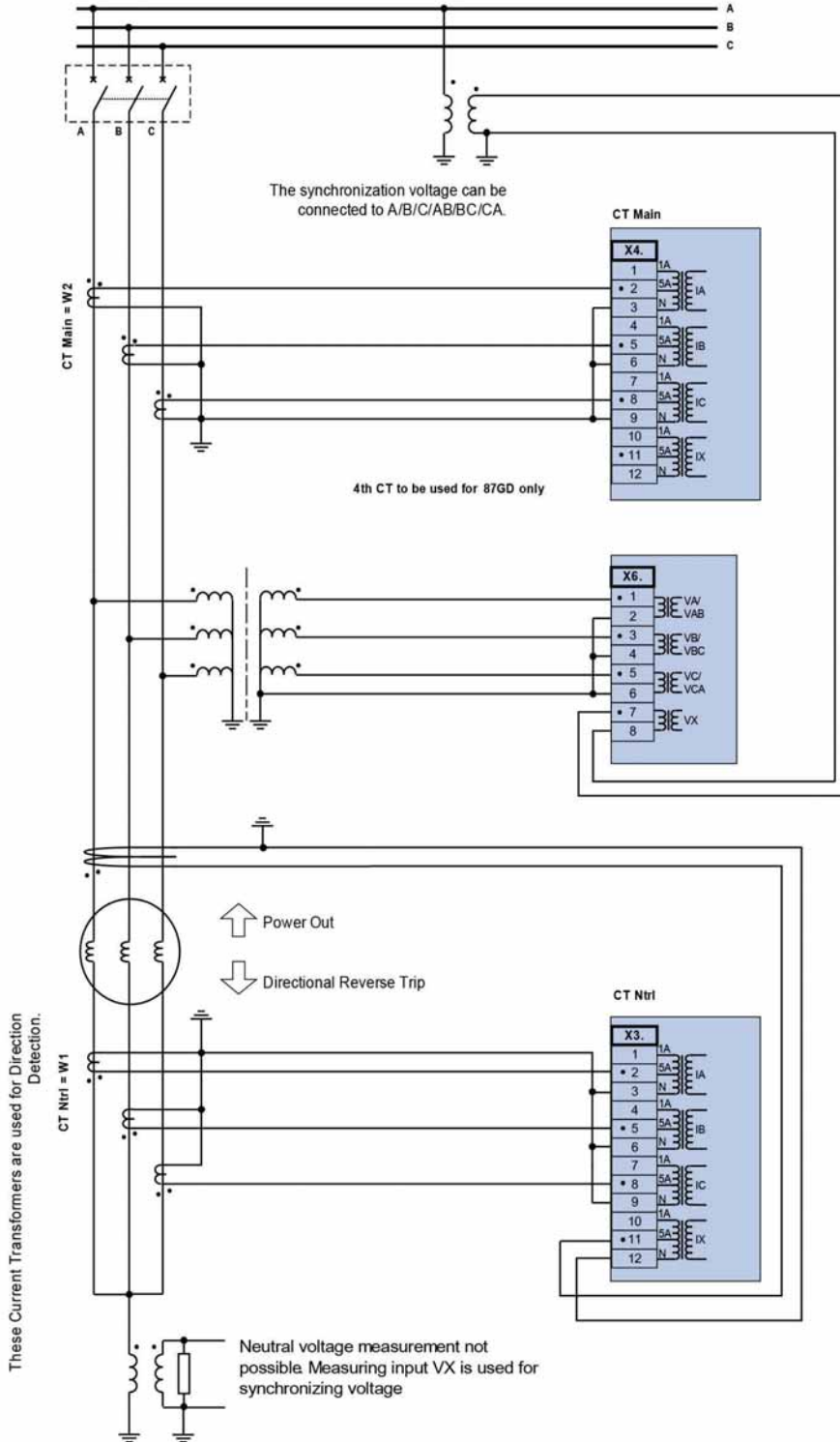

Typical One-Line Diagram

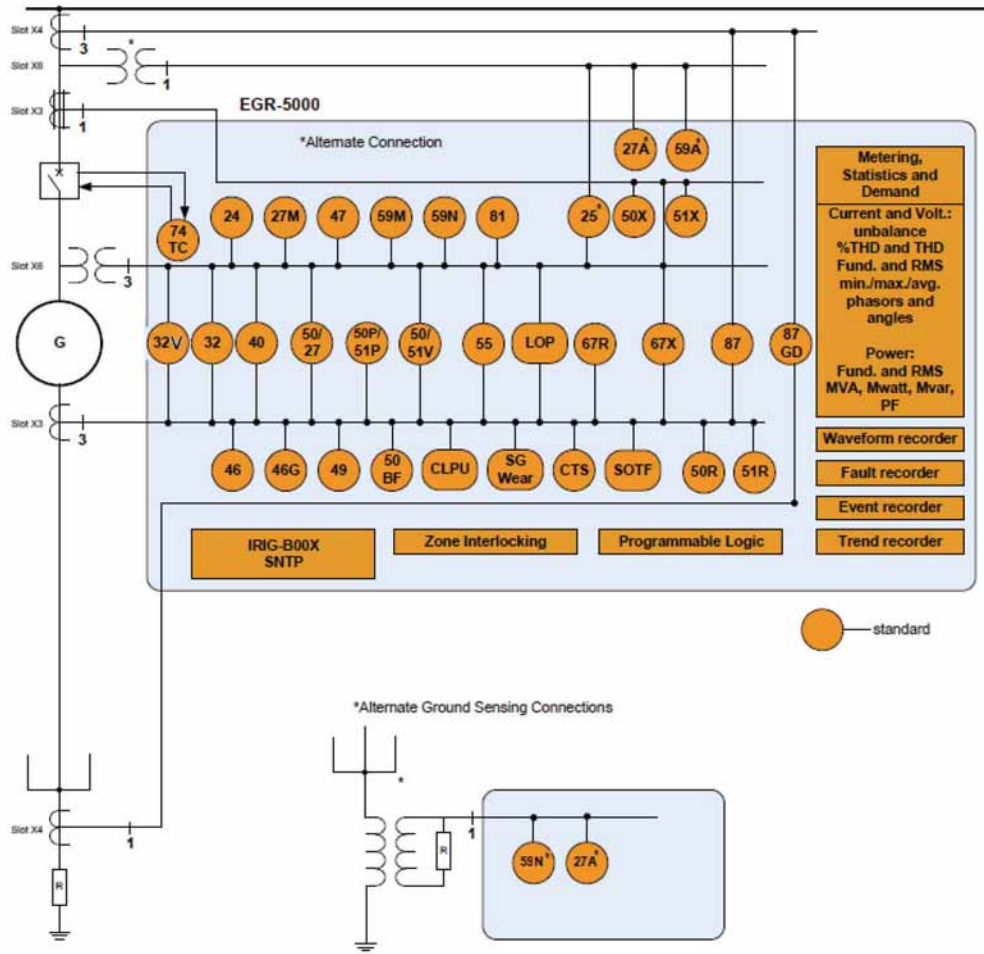

Typical Control Diagram

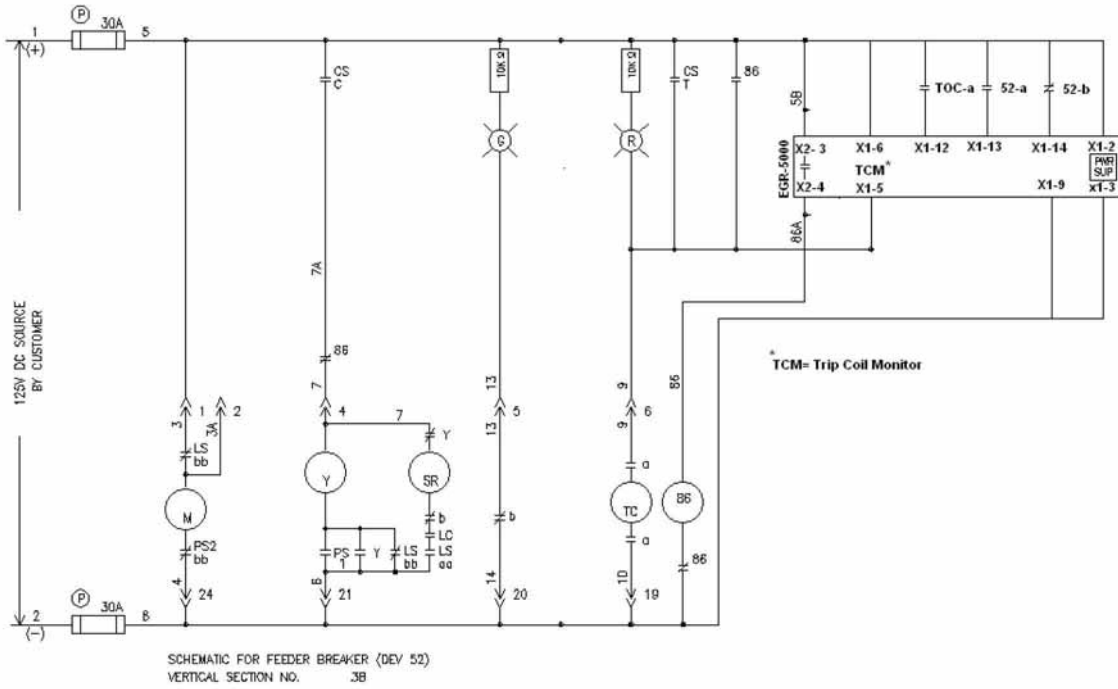

Dimensions

Approximate Dimensions in Inches (mm)

Drilling Plan

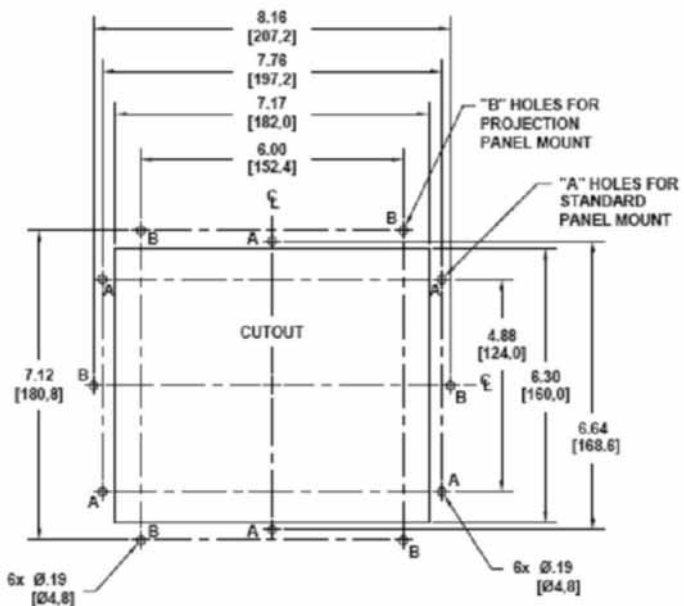

Projection Mount Front and Side Views

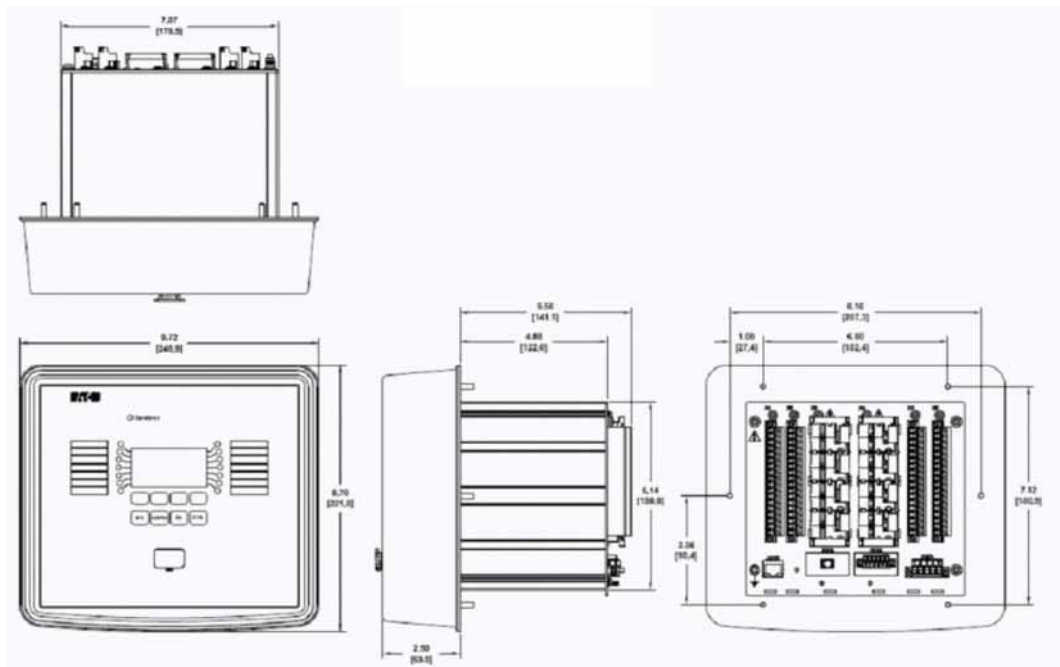

Approximate Dimensions in Inches (mm)

Standard Mount Front and Side Views

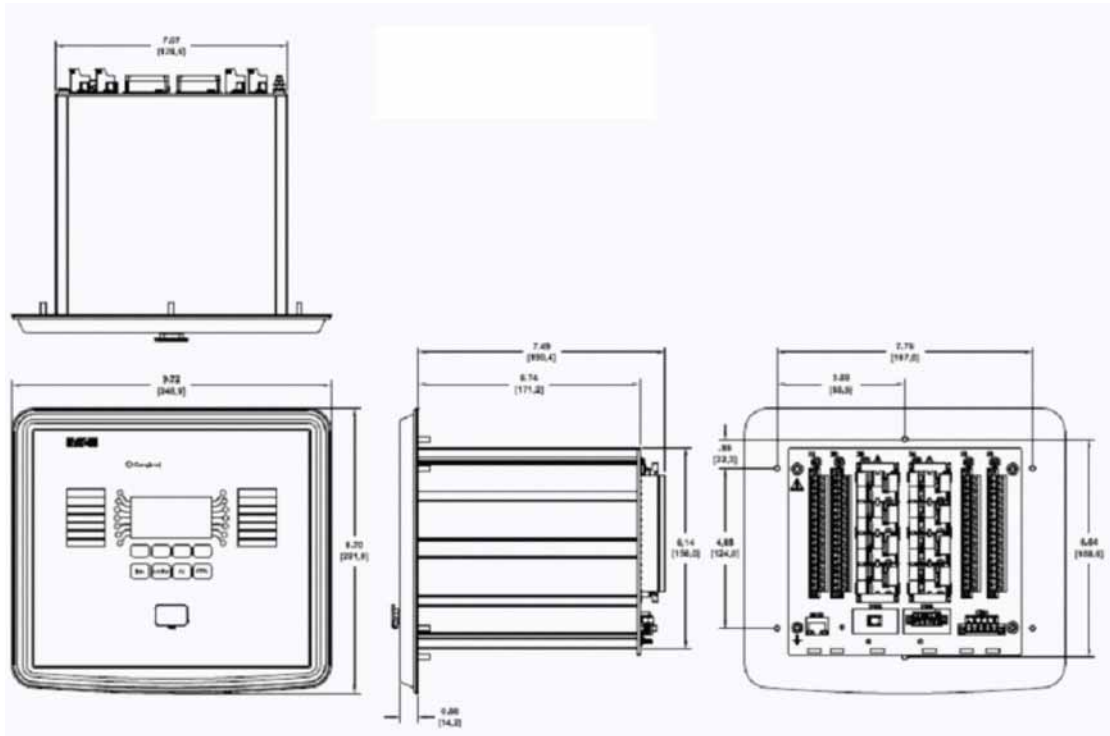

Ground Fault Relay



Ground Fault Relay

Product Description

A Type GFR ground fault protection system, when properly installed on a grounded electrical system, will sense phase-to-ground fault currents. When the level of fault current is in excess of the pre-selected current pickup and time delay settings, the GFR relay will initiate a trip action of a disconnect device, which will open the faulted circuit and clear the fault.

The GFR devices are UL Class 1 devices designed to protect electrical equipment against extensive damage from arcing ground faults.

A basic Type GFR ground fault protection system consists of a ground fault relay, a ground fault current sensor and a disconnect device equipped with a shunt trip device. This disconnect device can be a molded case circuit breaker, a power circuit breaker, a bolted pressure switch or other fusible disconnect device, suitable for application with UL Class 1 Ground Fault Sensing and Relaying equipment.

Contents

Description

	<i>Page</i>
Product Selection Guide	V3-T9-117
Digitrip 3000	V3-T9-123
EDR-3000 Feeder Protection	V3-T9-133
EDR-5000 Distribution Protection Relay	V3-T9-142
FP-5000 Feeder Protection	V3-T9-155
MP-3000 Motor Protection	V3-T9-163
MP-4000 Motor Protection	V3-T9-173
EMR-3000 Motor Protection Relay	V3-T9-179
EMR-4000 Motor Protection Relay	V3-T9-191
EMR-5000 Motor Protection Relay	V3-T9-204
ETR-4000 Transformer Protection Relay	V3-T9-216
ETR-5000 Transformer Protection Relay	V3-T9-228
EGR-5000 Generation Protection Relay	V3-T9-241
Ground Fault Relay	
Universal RTD Module	V3-T9-257

Standards and Certifications

Eaton's GFR ground fault relays, current sensors, test panels and accessory devices are UL listed by Underwriters Laboratories in accordance with their standard for Ground Fault Sensing and Relaying Equipment, UL 1053, under File No. E48381.

Note: Relays are also listed with CSA under File No. 43357.



Product Selection

Each installation requires:

- One relay unit (select trip ampere as required)
- One current sensor (select configuration required)
- One circuit breaker or disconnect device with shunt trip, or a shunt trip attachment for mounting in existing breaker
- Test panel (optional)

GFR Relay



GFR Relay

GFR Relay Types	Ground Fault Pickup Amperes		
	1–12 Catalog Number ①	5–60 Catalog Number ①	100–1200 Catalog Number ①
For 120 Volt 50/60 Hz Control			
Electrical reset with zone interlocking	GFR12EI	GFR60EI	GFR1200EI
Electrical reset without zone interlocking	GFR12E	GFR60E	GFR1200E
Mechanical reset with zone interlocking	GFR12MI	GFR60MI	GFR1200MI
Mechanical reset without zone interlocking	GFR12M	GFR60M	GFR1200M
For 120 Vdc Control			
Mechanical reset without zone interlocking	—	—	GFR1200MD

Current Sensor

Description—Window Size in Inches (mm)	Catalog Number
Used with Relays Rated 1–12 Amperes	
5.50 (139.7) inside diameter	1283C45G01
Used with Relays Rated 5–60 Amperes	
2.50 (63.5) inside diameter	179C768G01
5.50 (139.7) inside diameter	1256C13G01
7.81 x 11.00 (198.4 x 279.4) rectangular ①	1257C88G04
3.31 x 24.94 (84.1 x 760.5) rectangular ①	1257C92G03
Used with Relays Rated 100–1200 Amperes	
2.50 (63.5) inside diameter	179C768G02
5.50 (139.7) inside diameter	1256C13G02
8.25 (209.6) inside diameter	179C767G02
7.81 x 11.00 (198.4 x 279.4) rectangular ①	1257C88G03
9.94 x 16.94 (252.5 x 430.3) rectangular ①	1257C90G02
9.94 x 23.94 (252.5 x 608.1) rectangular ①	1257C91G02
15.94 x 19.94 (404.9 x 506.4) rectangular ①	1257C89G02
3.31 x 24.94 (84.1 x 633.5) rectangular ①	1257C92G04
6.75 x 29.64 (171.5 x 752.9) rectangular ①	1255C39G03

Note

① Suitable for either surface or semi-flush mounting.

Options and Accessories

Test Panel (120 Vac)

Used to test the ground fault system, to give an indication the relay has tripped the breaker, and to reset the relay after tripping. These functions may be separately mounted pilot devices.

Note: When a mechanically reset relay is used with a test panel, both the relay and test panel must be reset following either a simulated ground fault test or actual ground fault. Not UL listed.

Ground Fault Warning Indicator

This is an accessory item for use with GFR relays with interlocking circuitry. At approximately 30–50% of the relay pickup setting, the indicator switches separate 120 Vac control power to a lamp or relay (not included) to give an indication of a ground fault. The indicator is rated 110/120 Vac 50/60 Hz for a maximum indicator load of 0.5 amperes.

Indicating Ammeter

The optional indicating ammeter connects to the sensor terminals through a momentary contact pushbutton, and will indicate (in amperes) any ground fault current flowing through the sensor. Kit includes the ammeter and pushbutton.

Not UL listed.

Shunt Trip Attachments

Use 120 Vac shunt trips.

Face Plate

Recommended when these relays are semi-flush mounted, to close the door cutout opening.

Options

Additional optional equipment can be added to the protection system to meet the requirements of the specifying engineer, including:

- Ground fault test panel
- Ground fault warning indicator relay
- Ground fault indicating ammeter

GFR relays are available with zone selective interlocking circuitry to interlock several relays within the same system. This allows the relay, which detects a ground fault, to instantly clear the fault by tripping the disconnect device. The relay simultaneously sends a signal to relay units “upstream” from the fault to time delay or to block their operation completely. Current sensors in various designs provide a range of “window” sizes to accommodate standard bus and cable arrangements.

Shunt trip attachments may be ordered for field mounting in Eaton’s molded case circuit breakers, or may be ordered factory installed in the breaker.

Optional Test Panel

Control	Test	Catalog Number
120 volt 50/60 Hz	120 volt 50/60 Hz	GFRTP

Ground Fault Warning Indicator

Description	Catalog Number
Manual reset	1234C67G01
Self-resetting	1234C67G02

Ammeter Kit

GFR System Used with	Kit Catalog Number
1–12 amperes	752B820G01
5–60 amperes	752B820G02
100–1200 amperes	752B820G03

Face Plate

Description	Catalog Number
Face plate	752B410G01

Technical Data and Specifications

GFR Relay

- Ground fault detection ranges:
 - 1–12 amperes
 - 5–60 amperes
 - 100–1200 amperes
- Output contacts:
 - 240 Vac, 50/60 Hz: 3 amperes
 - 120 Vac, 50/60 Hz: 6 amperes
 - 28 Vdc: 3 amperes
 - 125 Vdc: 0.5 amperes
- Control power requirements:
 - 120 V, 50/60 Hz: 0.125 amperes, or 125 Vdc (optional)

Current Sensor

- 600 V, 50/60 Hz maximum system voltage

Note

① One end removable for installation.

Instruction Leaflet 15321 available as a PDF at www.eaton.com (Go to Advanced Search and enter 15321).

Universal RTD Module



Contents

<i>Description</i>	<i>Page</i>
Product Selection Guide	V3-T9-117
Digitrip 3000	V3-T9-123
EDR-3000 Feeder Protection	V3-T9-133
EDR-5000 Distribution Protection Relay	V3-T9-142
FP-5000 Feeder Protection	V3-T9-155
MP-3000 Motor Protection	V3-T9-163
MP-4000 Motor Protection	V3-T9-173
EMR-3000 Motor Protection Relay	V3-T9-179
EMR-4000 Motor Protection Relay	V3-T9-191
EMR-5000 Motor Protection Relay	V3-T9-204
ETR-4000 Transformer Protection Relay	V3-T9-216
ETR-5000 Transformer Protection Relay	V3-T9-228
EGR-5000 Generation Protection Relay	V3-T9-241
Ground Fault Relay	V3-T9-254
Universal RTD Module	

Universal RTD Module

Product Description

- Electronic Resistance Temperature Detector (RTD) provides motor temperature interface for the MP-3000 Motor Protection Relay
- Monitors up to 11 RTDs consisting of six motor windings, two motor bearings, two load bearings and one auxiliary
- Works with 10 ohm copper, 100 ohm platinum, 100 ohm nickel and 120 ohm nickel type RTDs
- Include fiber optic and electrical communication interfaces to the MP-3000 Motor Protection Relay

Application Description

URTD can be used with MP-3000, MP-4000, EMR-3000, EMR-4000, EMR-5000, ETR-4000, ETR-5000, and EGR-5000.

Eaton’s URTD Module is most commonly used to provide motor temperature information to the MP-3000 Motor Protection Relay. The MP-3000 Motor Protection uses this information for monitoring, tripping and alarming. The MP-3000 Intel-I-Trip overload algorithm will adjust its trip characteristics based on the actual motor temperature reported by the URTD Module. This improves the protection by using an actual temperature value instead of the assumed NEMA Standard Ambient Temperature.

The URTD Module may be mounted close to the motor or at the protective relay.

Both electrical and fiber optic interface ports are provided to communicate temperature information to the MP-3000 relay. The electrical interface can transmit information using a three-conductor shielded cable with a maximum cable distance of 500 feet (152 m). The fiber optic link has a maximum distance of 400 feet (122 m).

The URTD Module may be used with the IQ-1000 and IQ-1000 II motor relays. It may also be applied as a standalone temperature monitoring device communicating, for example, transformer temperature information back to a remote computer or PLC. An optional PONI (Product Operated Network Interface) is required for standalone applications.

Features, Benefits and Functions

- Universal design works with any RTD type, simplifying installation and operation and reducing inventory
- Standalone design permits mounting the module close to the motor, reducing RTD wiring costs
- RTD diagnostics detects faulty RTDs and wiring, reducing unnecessary tripping and alarming

Product Selection

Universal RTD Module



Universal RTD Module

Description	Catalog Number
Universal RTD Module	URTD
48-240 Vac/48-250 Vdc power supply and Modbus-RTU communications	URTDII-01
24-48 Vdc and Modbus-RTU communications	URRDII-02

Options and Accessories

Additional Related Products from Eaton's Cutler-Hammer Series

Eaton provides fiber optic cables for connecting to the MP-3000 or IQ-1000 II Motor Protection Relays.

Fiber Optic Cables:

Length	Catalog Number
1	MPF0-1
5	MPF0-5
10	MPF0-10
25	MPF0-25
50	MPF0-50
75	MPF0-75
100	MPF0-100

Technical Data and Specifications

Universal RTD Module

Specifications	URTDII-01	URTDII-02
Input power requirements	48–240 Vac / 48–250 Vdc	24–48 Vdc
Frequency	50/60 Hz or DC	DC
Power consumption	3.5 W	1 W
Operating temperature	–20° to +55 °C (–4° to +131 °F)	–20° to +55 °C (–4° to +131 °F)
Storage temperature	–40° to +85 °C (–40° to +185 °F)	–40° to +85 °C (–40° to +185 °F)
Humidity	0 to 95% R.H. noncondensing	0 to 95% R.H. noncondensing
Altitude	2000 m	2000 m
Pollution degree	2	2
Installation category	I	I

Wiring Diagram

RTD Wiring (Three-Lead Type)

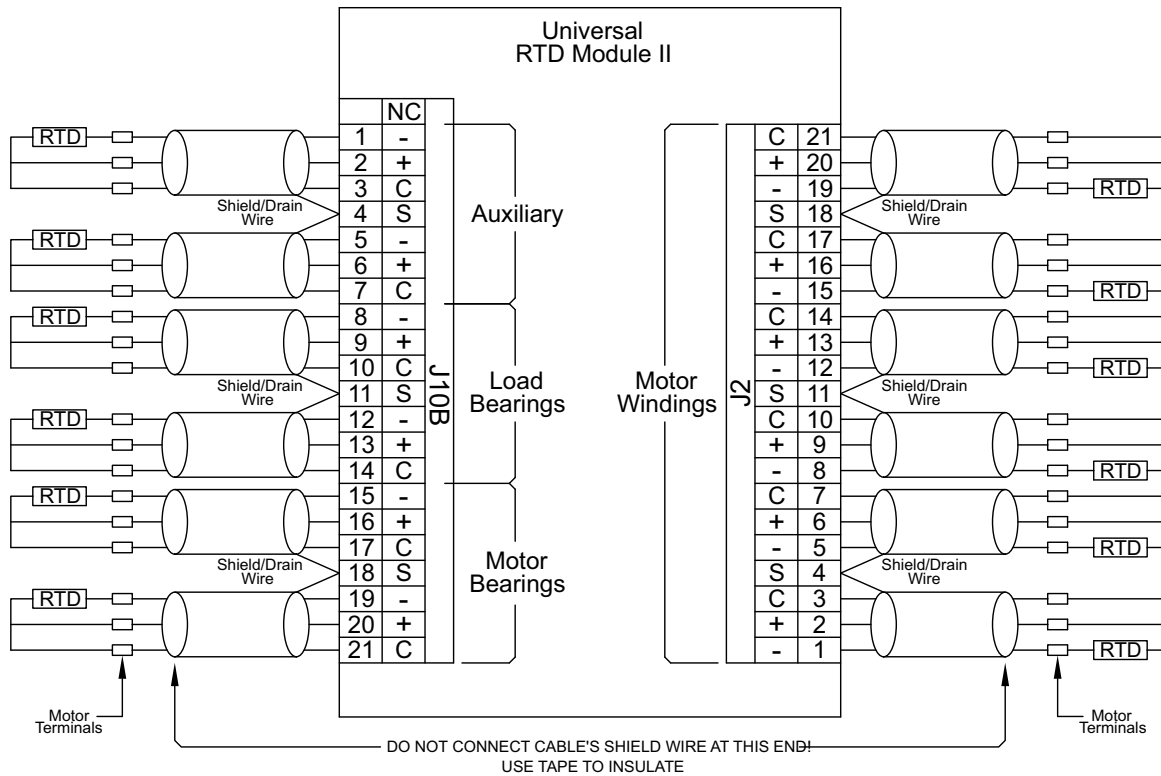

Note:

1. Each shielded cable conductor must be connected on the URTDII as shown.
2. Use of three-lead RTDs is recommended.
3. RTDs must not be grounded at the motor, and no common connections between RTDs should be made at the motor.
4. A suitable earth ground should be connected to J10B-4, J10B-11, J-10B-18, J2-4, J2-11, or J2-18. It is recommended that a ground connection is made to both sides of the unit.

Note

Showing a typical three-lead type RTD wiring connection.

Dimensions

Approximate Dimensions in Inches (mm)

Universal URTD Module

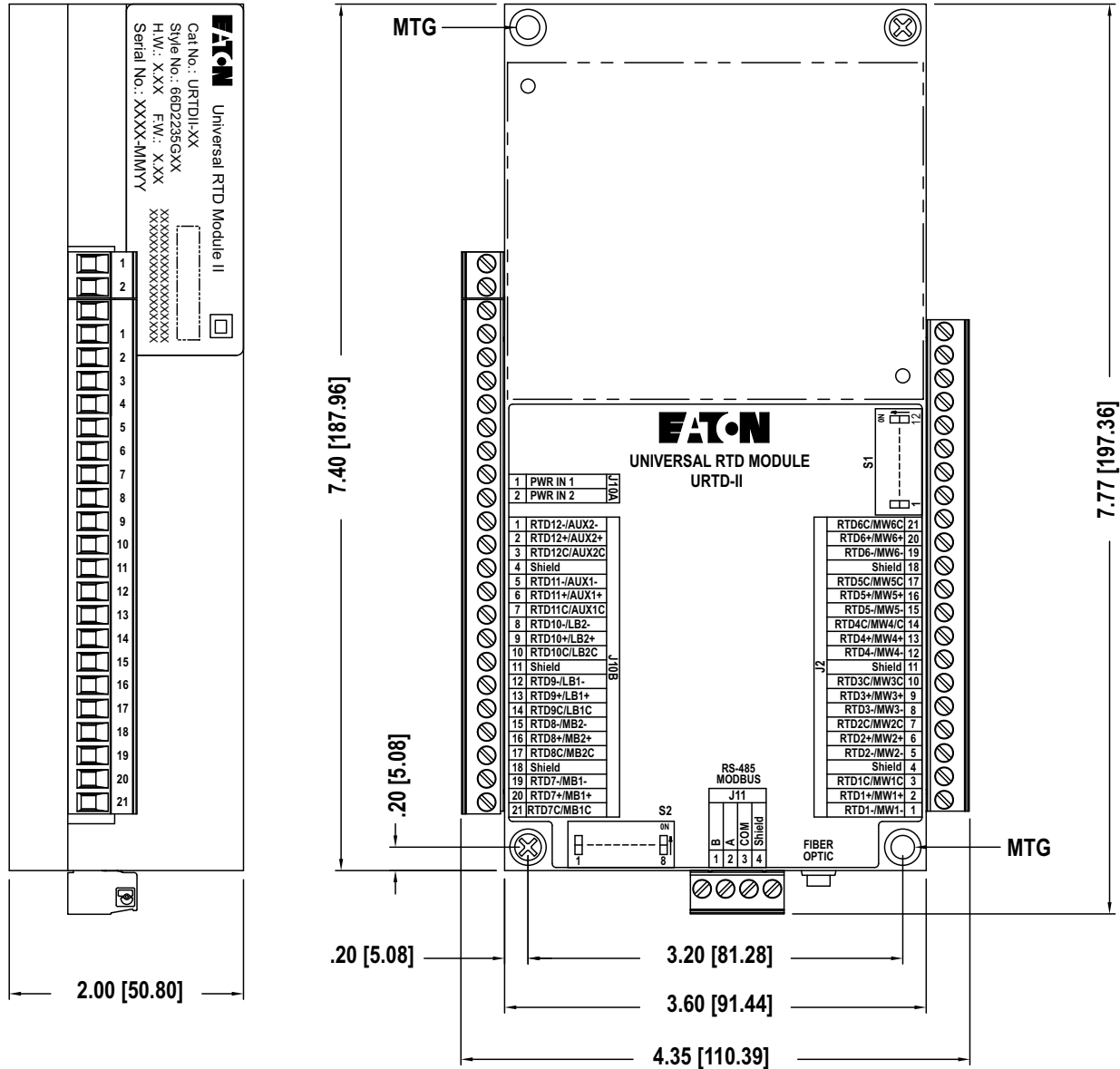

Note

Showing the URTD Module dimensions and terminal designations.

Power Xpert Gateway



Contents

Description	Page
Power Xpert Gateway	
Product Selection Guide	V3-T9-263
Product Description	V3-T9-262
Standards and Certifications	V3-T9-265
Product Selection	V3-T9-265
Technical Data and Specifications	V3-T9-266
Dimensions	V3-T9-269
Power Xpert Ethernet Switches	V3-T9-270
mMINT	V3-T9-274
IPONI	V3-T9-276
DPONI	V3-T9-277
MPONI	V3-T9-278
I/O Devices Digital Input Module (DIM)	V3-T9-279
Addressable Relay II	V3-T9-281
Breaker Interface Module II (BIM II)	V3-T9-283

Power Xpert Gateway

Product Overview

- Open communication architecture
 - Connects to both Eaton and third-party electrical equipment; communicates to INCOM™ and Modbus® RTU devices
 - Modbus TCP and BACnet/IP support facilitates integration with third-party monitoring solutions
 - Ethernet/Web-based support uses your existing network infrastructure, reducing costs
- Flexible and expandable solutions
 - Stand-alone or small systems benefit from comprehensive, on-board Web pages; no additional programming or software is necessary for virtually out-of-the-box, plug-and-play functionality
 - Larger systems, such as campus installations or power systems with remote locations can view multiple PXGs via Power Xpert Insight™ or a third-party monitoring system
 - Existing equipment can be connected to the PXG to reap the benefits of Power Xpert Architecture at minimal cost, without the need to upgrade
- Information at a glance
 - Using a standard Web browser, view the PXG's Web interfaces that include a Network tab, Alarms tab, individual device detail pop-outs and One Line graphics tab
 - Comprehensive, well-organized device Web pages present measured parameters such as current, voltage, power, energy, frequency, power factor and voltage THD, just to name a few
 - Combine with Power Xpert Insight for viewing multiple gateways and other power system equipment for more extensive energy monitoring and capacity analysis

Product Description

Through standard on-board Web pages, Power Xpert Insight, or third-party software, Eaton's Power Xpert Gateway (PXG) 900 allows you to closely monitor the performance of your power and energy efficiency with easily accessed, real-time, Web-enabled data. Eaton's PXG 900 provides a central point to connect devices to an Ethernet network. The gateway may be used as a standalone device to view one system or location, or it can be easily integrated into a large, multi-location system.

The PXG is our configurable data acquisition solution for facility equipment like switchgear, switchboards, motor control centers, etc. Power and energy data from the downstream devices are time stamped and stored in non-volatile memory. This interval data can be stored or updated to a destination of the user's choice through CSV. Data can also be accessed through any Web browser directly on the PXG. Users can move data into Power Xpert Insight v. 3.2 or higher, BMS, BAS, building dashboards, custom software applications, or virtually any Web interface.

Application Description

The Power Xpert® Gateway 900 (PXG 900) has been designed to be installed in electrical assemblies or systems—low and medium voltage switchgear, switchboards panelboards, transfer switches, and motor control centers to acquire and consolidate data available from components such as trip units, meters, relays, drives and I/O.

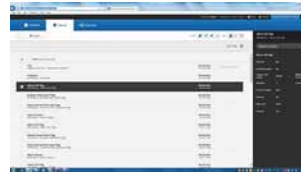
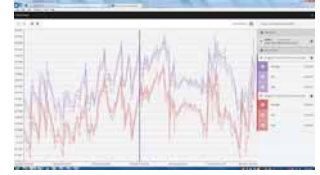
Power Xpert Gateway Screenshots**Network Tab****Device Details****Alarms Tab****Trend Viewer****One-Lines Tab**

Product Selection Guide

Data acquisition and Integration Table for Supported Devices

Supported Devices

Protocol

Family	Model	HTTP (Web Browser)	Power Xpert Insight	Modbus TCP (BMS and SCADA)	Pass-through INCOM (PowerNet)	SMTP (Email Client)	File Export (CSV File Format)	File export (COMTRADE File Format)	BACnet/IP
INCOM									
Accessory	BIM II	■	■	■	■	■	■		■
I/O	DIM	■	■	■	■	■	■		■
I/O	DIM-KYZ	■	■	■	■	■	■		■
Meter	IQ 220 / IQ 320	■	■	■	■	■	■		■
Meter	IQ 230 / IQ 330	■	■	■	■	■	■		■
Meter	IQ Analyzer (6000/6200)	■	■	■	■	■	■		■
Meter	IQ Analyzer (6400/6600)	■	■	■	■	■	■	■	■
Meter	IQ Data Plus II	■	■	■	■	■	■		■
Meter	IQ DP-4000	■	■	■	■	■	■		■
Meter	IQ Energy Sentinel	■	■	■	■	■	■		■
Meter	IQ Power Sentinel	■	■	■	■	■	■		■
Meter	IQMESII	■	■	■	■	■	■		■
Meter	PM3	■	■	■	■	■	■		■
Protection	Digitrip 520MC	■	■	■	■	■	■		■
Protection	Digitrip 810	■	■	■	■	■	■		■
Protection	Digitrip 910	■	■	■	■	■	■		■
Protection	Digitrip 1150/DT1150V	■	■	■	■	■	■	■	■
Protection	Digitrip 3000	■	■	■	■	■	■		■
Protection	Digitrip 3200	■	■	■	■	■	■		■
Protection	Digitrip MV	■	■	■	■	■	■		■
Protection	Digitrip OPTIM 550	■	■	■	■	■	■		■
Protection	Digitrip OPTIM 750	■	■	■	■	■	■		■
Protection	Digitrip OPTIM 1050	■	■	■	■	■	■		■
Protection	FP-4000	■	■	■	■	■	■	■	■
Protection	FP-5000	■	■	■	■	■	■	■	■
Protection	FP-6000	■	■	■	■	■	■	■	■
Protection	IQ 500	■	■	■	■	■	■		■
Protection	MP-3000	■	■	■	■	■	■		■
Protection	MP-4000	■	■	■	■	■	■		■
Protection	MPCV Relay	■	■	■	■	■	■		■
Protection	NRX520I	■	■	■	■	■	■		■
Protection	NRX1150I	■	■	■	■	■	■		■
Protection	TC50	■	■	■	■	■	■		■
Protection	TC100	■	■	■	■	■	■		■
Protection	Universal RTD	■	■	■	■	■	■		■
Transfer switch	ATC-400	■	■	■	■	■	■		■
Transfer switch	ATC-600	■	■	■	■	■	■		■
Transfer switch	ATC-800	■	■	■	■	■	■		■

Supported Devices, continued

Protocol

Family	Model	HTTP (Web Browser)	Power Xpert Insight	Modbus TCP (BMS and SCADA)	Pass-through INCOM (PowerNet)	SMTP (Email Client)	File Export (CSV File Format)	File export (COMTRADE File Format)	BACnet/IP
Modbus									
Drive	H-Max	■	■	■		■	■		■
Drive	M-Max	■	■	■		■	■		■
Drive	MVX9000	■	■	■		■	■		■
Drive	SVX9000	■	■	■		■	■		■
Meter	E30/E31A042 1 phase BCM	■	■	■		■	■		■
Meter	EM19_M	■	■	■		■	■		■
Meter	ION 7350	■	■	■		■	■		■
Meter	ION 7550	■	■	■		■	■		■
Meter	ION 7650	■	■	■		■	■		■
Meter	IQ 130	■	■	■		■	■		■
Meter	IQ 140	■	■	■		■	■		■
Meter	IQ 150	■	■	■		■	■		■
Meter	IQ 230M / IQ 330M	■	■	■		■	■		■
Meter	IQ 250	■	■	■		■	■		■
Meter	IQ 260	■	■	■		■	■		■
Meter	IQ35MA1	■	■	■		■	■		■
Meter	IQ35MA2	■	■	■		■	■		■
Meter	Nexus 1200 Series	■	■	■		■	■		■
Meter	PM3_Modbus	■	■	■		■	■		■
Meter	SQD CM3000 Series	■	■	■		■	■		■
Meter	SQD CM4000 Series	■	■	■		■	■		■
Meter	SQD PM700 Series	■	■	■		■	■		■
Meter	SQD PM800 Series	■	■	■		■	■		■
Protection	ABB TPU 2000	■	■	■		■	■		■
Protection	C440	■	■	■		■	■		■
Protection	C441	■	■	■		■	■		■
Protection	EDR-3000	■	■	■		■	■		■
Protection	EDR-5000	■	■	■		■	■		■
Protection	EGR-4000	■	■	■		■	■		■
Protection	EGR-5000	■	■	■		■	■		■
Protection	EMR-3000	■	■	■		■	■		■
Protection	EMR-4000	■	■	■		■	■		■
Protection	EMR-5000	■	■	■		■	■		■
Protection	ETR-4000	■	■	■		■	■		■
Protection	ETR-5000	■	■	■		■	■		■
Protection	GE 369 Motor Relay	■	■	■		■	■		■
Protection	GE 469 Motor Relay	■	■	■		■	■		■
Protection	InsulGard	■	■	■		■	■		■
Protection	NRX520M	■	■	■		■	■		■
Protection	NRX1150M	■	■	■		■	■		■
Protection	Qualitrol 118	■	■	■		■	■		■
Starter	S611	■	■	■		■	■		■
Starter	S811	■	■	■		■	■		■
Transfer switch	ATC-300	■	■	■		■	■		■
Transfer switch	ATC-900	■	■	■		■	■		■

Power Xpert Gateway 900

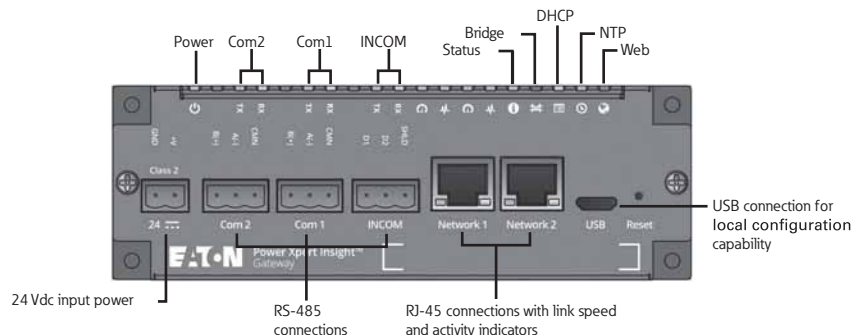

PXG Daisy Chain Application

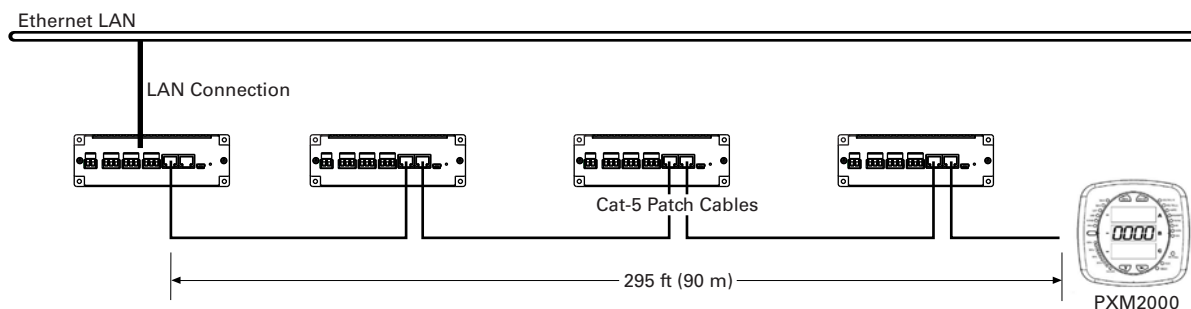

Note: In this configuration, if any of the PXG units go offline or lose power, the communication to the downstream Ethernet devices will lose connection to the LAN.



Standards and Certifications

- UL[®] 508, Standard for Programmable Controller Equipment
- FCC, Class A, Part 15, Subpart B, Sections 15.107b and 15.109b
- EN55022: 1994 Class A, Information Technology Equipment
- EN 61000-6-2:2001 Electromagnetic Compatibility (EMC) Party 6-2: Immunity for Industrial Environments



Product Selection

PXG Part Numbers

	Description	Style Number	Catalog Number
 <p>PXG900</p>	Power Xpert Gateway 900	66D2325G01	PXG900
 <p>PXG900-2A</p>	Enclosed version Cost-effective solution to add communications to new or existing equipment that has no physical space to install the PXG in the equipment structure. NEMA 12 enclosure rating. Prewired with a PSG60N24RP power supply and terminal blocks for ease of wiring of incoming power and connected devices.	—	PXG900-2A
	Power supply—24 Vdc	PSG60N24RP-A1	PSG60N24RP

Technical Data and Specifications

PXG part numbers

Description	Style Number	Catalog Number
Power Xpert Gateway 900	66D2325G01	PXG900
Power supply—24 Vdc	PSG60N24RP-A1	PSG60N24RP

Memory

- Flash: 2 GB
- RAM: 1 GB

Communication Ports

- Network ports: Two 10/100Base-T RJ-45 connectors
- Serial ports
 - Two RS-485 ports for connection to Modbus RTU devices
 - One dedicated RS-485 port for INCOM devices
- Configuration port: One USB port

Network Protocols Supported

- Modbus TCP/IP: Supports data access from Modbus TCP clients
- Web server: Supports data access from Web browsers (HTTP and HTTPS)
- DHCP: Supports automatic IP address assignments, if enabled
- NTP: Supports time synchronization via a network time server for PXG synchronization
- SMTP: Supports mail server for email notification
- BACnet/IP: Supports data access from BACnet clients

Serial Protocols Supported

- INCOM
- Modbus RTU

Web Browsers Recommended

- Internet Explorer versions 10 and 11
- Google Chrome

Power Input

- Input voltage, nominal: 24 Vdc; 0.3 A minimum
- Input voltage range: ±10% nominal

Power Consumption

- 8 W maximum

Operating Temperature

- 32 to 140 °F (0 to 60 °C)

Ambient Storage Temperature

- -40 to +185 °F (-40 to +85 °C)

Relative Humidity

- 5 to 95% noncondensing at 122 °F (50 °C)

Size (H x D x L) in Inches

- 2.00 x 4.50 x 6.00

Weight

- 1.7 pounds

Supported Devices and Performance

PXG performance will vary depending upon the number and type of connected devices. This is driven by the following:

- Each supported device has a distinct number of channels to report back to the PXG, ranging from as few as 4 to over 900
- The channels are prioritized
- Device protocol, Modbus or INCOM
- Baud rate setting

For this reason, a PXG performance tool has been developed to assist in understanding the expected performance for a given application since all systems are unique. This tool can be found at www.eaton.com/pxg. For a high level performance comparison, see the table below for three examples.

How Long Does It Take	For This Combination of Devices (All Times in Seconds)		
	64 INCOM / 32 Modbus	15 INCOM / 15 Modbus	5 INCOM
Between value change in the UI (INCOM 9600)—Priority 1	21.9	3.7	1.4
Between value change in the UI (Modbus 57600)—Priority 1	3.5	1.6	—
Between value change in the UI (INCOM 9600)—Priority 2	44.3	7.4	2.6
Between value change in the UI (Modbus 57600)—Priority 2	7.0	3.1	—
Modbus server pass-through response time (57600) (local connection)	0.061	0.059	—
For the UI to show an alarm (INCOM device)	17.0	3.0	3.0
To boot up (all devices communicating)	399.0	85.0	51.0

Note: Features and specifications listed in this document are subject to change without notice and represent the maximum capabilities of the product with all options installed. Although every attempt has been made to ensure the accuracy of information contained within, Eaton makes no representation about the completeness, correctness, or accuracy and assumes no responsibility for any errors or omissions. Features and functionality may vary depending on selected options.

General Wiring Guidelines—RS-485 Network

When communicating over RS-485 networks to Eaton products, the following General Wiring Guidelines should be used.

Rule 1: Cable Selection—Twisted Shielded Pair (TSP)

Note: Cables specifically designed for RS-485 applications are highly recommended.

The RS-485 bus is a length of Twisted Shielded Pair (TSP) that includes a third conductor (used for the common wire), a braided shield accompanied by a drain wire, and nominal impedance of 120 ohms.

- Belden Wire and Cable Company Part Number 3106A or equivalent

Rule 2: Cable Intermixing

Any cable in the Belden 3106A family can be intermixed with each other in the Modbus network.

Rule 3: System Topology, Size and Capacity

- Strict daisy chain must be adhered to. A strict daisy chain configuration is one where the transmission line connects from one RS-485 receiver to the next. The transmission line appears as one continuous line to the RS-485 driver
- Maximum 32 devices
- Line termination: Maximum cable lengths of 4000 feet (1219m); longer bus lengths will slow the data rate

Rule 4: Cable Splicing

The prime goal is to create a secure electrical connection while minimizing exposure to electrical transients. Ferrules are used to dress cable ends. Most devices have built-in terminal blocks that can be used for splicing. Additionally, terminal blocks should be utilized when splicing elsewhere in the gear or facility to ensure a secure electrical connection.

Rule 5: Cable Shielding

The cable shielding and outer jacket should not be stripped back beyond 1-1/2 inches. Three-pole terminal blocks are used to ensure a continuous metallic shield ground path. To ensure a secure electrical connection when daisy chaining devices that have built-in two-pole terminal blocks, mechanically crimp sleeves onto the two shield path drain wires.

Rule 6: Cable Grounding

Ground the communication network at only one point in the network, preferably by terminating the drain wire to ground at the EOL node (same location as the EOLR). A solid earth ground is accomplished by connecting the shield ground path's drain wire to a #14 AWG or larger multi-stranded wire that has an impedance path of 1 ohm or less to a known earth ground.

Note: The building electrical ground may not be effective since it may travel through many connections and considerable distances before reaching earth ground. In such cases, a new

ground path will be required since the effectiveness of this shield earth ground connection will affect the integrity of data transferred over the cable.

Rule 7: Cable Termination

End of Line Resistors (EOLR) are necessary to maintain signal strength and minimize reflections. EOLR must match the impedance of the TSP. Two EOLR are needed and should be located at both ends of the RS-485 bus. If there is only one device connected to the Modbus master, it is considered the last device in the network and should be terminated with a 120 ohm 1/4 watt terminating resistor.

Rule 8: Device Addressing

- Each device must have a unique slave address
- No two devices on the same RS-485 network can have the same slave address

Ethernet Cable Specifications

For complete specifications, refer to the IEEE 802.3 Ethernet specification.

RS-485 Wiring Guide—Three Terminal Devices

Device Name	A (- Wire)	B (+ Wire)	Common Wire	XCVR Common ①	Data Bias
IQ 230M	12 (MOD2)	11 (MOD1)	10 (INCOM 3)	I 26V	None
IQ 250	(-) Older Models are Marked B (-)	(+) Older Models are Marked A (-) or A (+)	SH	I	None
IQ 260	(-) Older Models are Marked B (-)	(+) Older Models are Marked A (-) or A (+)	SH	I	None
IQ 330M	12 (MOD2)	11 (MOD1)	10 (INCOM 3)	I 26V	None
NETLINK	1 (DATA-)	2 (DATA+)	5 (GND)	E	None
InsulGard ②	B	A	None	Floating	None
Bushing Gard ② (InsulGard G3 ②)	B	A	None	Floating	None
Power Xpert Meter 4000/6000/8000	Data A 750B-S	Data B 750B-S	Shield (COM)	I 300V	750 Ohm Switch Sel
Power Xpert Gateway 400/600	A(-)	B(+)	COM	I	—

Notes

① Transceiver (XCVR) Common Connected to:
 I = Isolated
 NI = Non Isolated
 E = Earth Ground

② Center terminal on InsulGard (marked with Ground symbol) is for shield splicing only and is electrically floating.

INCOM Network

INCOM was specifically designed with the intention of delivering a comprehensive and powerful energy management solution for use in electrical distribution environments while ensuring affordability, flexibility, simplicity and noise immunity. An INCOM network installed per the following rules will allow the user to fully realize all of the above advantages. (Refer to Eaton document TD17513 for specific system layout recommendations and details.)

Rule 1: Cable Selection—Twisted Shielded Pair

Approved cable types:

- Any of the cables in the Belden 9463 family
- Quabbin 6205
- CommScope 9022
- Manhattan Electric M4154
- IMPCABLE—a 600V rated cable custom designed for INCOM—
Style # 2A95705G01

Rule 2: Cable Intermixing

Due to impedance differences between IMPCABLE and the Belden 9463 family, the main cable run(s) should be entirely for the 9463 family OR IMPCABLE: do not alternate between these types. The cable used for taps can be different from the main run.

Rule 3: System Topology, Size and Capacity

Supports daisy chain, star and multi-level network segment topologies.

Note: Star Segment Topology is not recommended for new designs.

See **Page V3-T9-269**. Surge protection is required for FSK networks that leave a building at the egress/ingress of the building.

- Supports distances up to 10,000 ft (3048m) per segment when designed within the specifications of this guideline

- Supports up to 1000 devices on a single network segment
- Supports sub-network master devices and associated sub-networks
- Supports 1200 or 9600 baud rate
- Attenuation:
 - Total system capacity: 25 dB
 - Attenuation per device: 0.01 dB
 - Attenuation for approved wire types, see tables below

Cable Attenuation

Cable Type	Attenuation/ 1000 Feet (305m)
IMPCABLE	1.6 dB
Belden 9463 family	2.0 dB

Attenuation at Star

Number of Long Lines	Attenuation
3	3.5 dB
4	6 dB
5	8 dB

- Definitions:
 - **Daisy chain:** point-to-point wiring between devices or clusters of devices
 - **Star:** single point with a number of long lines emanating from it
 - **Long line:** >200-foot (61m) wire run
 - **Simple tap:** <200-foot (61m) connection to cluster of devices

Rule 4: Cable Splicing

The goal is to create a secure electrical connection while minimizing exposure to electrical transients. Ferrules are used to dress cable ends in order to avoid problems associated with frayed and loose wires. Besides facilitating cable installation, subsequent data line troubleshooting and downtime are minimized. Most INCOM devices have built-in three-pole terminal blocks for data lines and shield. For older INCOM devices that have only two terminals, shield continuity

must be ensured by other means. Additional terminal strips should be utilized when splicing elsewhere in the electrical enclosure or facility to ensure secure electrical connections. All devices, End of Line Termination Resistors and Taps should be wired in parallel across the cable.

Rule 5: Cable Shielding

The cable shielding and outer jacket should not be stripped back beyond 1.5 inches (38 mm). Terminal blocks are used at tap points to ensure a continuous metallic shield ground path. To ensure a secure electrical connection when daisy-chaining INCOM devices that have built-in two-pole terminal blocks, use crimp sleeves to join the two shield drain wires. The cable shield ground path for a main network and sub-network must not be joined. Each should have a separate connection to earth ground reference.

Rule 6: Cable Grounding

The shield should be continuous across a network segment and connected to the building's electrical system grounding electrode conductor. The 2005 NEC provides the following guidance on grounding communication cables:

1. When a communication cable enters a building, a primary protector is required and must be grounded as described in Section 800 IV. Specifically, Paragraphs 800.93 and 800.100 define grounding requirements for the primary protector.
2. Grounding systems are generally covered by Section 250 III. The grounding electrode conductor is specifically covered by Paragraphs 250.62, 250.64, 250.66, 250.68 and 250.70.
3. Bonding requirements between communication systems and the power distribution system is specified by Paragraph 250.94.

A solid earth ground is accomplished by connecting the shield ground path's drain wire to a #14 AWG or larger multi-stranded wire that has an impedance path of 1 ohm or less to the building's grounding electrode conductor.

Rule 7: Cable Termination

Each network segment requires a minimum of two End of Line Termination Resistors (EOLTRs). The EOLTRs maintain signal strength and minimize reflections. The EOLTRs should be 1/2 watt 100 ohm non-inductive resistors, such as carbon composition or metal film. Wire-wound resistors are not acceptable. Taps on network segments should not be terminated. Some INCOM devices have the EOLTR permanently installed and must be located at the end of a main run. Other INCOM devices have an EOLTR that can be switched to optionally terminate the network segment at the device. Care must be exercised when installing devices containing termination resistors that the switches are set appropriately. A minimum of two, up to a maximum of five EOLTRs must be installed on each network segment as dictated by network topology.

Rule 8: Device Address

In order to avoid the possibility of devices in a Main Network having the same addresses as those in Subnetworks, set Main Network device addresses at 100 or higher excluding addresses 901 to 908.

Dimensions

Approximate Dimensions in Inches (mm)

Power Xpert Gateway 900 with Standard Panel Mounting (Brackets Included)

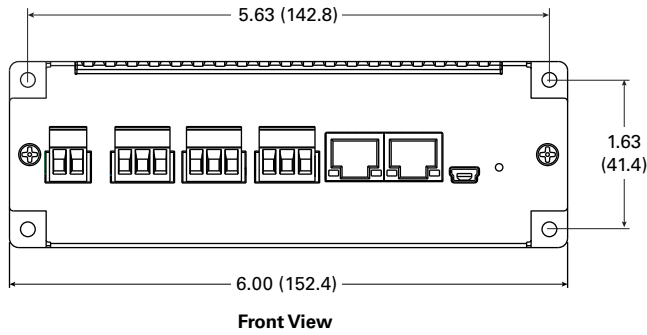

Power Xpert Gateway 900 with DIN Rail Mounting

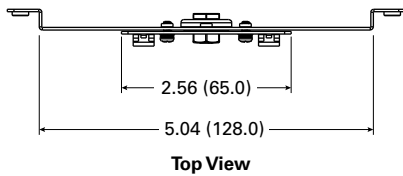

Remove and then reattach these screws to rotate for vertical mounting

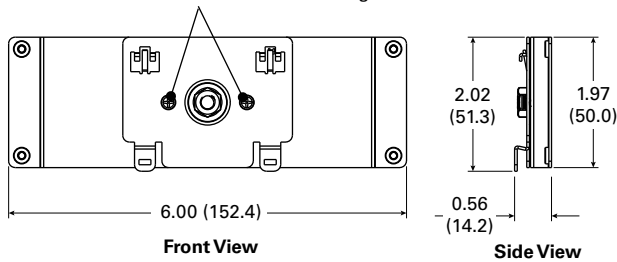

Power Xpert Gateway 900

Width	Height	Depth	Shipping Weight Lbs (kg)
6.00 (152.4)	2.00 (50.8)	4.50 (114.3)	1.70 (0.8)

Power Xpert Ethernet Switches



Convenient Network Expansion

Contents

<i>Description</i>	<i>Page</i>
Power Xpert Gateway	V3-T9-261
Power Xpert Ethernet Switches	
Product Selection	V3-T9-271
Accessories	V3-T9-271
Technical Data and Specifications	V3-T9-271
Dimensions	V3-T9-273
mMINT	V3-T9-274
IPONI	V3-T9-276
DPONI	V3-T9-277
MPONI	V3-T9-278
I/O Devices Digital Input Module (DIM)	V3-T9-279
Addressable Relay II	V3-T9-281
Breaker Interface Module II (BIM II)	V3-T9-283

Power Xpert Ethernet Switches

Product Description

Eaton's Power Xpert Ethernet Switches are ideal for extending Ethernet networks via CAT5 wiring or fiber in harsh, industrial environments. Built with high-grade components and constructed using special thermal techniques, PXE Switches can withstand the unpredictable conditions of such environments.

Features

- Simultaneous, full-duplex, high-speed communication on all ports—no network performance bottlenecks
- Hardened for factory floor—ideal for both industrial or data center applications
- Unmanaged, plug-and-play implementation—no software or additional hardware required for configuration
- Seamlessly integrates into Eaton's Power Xpert Architecture—quality and reliability of Eaton guaranteed
- Mounting options include standalone panel-mounting, DIN rail mounting, or 19-inch standard rack mounting

PXES 6-Port Switch—10/100 Mb with Optional 100 Mb Fiber

This compact switch provides six Ethernet ports, with flexible configurations. The base models have one of three options:

- Two 100 Mb fiber and four 10/100 copper ports
- One fiber and five copper ports
- Six copper ports

PXES 4-Port Switch—10/100 Mb

For smaller applications requiring fewer connection points and no fiber, the 4-port Power Xpert Ethernet Switch is a versatile option. It provides edge access Ethernet ports in a convenient and compact package.

Standards and Certifications

- UL Listed (UL 60950)
- cUL
- CE
- Emissions meet FCC Part 15, Class A



Product Selection

Ethernet Switch



Power Xpert Ethernet Switches

Description	Catalog Number
4-port Ethernet switch—copper only	PXES4P24V
6-port Ethernet switch—copper only	PXES6P24V
6-port Ethernet switch—5 copper/1 fiber (ST connector)	PXES6P24V1ST
6-port Ethernet switch—4 copper/2 fiber (ST connector)	PXES6P24V2ST

Accessories

Ethernet Switch



Power Xpert Ethernet Switches

Description	Catalog Number
Power supply (preferred)—100–240 Vac input DIN rail mount with screw—24 Vdc output terminals	ELC-PS02
Power supply (alternate)—120 Vac input Wall plug-in type with 6 ft cord—12 Vdc output	PXESPS12V
DIN rail mounting bracket	PXESDINRL
19-inch rack mount tray	PXESTRAY

Technical Data and Specifications

Operating Environment

Description	Specifications
Ambient temperature ratings	–25°C to 60°C long-term per independent agency tests (UL), or –40°C to 85°C short-term per IEC type tests
Storage temperature	–40° to 185°F (–40°C to 85°C)
Cold start	to –20°C
Ambient relative humidity	5%–95% (noncondensing)
Altitude	–200 to 50,000 ft (–60 to 15,000m)
MTBF	> 15 years

Network Standards

Description
Ethernet IEEE 802.3, IEEE 802.3u; IEEE 802.1p, 100Base-TX, 10Base-T, 100Base-FX

Power Consumption

Description
7.0 watts typical—9 watts maximum

Packaging

Description	Specifications
Enclosure	Robust sheet metal (steel)
Cooling method	Case used as a heat sink

Mounting

Description	Specifications
Metal panel mounting clips	Included
DIN rail mounting	Optional
19-inch rack mount	Optional

Copper Ethernet Cable Wiring Guidelines

The following information can be used as a guide when designing an Ethernet system using Copper Ethernet Cable.

- Cables should not be routed near equipment that generates strong electric or magnetic fields such as motors, drive controllers, arc welders and conduit
- Ethernet cable insulation has a voltage rating of 300 Vac. Use of barriers, cable trays or high voltage sheathing with STP Ethernet cable may be required in installations with cables carrying voltages greater than 300 Vac. This may also be necessary in order to comply with UL requirements. In installations where the cable cannot be physically separated from the power cables (where a physical barrier is not practical) fiber optic cable should be used
- When crossing power conductors with Ethernet cable, cross at right angles
- Shielded Twisted Pair (STP) Ethernet cable should be specified for use in high noise environments. Shielded shrouded connectors must be used and the shield must be connected at both ends of the wire. The mating plug must have a shielded shroud that is terminated to ground at both ends. Where there is a possibility of a difference in ground potential (common mode) voltages between the two terminated ends, fiber optic cable is recommended
- When using conduit or a metal cable tray, each section of the conduit or tray must be bonded to each adjacent section and the conduit or tray needs to be bonded to earth ground. Do not allow the shields to touch the conduit or metal tray at any point
- Only shielded (STP) Ethernet cables should be placed into metal conduit. Some UTP cables may not function properly when installed in conduit, as the metal conduit can affect the electrical properties of an unshielded cable. Consult the cable manufacturer when installing UTP cables in conduit
- As a general rule for noise protection, Ethernet Cable should maintain a minimum distance of 3 inches (8 cm) from electric power conductors for up to 100 volts and 1 inch (3 cm) for each additional 100 volts up to 400 volts. STP cable is recommended
- For Ethernet cable run within conduit, but near conductors with potentially noisy power conductors carrying currents of greater than 20A or voltages greater than 400V, maintain the following distances. STP cable is required.
 - Conductors of less than 20A = 3 inches
 - Conductors of 20A or more and up to 100 kVA = 6 inches
 - Conductors greater than 100 kVA = 12 inches
- For Ethernet cable run near conductors with potentially noisy power conductors carrying currents of greater than 20A or voltages greater than 400V, maintain the following distances. STP cable is recommended
 - Conductors of less than 20A = 6 inches
 - Conductors of 20A or more and up to 100 kVA = 12 inches
 - Conductors greater than 100 kVA = 24 inches
- Route Ethernet cable at least 5 feet (1.5m) from sources of rf/microwave radiation. STP cable is required
- Do not cascade more than four Ethernet repeaters (router, switch or hub) within a network segment
- Environmentally sealed connectors should be specified for cables used in outdoor installations
- Avoid pinching the cable when using cable ties
- Total distance between an Ethernet Transmitter and Receiver at the end points of the network should not exceed 328 feet (100m)
- Total distance from a patch panel to a wall jack (using solid cable) shall not exceed 295 feet (90m). Splices are not permitted
- Patch cords used as cross-connect jumpers in a patch panel should not exceed 20 feet (6m)
- Patch cords from a wall jack to the work area PC (or device) shall not exceed 16 feet (5m)
- Ethernet cable used in harsh environments must be selected to withstand the following conditions: vibration, air born contaminants, chemicals, temperature, electromagnetic interference, combustible atmospheres and local regulatory standards such as UL and NEMA
- Ethernet connectors used in harsh environments must be robust enough to withstand vibration, multiple connection cycles, temperature changes, and provide a proper seal to protect against moisture, dust/dirt and chemical attack
- Different cable media support different bandwidth capabilities. When installing cable in a network, care should be taken to install the cable that will fill current network loading requirements and future expansion needs. In general, fiber optic cable can support the greatest bandwidth (upward of 25,000 gigabits) and UTP has the lowest. CAT5e cabling is designed to operate a bit rates up to 1000 Mb and CAT6 cable up to 2000 Mb
- Operating your cable at maximum speed reduces the distance between network segments. Check with your cable supplier for specifications regarding segment distance vs. speed
- Cable with 5% impedance mismatch or return loss of 27 to 32 dB is recommended. Ethernet cable impedance can vary by as much as 15% (85 to 115 ohms). Average Ethernet cable with 15% impedance variation can have up to 10 dB additional return loss. This discontinuity is referred to as return loss, since it causes some of the signal to be reflected back down the cable instead of propagating forward. It is measured in decibels or ratio of transmitted versus reflected signal

Fiber Optic Technology

The use of fiber optics in telecommunications and wide area networking has been common for many years, but more recently fiber optics have become increasingly prevalent in industrial data communications systems as well. High data rate capabilities, noise rejection and electrical isolation are just a few of the important characteristics that make fiber optic technology ideal for use in industrial and commercial systems.

Although often used for point-to-point connections, fiber optic links are being used to extend the distance limitations of RS-232, RS-422/485 and Ethernet systems while ensuring high data rates and minimizing electrical interference.

Conventional electrical data signals are converted into a modulated light beam, introduced into the fiber and transported via a very small diameter glass or plastic fiber to a receiver that converts the light back into electrical signals.

Optical fibers allow data signals to propagate through them by ensuring that the light signal enters the fiber at an angle greater than the critical angle of the interface between two types of glass. Optical fiber is actually made

up of three parts. The center core is composed of very pure glass. Core dimensions are usually in the range of 50 to 125 um for multi-mode cables and 8-9 um for single-mode cables. The surrounding glass, called cladding, is a slightly less pure glass. The diameter of the core and cladding together is in the range of 125 to 440 um.

Surrounding the cladding is a protective layer of flexible silicone called the sheath.

Fiber Optic Cable Wiring Guidelines

The following information can be used as a guide when designing an Ethernet system using Fiber Optic Ethernet Cable:

- Select a fiber cable that is suited for the application, e.g., outdoor, aerial, duct, intra-building, risers, general building and plenum applications
- Fiber optic cable is useful in applications where the environment is combustible, electrically noisy, the cable must be bundles with high voltage wires or where common mode voltages may exist between the earth ground points of the terminating connectors

- Fiber optic cable is available in various operating temperature ranges. Care should be taken to match the temperature rating of the fiber to the environment it will be exposed to. The temperature specification for fiber may be narrower than copper cable. Consult the cable manufacturer for temperature specifications of your cable type
- Sealed fiber connectors are available for use in harsh environments to prevent contamination from entering the connector and fiber. The type of seal required will be application dependant and can vary from dust- and moisture-proof to water-tight
- Mixing fiber cable types is not permitted. The same core dimensions and mode must be used within cable segments
- Care should be taken when purchasing connectors to include strain relief, which reduces mechanical strain (vibration) within the cable, as well as the connector. Strain relief also provides support to the cable to ensure proper bend radius at the connector
- Single-Mode Fiber is used for long distance transmission of up to 120 km. Distance may vary depending on speed and type of converter used
- Multi-Mode Graded-Index Fiber Cable is used for communication over shorter distances of up to 2 km
- Fiber cable is composed of glass and is not well suited for applications requiring tight bend radiuses. Cable radius dimensions vary per manufacturer. If the manufacturer does not provide a bend radius, a typical rule of thumb is a radius not less than 15x the cable diameter
- Fiber cable to connector terminations can be performed in the field using special equipment. This method is not recommended
 - Tier One testing is recommended when diagnosing system irregularities and should be performed in all new installations
 - Tier Two testing is recommended to certify that a system complies with standards set forth by the owner/installer

Dimensions

Packaging

Description	Specifications
Dimensions of PXES4P series Weight of PXES4P series	3.5 in H x 3.0 in W x 1.0 in D (8.9 cm x 7.6 cm x 2.5 cm) 8.6 oz. (243g)
Dimensions of PXES6P series Weight of PXES6P series	3.6 in H x 3.0 in W x 1.7 in D (9.2 cm x 7.6 cm x 4.3 cm) 13 oz. (370g)

mMINT Module



mMINT

Product Description

The mMINT (Modbus Master INCOM Network Translator) Module is an Eaton accessory product that provides communication between a Modbus RTU network and an INCOM (Industrial COMmunications) network (see **Page V3-T9-275**). This module is transparent to the Modbus network. It communicates to a master on the Modbus network using the Modbus RTU (Remote Terminal Unit) protocol. It communicates to slave devices on the INCOM network using the IMPACC (Integrated Monitoring, Protection, And Control Communication) protocol.

Features

The mMINT module is a slave device on the Modbus network and as such requires a master that will exchange register objects with the mMINT module.

- Handles generic pass-through commands (Modbus/INCOM/Modbus)
- Capable of passing Modbus register objects from Eaton's existing products and newer PnP (Plug-n-Play) products to a Modbus RTU master
- Data in IEEE Floating Point format and fixed point
- Modbus RTU communications data transfer rates of 1200, 9600 or 19,200 baud with one start bit, eight data bits, no parity, and either one or two stop bits

Contents

<i>Description</i>	<i>Page</i>
Power Xpert Gateway	V3-T9-261
Power Xpert Ethernet Switches	V3-T9-270
mMINT	
Technical Data and Specifications	V3-T9-275
IPONI	V3-T9-276
DPONI	V3-T9-277
MPONI	V3-T9-278
I/O Devices Digital Input Module (DIM)	V3-T9-279
Addressable Relay II	V3-T9-281
Breaker Interface Module II (BIM II)	V3-T9-283

Standards and Certifications

- UL
- CSA
- CE mark



Product Selection

The catalog number of this product is mMINT.

Technical Data and Specifications

Module Mounting

When mounting the mMINT, verify that an 11 mm H x 28 mm W DIN rail is used and that it is within an enclosed space.

Simplified Wiring Rules

INCOM Network

The following simplified rules apply to a given system consisting of a single daisy-chained main cable link between master and slave devices (see below). For more complex considerations including star configurations, please refer to the IMPACC wiring specification T.D. 17513.

- Recommended INCOM cable styles are Belden 9463 or C-H style 2A957805G01
- The maximum system capacity is 10,000 feet of communications cable and 32 slave devices on the INCOM network under the mMINT
- Non-terminated taps, up to 200 feet in length, off the main link are permitted, but add to the total cable length
- Make sure that there is twisted-pair wire that is recommended for IMPACC network use. Use shielded twisted-pair wire to connect each slave to the INCOM network, daisy-chain style. The polarity of the twisted pair is not important

Modbus RS-485 Network

The following simplified rules apply to a given system consisting of a cable link between master and slave devices (see below). For more complex configurations, please refer to standard Modbus RTU wiring specification rules for the RS-485 network.

- The recommended Modbus cable has twisted-pair wires (24 AWG stranded 7x32 conductors with PVC insulation) having an aluminum/mylar foil shield with drain wire
- The maximum system capacity is 4000 feet of communications cable and 247 devices on the Modbus RTU network
- Make sure that there is twisted-pair wire that is recommended for Modbus RTU network use. Use shielded twisted-pair wire to connect each slave to the Modbus RTU network, daisy-chain style. The polarity of the twisted pair is critically important

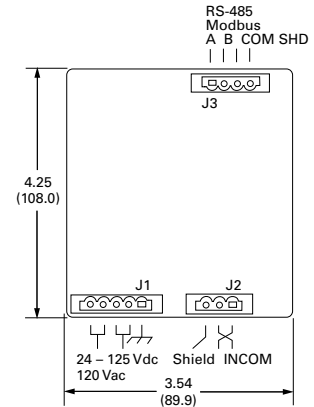

mMINT Module Dimensions

Burden

- 24 Vac/dc 3 VA

Communications Speed

- INCOM: 1200, 9600 baud
- N2 Bus: 9600 baud

Note: Contact Eaton for availability and support for the N2 Gateway.

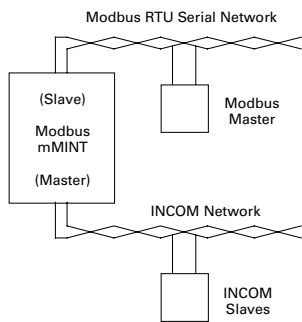

mMINT in a Communications Network

IPONI Communication Module



Contents

<i>Description</i>	<i>Page</i>
Power Xpert Gateway	V3-T9-261
Power Xpert Ethernet Switches	V3-T9-270
mMINT	V3-T9-274
IPONI	
DPONI	V3-T9-277
MPONI	V3-T9-278
I/O Devices Digital Input Module (DIM)	V3-T9-279
Addressable Relay II	V3-T9-281
Breaker Interface Module II (BIM II)	V3-T9-283

IPONI

Product Selection Guide

IPONI Selection Chart

Description	IPONI	INCOM on Product	MPONI
IQ Analyzer	■	—	■
IQ DP-4000	■	—	■
IQ 200	—	■	—
IQ Multipoint Energy Submeter II	—	■	—
Energy Sentinel	—	■	—
Power Sentinel	—	■	—
IQ Generator	■	—	—
IQ Data	■	—	—
IQ Data Plus II	—	—	—
IQ 500	—	—	—
IQ Transfer	■	—	—
AEMII	■	—	—
BIM II	■	—	—
CMU	■	—	—
CED	■	—	—
MP-3000	■	—	■
Digitrip 3000	—	■	—
FP-5000	—	■	—

Product Description

The INCOM Product Operated Network Interface card, or IPONI card, adds communication capability to various Eaton products. Each IPONI has three 16-digit address switches to uniquely identify each device on the network. IPONIs are designed to be daisy-chained throughout a unit substation or equipment room to a master device such as a mMINT, MINTII or Power Xpert Gateway. From the master computer, information is distributed through the facility's TCP/IP Ethernet network. A twisted shielded pair network connecting IPONIs may extend up to 10,000 feet (3048m) before terminating a master device. The IPONI comes with mounting hardware and attaches to the back of its associated device.

Technical Data and Specifications

- Temperature**
 - -20°C to 70°C
- Humidity**
 - 5%–95% noncondensing
- Power**
 - 20–30 Vdc maximum, 50 mA nominal, 100 mA maximum
- Speed**
 - 1200 and 9600 baud
- Communications**
 - Three-position removable terminal block for twisted shielded pair INCOM

Product Selection

IPONI Card



PONI Communication Modules

Description	Catalog Number
INCOM PONI	IPONI

Contents

<i>Description</i>	<i>Page</i>
Power Xpert Gateway	V3-T9-261
Power Xpert Ethernet Switches	V3-T9-270
mMIINT	V3-T9-274
IPONI	V3-T9-276
DPONI	
MPONI	V3-T9-278
I/O Devices Digital Input Module (DIM)	V3-T9-279
Addressable Relay II	V3-T9-281
Breaker Interface Module II (BIM II)	V3-T9-283

DPONI

Product Description

The DeviceNet Product Operated Network Interface (DPONI) enables communication between a DeviceNet network master station and a host device in a Master/Slave format over a DeviceNet network. The DPONI is compatible with the MP-3000 and the MP-4000. The DPONI is powered both by the host product to which it is attached and by the DeviceNet network. The DPONI uses opto-couplers to isolate the two power systems.

The DPONI communicates at 125, 250 or 500 Kbps selected via a front panel DIP switch. All products on the DeviceNet network must be set at the same communication rate.

The DPONI has a bi-color network/module status LED that functions in accordance with the DeviceNet specification. An additional monocolor LED flashes while the DPONI is receiving a message from the host device.

Features

Eaton's DPONI

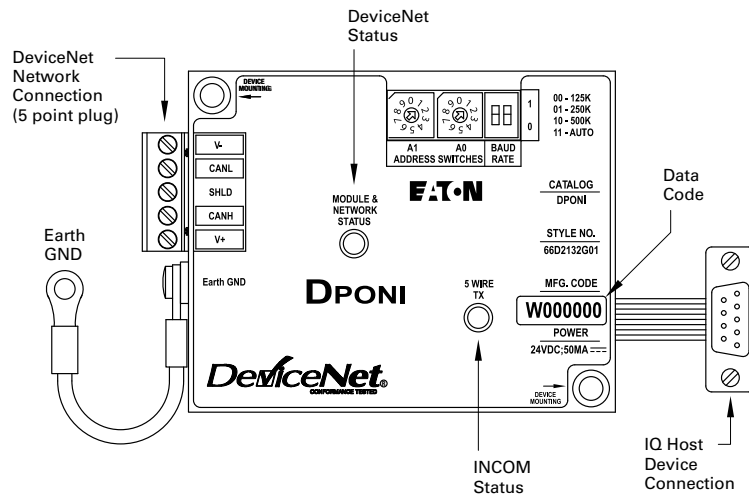

Product Selection

DPONI

Description	Catalog Number
The DeviceNet Product Operated Network Interface	DPONI

Technical Data and Specifications

Temperature

- -20°C to 70°C

Humidity

- 5%–90% noncondensing

Power

- 11–27 Vdc, 40 mA maximum

Speed

- 125, 250 or 500 Kbps

Communications

- Standard five-wire CAN connection

Contents

<i>Description</i>	<i>Page</i>
Power Xpert Gateway	V3-T9-261
Power Xpert Ethernet Switches	V3-T9-270
mMINT	V3-T9-274
IPONI	V3-T9-276
DPONI	V3-T9-277
MPONI	
I/O Devices Digital Input Module (DIM)	V3-T9-279
Addressable Relay II	V3-T9-281
Breaker Interface Module II (BIM II)	V3-T9-283

MPONI

Product Description

The MPONI Product Operated Network Interface card, or MPONI card, enables Modbus communication capability to various Eaton products. Each MPONI contains two rotary address switches to uniquely identify each device on the network and a baud rate DIP switch. A 5-pin connector is provided for wiring to the RS-485 network. Various baud rates are available for networking flexibility, and onboard LEDs indicate operation, error and communication status. The MPONI is applied where a device network exists connected by a dedicated shielded twisted pair conductor. Modbus RS-485 allows a single device or multiple units in a daisy-chain configuration to communicate with another local or remote device and may extend up to 4000 feet (1219m) without a repeater. The MPONI comes with mounting hardware and attaches to the back of its associated device.

Note: Please see IL for detailed register support information for each supported product. Not all device functionality is supported with the RS-485 PONI over the Modbus Protocol.

Features

MPONI

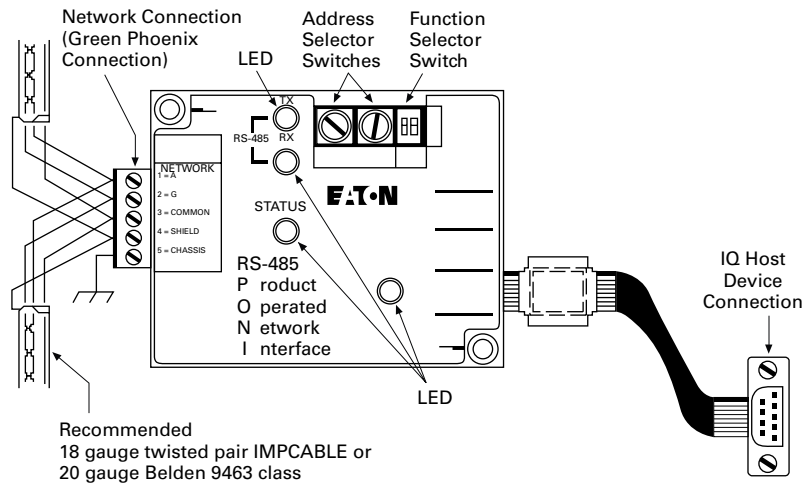

Product Selection

MPONI

Description	Catalog Number
Modbus Product Operated Network Interface Card	MPONI

Digital Input Module (DIM)



Contents

<i>Description</i>	<i>Page</i>
Power Xpert Gateway	V3-T9-261
Power Xpert Ethernet Switches	V3-T9-270
mMINT	V3-T9-274
IPONI	V3-T9-276
DPONI	V3-T9-277
MPONI	V3-T9-278
I/O Devices Digital Input Module (DIM)	
Product Selection	V3-T9-280
Technical Data and Specifications	V3-T9-280
Dimensions	V3-T9-280
Addressable Relay II	V3-T9-281
Breaker Interface Module II (BIM II)	V3-T9-283

I/O Devices Digital Input Module (DIM)

Product Description

Eaton’s Digital Input Module is a device that interfaces with up to four standard utility (electric, gas, water) meters or monitors eight digital inputs. It translates KYZ pulses from meters into a register count that is maintained and compiled within the DIM module in non-volatile memory. The pulse count can be accessed from the DIM module remotely using Eaton Power Management Software, including the Energy Billing application.

The DIM can also be used to monitor eight digital inputs from switch closures.

Features, Benefits and Functions

- Reads four separate KYZ equipped utility meters
- Pulse counts stored in non-volatile memory
- Each channel independently monitors KYZ counts, pulse counts, or digital indications
- Monitors a maximum of eight individual digital inputs
- Input channels are isolated
- Isolated 24 Vdc power is provided on the I/O connector
- LED indicators on the input channels indicate when the unit is counting
- 10 LED status indicators, 100 ohm termination DIP switch, address selector switches
- DIN rail mounting

Standards and Certifications

- UL 873
- CE mark (48 Vdc operation)
- FCC Part 15, Class A
- IEC 1000-4-x
- CISPR 22, Class A
- IEC 1000-4-2; 1995, Electro Static Discharge
- IEC 1000-4-3; 1995, Radiated RF Immunity
- IEC 1000-4-6; 1996, Conducted RF Immunity
- FCC Part 15 Class A (10 meters) Radiated Emissions
- CISPR 22, Class A (30 meters); 1991, Radiated Emissions
- CISPR 22, Class A; 1991, Conducted Emissions (PowerPort)



Product Selection

DIM



Ordering Information

Description	Catalog Number
Digital Input Module	DIM

Technical Data and Specifications

Specifications

Description	Rating
Operating temperature	-20°C to 60°C
Storage temperature	-20°C to 70°C
Operating Humidity	5 to 90% maximum noncondensing
Altitude	10,000 ft. (3048m)
Environment	Indoor use only
Transient overvoltage	Category 2
Pollution	1°
Equipment	Class 1

Frequency Range

- 50/60 Hz

Power

- 85 to 138 Vac (120 Vac nominal) 50/60 Hz; 100 mA
- 48–128 Vdc (48 Vdc nominal); 100 mA
- Brownout operation at 50% and 80% of nominal AC and DC ratings
- Power input is provided from a limited source, isolated from the mains by double isolation
- Power for all inputs is supplied from an internal, isolated 24 Vdc power source

Mounting Information

The DIM module is designed to be DIN rail mountable. DIN rail must be 1/3 inches H x 1-3/8 inches W (8.5 mm H x 34.9 mm W).

Communications

The DIM is a fully compatible Power Management Software communicating device with built-in INCOM communications. The DIM comes complete with a 3-pin connector to receive the shielded twisted pair conductor.

All wiring must be complete as per Instruction Leaflet TD17513, Wiring Specification Base Rules.

Dimensions

Approximate Dimensions in Inches (mm)

KYZ Input Module

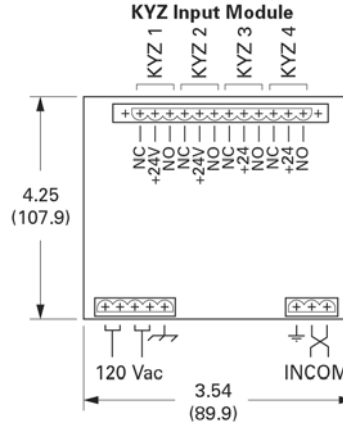

KYZ Input Module

Width	Height	Depth
3.54 (89.9)	4.25 (107.9)	3.50 (88.9) ①

Note

- ① Does include DIN rail.

Addressable Relay II



Contents

<i>Description</i>	<i>Page</i>
Power Xpert Gateway	V3-T9-261
Power Xpert Ethernet Switches	V3-T9-270
mMINT	V3-T9-274
IPONI	V3-T9-276
DPONI	V3-T9-277
MPONI	V3-T9-278
I/O Devices Digital Input Module (DIM)	V3-T9-279
Addressable Relay II	
Product Selection	V3-T9-282
Technical Data and Specifications	V3-T9-282
Dimensions	V3-T9-282
Breaker Interface Module II (BIM II)	V3-T9-283

Addressable Relay II

Product Description

The Addressable Relay II is designed for use where information or control of non-communicating devices is required remotely. The relays communicate at 9600/1200 baud on the INCOM network. Devices are assigned a three-digit address to uniquely identify them on the daisy-chained twisted shielded pair network.

The Addressable Relay II is a Form C relay on terminals 1, 2 and 3, with output contact ratings as shown in the Contact Ratings table. The Addressable Relay II may be powered by 48–120 Vac or 48–125 Vdc through terminals 11 and 12 of the terminal block. DC polarity is not significant.

Application Description

- Enables remote control of non-communication capable devices on Eaton’s PowerNet system
- Monitors two digital status inputs on the PowerNet system

Features, Benefits and Functions

Each Addressable Relay II includes two status indicating circuits (IN1 and IN2) that can be used to transmit the contact status of devices external to the Addressable Relay II. Each input is isolated with its own return. A typical installation using these report-back inputs to the Eaton PowerNet system is shown in the wiring example. Terminals 4 and 5 connect to the status input 1 circuit (IN1) and terminals 6 and 7 connect to the status input 2 circuit (IN2). These status indicating circuits operate with input voltages of 48–120 Vac or 48–125 Vdc circuits.

The Addressable Relay II includes a feature called the “communications watchdog.” The communications watchdog monitors communications between the Addressable Relay II and the computer control station. If communications are lost, the communications watchdog will reset the relay to the de-energized (OFF) state. The Addressable Relay II must be updated every 10 seconds when the communications watchdog is enabled or else communications are assumed to be lost. The communications watchdog is enabled when DIP switch 3 is set to the ON position. When the communications watchdog is not enabled, the relay will remain in the state set by the last command issued. **See V3-T9-286** for DIP switch configuration.

Monitored Parameters

- Output relay energized/de-energized
- Input 1 status
- Input 2 status
- Breaker status open/closed
- Protective relay status normal/tripped

Communications

- Built-in INCOM communications for monitoring in Eaton’s PowerNet system

The Addressable Relay II also includes a feature called “relay pulse.” The relay pulse feature sets the Addressable Relay II to a pulse mode where the relay is energized (ON) for 10 seconds and then is de-energized (OFF). The relay pulse is enabled when DIP switch 2 is set to the ON position and disabled when DIP switch 2 is set to the OFF position. If this feature is not enabled, the relay will remain in the state set by the last command.

9.4

Metering Devices, Protective Relays, Software and Connectivity

Connectivity Options

Product Selection

Addressable Relay II



Addressable Relay

Description	Catalog Number
Addressable Relay II	ARII

Technical Data and Specifications

- Power: 48–120 Vac; 48–125 Vdc
- Operating temperature range: 32°–158°F (0°–70°C)

Contact Ratings

Contact Ratings	Make	Break
120–240 Vac	4960 VA	828 VA
24–120 Vac	43A	7.2A
30 Vdc	10A	10A

Wiring Diagram

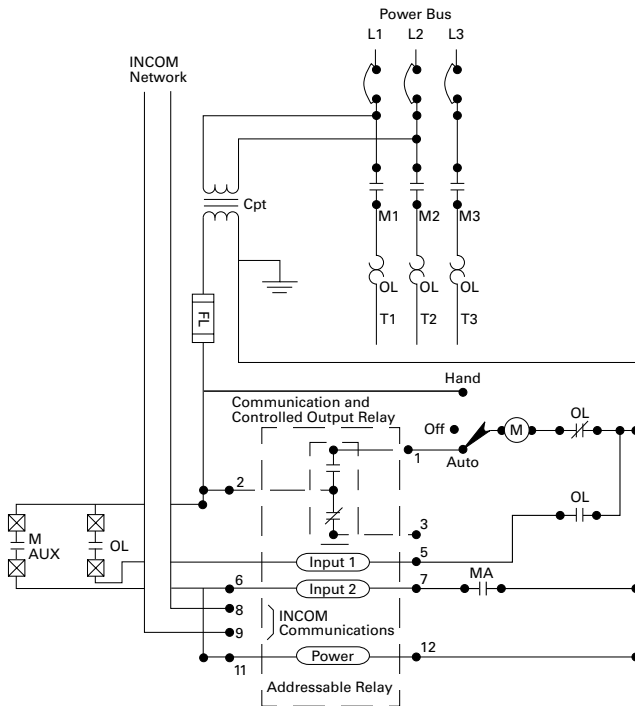

DIP Switch Functions

DIP Switch	OFF	ON
1	Baud Rate 9600	1200
2	Relay Pulse Disabled	Enabled
3	Communications Watchdog Disabled	Enabled

Dimensions

Approximate Dimensions in Inches (mm)

Mounting

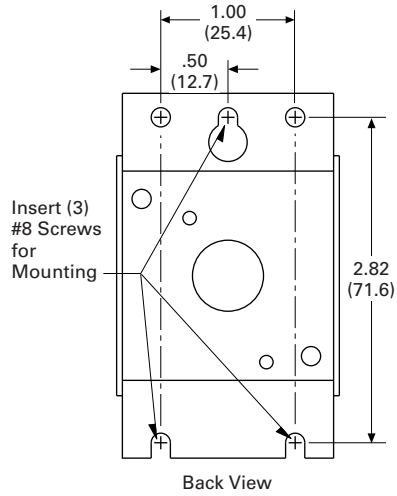

Addressable Relay

Width	Height	Depth
1.75 (44.5)	3.00 (76.2)	4.00 (101.6)

Breaker Interface Module II (BIM II)



Contents

<i>Description</i>	<i>Page</i>
Power Xpert Gateway	V3-T9-261
Power Xpert Ethernet Switches	V3-T9-270
mMINT	V3-T9-274
IPONI.	V3-T9-276
DPONI	V3-T9-277
MPONI	V3-T9-278
I/O Devices Digital Input Module (DIM)	V3-T9-279
Addressable Relay II	V3-T9-281
Breaker Interface Module II (BIM II)	
Features, Benefits and Functions	V3-T9-284
Product Selection	V3-T9-285
Technical Data and Specifications	V3-T9-285

Breaker Interface Module II (BIM II)

Product Description

Eaton’s Breaker Interface Module is a panel-mounted device that displays the following parameters.

- Phase current
- Energy
- Present demand watts
- Peak demand watts
- Average demand current
- Cause and magnitude of trip
- Trip history
- % Total Harmonic Distortion (THD) for each phase
- % Harmonic Content for each phase (1st–27th harmonic)
- Custom circuit description

Note: The Breaker Interface Module displays only a portion of the information it receives from the Digitrip RMS 910, 1150 and Power Sentinels. The balance of the information (such as Waveform Analysis and Power Factor) can be passed through the unit to a master computer, where it can be viewed.

Application Description

- 810, 910, 750, 1050, 550, 1150, 520MC, IQ Energy Sentinels and Power Sentinels
 - Event logging
 - Alarming
 - High load indication
 - Peak exceeded alarm
 - Grouping of meters
- An operator can use the Breaker Interface Module to:
- Complete Initial System Setup:
 - Select system frequency (50/60 Hz)
 - Set password
 - Configure OPTIM Protective Settings.
 - Select protection options
 - Select alarm levels
 - Display Information:
 - Metered values
 - Trip event information
 - Breaker information
 - Time-current set points

- Test OPTIM Trip Unit Performance:
 - Phase and ground
 - Trip/no trip
- Expanded Energy Monitoring:
 - Set addresses for group energy monitoring
 - Group energy readings
- Local and Remote Indication:
 - Remote indication/ alarming
 - Breaker status LED indication
- Expanded Communications:
 - Communicate with:
 - OPTIM Trip Units
 - Digitrip RMS 810, 910 and 1150 Trip Units
 - IQ Energy Sentinels and Universal IQ Energy Sentinels
 - A total of 50 devices

Features, Benefits and Functions

- Monitors and displays parameters from any combination of Digitrip RMS 810, 910, 1150 and Digitrip OPTIM Trip Units, F/J-/K-Frame Energy Sentinels, and Universal Energy Sentinels, supporting as many as 50 of these devices up to 10,000 feet (3048m) away
- Communicates the information from these protective and energy monitoring devices over Eaton INCOM network to a computer or PLC
- Continuously monitors breakers recording and time-stamping trip events along with approximate fault currents. Events are logged into non-volatile RAM

Physical Characteristics

- Graphical, glass plasma display
- Up to seven lines of information
- Membrane faceplate NEMA 3R and 12 rated

Communications

Depending upon the type of communication protocol used by the main network, an appropriate PONI module can be easily field-mounted to the back of the Breaker Interface Module, enabling the unit to pass the information from its subnetwork to a remote master control unit up to 10,000 feet (3048m) away. No reprogramming of the unit is required when the PONI is added.

The Breaker Interface Module can be mounted directly on the assembly or at a remote location and can be used to access and configure and display information from OPTIM Trip Units.

Password Protection

A user-defined password is included for added security when changing settings or performing breaker tests.

Non-Volatile Memory

The programmed functions, addresses and circuit descriptions are stored in non-volatile memory.

External Power

A 24 Vdc supply is required for the BIM II. (No external power supply is required for the PONI Card.) A 120 or 240 Vac supply is required for the BIMPS.

Rear Access Area

All wiring connections to the Breaker Interface Module are made at the chassis' rear and include:

- Relay connection for "alarm" condition, "high load" condition, "peak exceed" for device or group, and watt-hour pulse
- Initiator
- 24 Vdc input—BIM II
- 120 or 240 Vac input—BIMPS
- DIP switches for selecting an operating mode
- Three-contact connector with subnetwork
- Connector for PONI card for remote communications Local Display Units

Product Selection

Breaker Interface Module II (BIM II)



Breaker Interface Module

Description	Catalog Number
Breaker Interface Module	BIMII
	BIMPSII

Technical Data and Specifications

Power Requirement

- 15 VA maximum

Input Voltage

- 24 Vdc $\pm 5\%$ —BIM II
- 120 or 240 Vac $\pm 10\%$ —BIMPS

Operating Temperature

- 0°C to 70°C (32°C to 158°F)

Humidity

- 5% to 95% R.H. (noncondensing)

Alarm Contact Ratings

- 10A at 277 Vac (resistive)
- 10A at 30 Vdc (resistive)
- 1/3 hp at 125, 250 Vac

Dimensions

Approximate Dimensions in Inches (mm)

Connections and DIP Switch Rear Label Diagram

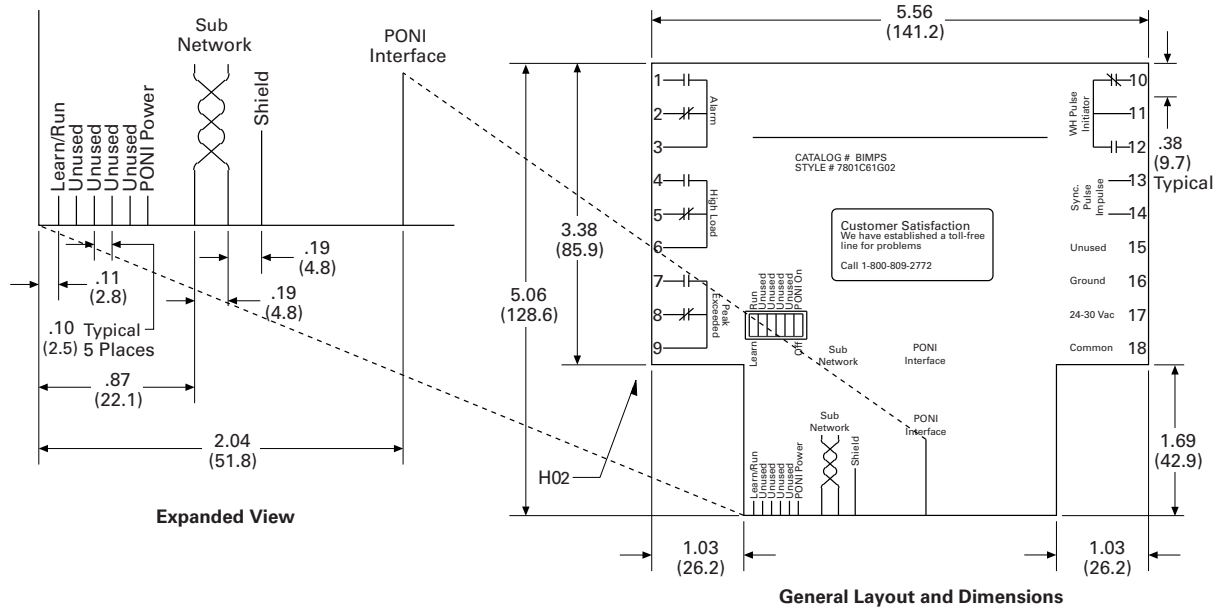

Breaker Interface Module

Height	Width	Depth
Without Communications Card		
6.72 (170.7)	10.25 (260.4)	2.60 (66.0)
With Communications Card		
6.72 (170.7)	10.25 (260.4)	3.85 (97.8)

Drilling Pattern

