

Phase Balance Protection

Phase balance protection relays continuously monitor a three phase AC power supply, tripping upon fault condition. These relays protect against asymmetrical under or over voltage.

The internal relay remains energised and the LED illuminates only when the voltage balance between all three phases is within the user adjustable limit and hence satisfactory for connection to the three phase equipment.

The unbalanced trip point is adjustable from 5% to 15% of the nominal voltage through the front control knob. The relay is self powered, requiring no auxiliary power supply, and is available with either a single or double pole changeover relay output and built-in 5 second time delay.



Models Available

B921 3 Phase 3 Wire

Product Features

- Protects against:-
Asymmetrical under and over voltage
- LED indication
- Single or double pole output available
- 5 second fixed time delay

For dimensions see page 3

For protection against asymmetrical under and over voltage

Connections

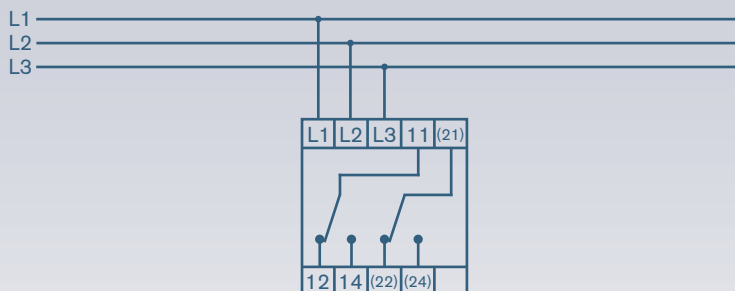

Ordering information

Code	Relay Type	Nominal Voltage	Output
B921	3 Phase 3 Wire	–	–
Specify	–	110, 380, 400, 415VL-L	–
Specify	–	50 to 600VL-L	–
1C/O	–	1 Pole Changeover Relay Output	–
2C/O	–	2 Pole Changeover Relay Output	–
Example	B921	415VL-L	2C/O

Specification

Nominal Voltage, U_n :

- 380, 400, 415VL-L
- 60-500V upon request

Calibrated Scale:

- 5 to 15% (adjustable)

Frequency:

- 50/60Hz (400Hz upon request)

Overload:

- $1.5 \times U_n$ continuous
- $2 \times U_n$ for 5 seconds

Burden:

- $< 2VA$

Time Delay:

- 5 second fixed time delay

Weight:

- 275g

General Specification

Reference Standards

Performance: IEC 144 / BS 5420 / VDE/VDI 0435 / IEC 947 / EN60947

Environmental

Calibration Temperature: 23°C

Operating Temperature: 0°C to 60°C

Storage Temperature: -10°C to 70°C

Temperature Coefficient: $\pm 0.03\%/^{\circ}\text{C}$

Relative Humidity: 0 - 95% non-condensing

Relay Output

Relay Type: Single pole change-over
(Except CST-100 has single pole normally open or normally closed)
(Double pole change-over available on some models as an option)

Contact Rating: 5A @ 250Vac (non-resistive), 1A @ 125Vdc (resistive)

Contact Life: 1,000,000 at 5A, 10,000,000 at 1A

Mechanical Life: 2,000,000 operations

Dielectric Strength: 4kV coil/contact, 1kV contact/contact

Optional Time Delay: 0.3-10 sec, 1-30 sec, 2-60 sec, 3-100 sec or 10-300 sec (delay on fault or reset)
(Note if the voltage supply to the protection relay falls below 75% of the nominal the timer will fail to operate and the relay will trip instantaneously upon fault)

Enclosure

Enclosure: Flame retardant black ABS plastic with screw type terminals

Enclosure Code: Case IP50, terminals IP10 to IEC529 and BS5490

Insulation Test: 2kV rms 50Hz 1min (to IEC 414) between Input / Case / AC Auxiliary

Mounting: 35mm DIN rail (DIN-EN 50022)

Markings: CE marked

Specification subject to change without notice.

Dimensions

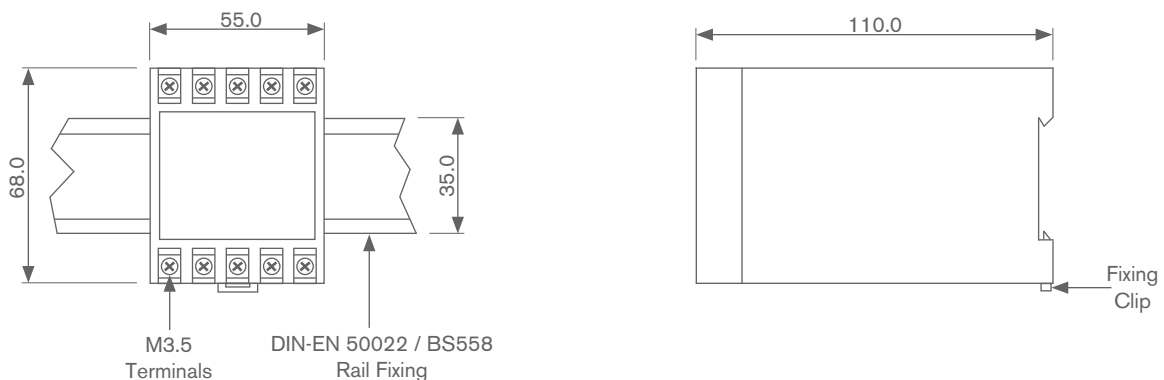

All dimensions in mm