

SPM91

DIN Rail Single Phase Energy Meter
Installation & Operation Manual V1.0



ZHUHAI PILOT TECHNOLOGY CO., LTD.



Danger and warning!

This device can be installed only by professionals.

The manufacturer shall not be held responsible for any accident caused by the failure to comply with the instructions in this manual.



Risks of electric shocks, burning, or explosion

- This device can be installed and maintained only by qualified people.
- Before operating the device, isolate the voltage input and power supply and short-circuit the secondary windings of all current transformers.
- Use appropriate voltage tester to make sure the voltage has been cut-off.
- Put all mechanical parts, doors, or covers in their original positions before energizing the device.
- Always supply the device with the correct working voltage during its operation.

Failure to take these preventive measures could cause damage to equipment or injuries to people.

CONTENTS

1. General Information.....	3
2. Features.....	3
3. Order Information	4
4. Figure and Installation Dimension	4
5. Wiring	5
6. Display and keys	6
6.1 Display instruction	6
6.2 Menu description	6
7. Main Technical Data	10
8. Communication Protocol	11

1. General Information

SPM91 DIN rail energy meter is a kind of new style single phase whole electronic type meter. The meter is completely conformed to the relative requirements of the International Standard IDT IEC 62053-21:2003 (Class 1). It is an integration of up-to-date micro-electronics technique, special large scale integrate circuit, advanced technique of digital sampling technique and SMT techniques etc.

SPM91 is used for measuring active energy power consumption in a rated frequency of 50Hz or 60Hz single phase alternating current circuit. It displays total energy consumption via LCD and is characterized with good reliability, compact size, light weight, specious nice appearance and easy installation.

2. Features

- ◆ 35mm DIN installing, in accordance with Standard DIN ED5002
- ◆ High accuracy, active energy accuracy up to class 1
- ◆ Measure and display V, I, P, kWh value
- ◆ 6+1 digits LCD display (999999.9 kWh)
- ◆ Passive pulse output, output signal is in accordance with Standard DIN43864
- ◆ LED indicates pulse

- ◆ Key-press for local parameter setting
- ◆ RS485 communication port, Modbus protocol

3. Order Information

SPM91 -- ① -- ②

Rated voltage	V1	220Vac direct, (or 230V, 240V)
	V2	120Vac direct, (or 110V)
Rated frequency	50	50Hz
	60	60Hz

4. Figure and Installation Dimension

SPM91 dimension: (Unit: mm)

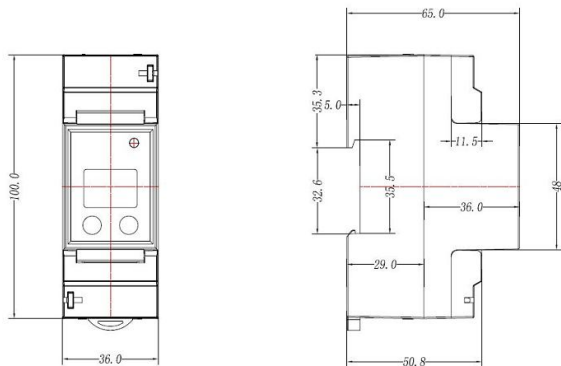

SPM91 installation

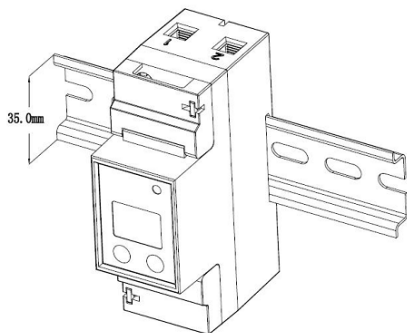

5. Wiring

SPM91 is direct connection type, (maximum rated current $\leq 63A$) Wiring as shown below:

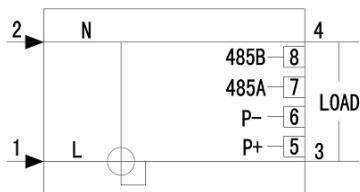

Pulse interface is passive, range of cut-in power: 5-30Vdc.

6. Display and keys

6.1 Display instruction

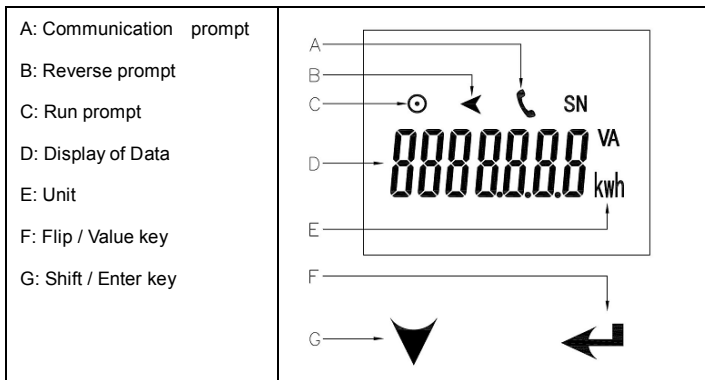

Device panel has an indicator light: PULSE.

It is indicator light for pulse output: For each pulse output, the indicator light flashes once, synchronous pulse output.

6.2 Menu description

6.2.1 The real-time data measure

After power on, short press flip key, users can cycle query active energy, voltage, current, active power.



6.2.2 Configuration data query

Under real-time data query interface, long press (> 3S) Enter key to enter the configuration data query interface, short press the flip button, users can cycle check:

- (1) prompt of version number (VEr) , version number,
- (2) baud rate prompt (bAU), and baud rate ,
- (3) prompt of addresses (Adr), and address.

Under this interface long press (>3S) the flip button, can back to the real-time data query interface.

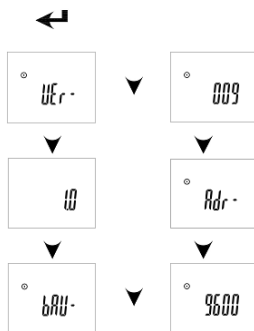

6.2.3 Configuration data modify

Under the configuration data query interface, long press (> 3S) Enter key to enter the configuration data modification interface, but entering the configuration data modification interface need to enter the correct password, the default password is "0000", if enter the wrong password ,the meter will prompt error, and automatically back to the configuration data query interface.



After entering the configuration data modification interface, short press the flip, can cycle query prompt of baud rate (bAU) , baud rate, prompt of address (Adr) , address, prompt of password (PSd) , password, clear energy prompt (CLr), clear energy command options.

Under this interface long press (>3S) the flip button, can back to the real-time data query interface.

Under this interface short press the Enter key, can enter the modification status, if the corresponding data bits flashing, it prompt that data can be modified.

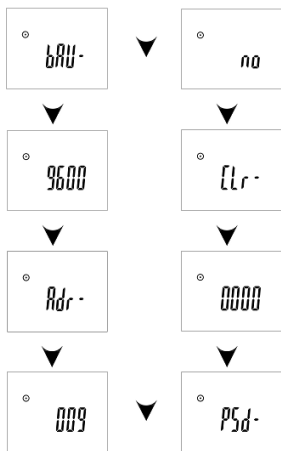

◆ Setting Example-1: Modify communication address

1. Long press (> 3S) Enter key to enter the configuration data modification interface, enter the correct password
2. Short press the flip key, enter the Adr menu.
3. Short press the Enter key, the address data starts flashing.
4. Under this interface short press the flip key for modifying data, short press the Enter key to shift.
5. After modifying the data to the desired address, press (> 3S) Enter button to save the address.
6. Complete address modification.

◆ Setting Example-2: Clear energy

1. Long press (> 3S) Enter key to enter the configuration data modification interface, enter the correct password
2. Short press the flip key, enter the CLr menu
3. Short press the Enter key, the remove command starts flashing, the default display (no) command
4. Under this interface short press the flip key for choosing (YES) or (no) command.
5. Select (YES) to clear energy, (no) does not clear, long press the Enter key (> 3S) to confirm
6. Automatically back to CLr menu.

7. Main Technical Data

Rated voltage	230Vac, direct
Rated (Max.) current	5(63)A direct
Input frequency	50Hz or 60Hz
Power supply	self-supply 230V, (184V-275V)
Starting current	0.4%Ib
Power consumption	<2W
Insulating property	Power frequency withstand voltage: AC 2 KV Impulse withstand voltage: 6KV
Accuracy	Class 1 (IEC62053-21)
Pulse output	1000imp/kWh

Communication	RS485 output, Modbus-RTU protocol Address: 1~247 Baudrate: 2400bps, 4800bps, 9600bps
Connection mode	1-phase 2-wire
Dimension	36 × 100 × 65mm
Installation mode	Standard 35mm DIN rail
Operating environment	Operating temperature: -20℃~+55℃ Storage temperature: -25℃~+70℃ Relative humidity: 5%~95%,non-condensing
Electrostatic discharge immunity test	IEC61000-4-2,Level 4
Radiated immunity test	IEC61000-4-3,Level 3
Electrical fast transient/ burst immunity test	IEC61000-4-4,Level 4
Surge immunity test (1,2/50μs~8/20μs)	IEC61000-4-5,Level 4
Conducted Emissions	EN55022, Class B
Radiated Emissions	EN55022, Class B

8. Communication Protocol

SPM91 support standard Modbus communication protocol, and support 0x03 and 0x10 command. Please refer to below registers list.

Because some data is too long, the device uses two registers to present. And these data is transits in way of “low byte in the former, high byte in the back”.

Register No.	Definition	Remarks
Real-time data registers(0x03 RO)		
40001	Active energy (low)	× 0.1, unit: kWh
40002	Active energy (high)	Low byte in the back, high byte in the former. Range: 0-999999.9
40003	Voltage	× 0.01, unit: V
40004	Current (low)	× 0.001, unit: A
40005	Current (high)	Low byte in the back, high byte in the former.
40006	Active power (low)	× 0.1, unit: W
40007	Active power (high)	The highest byte is the sign byte.
40008-40011	Reserved	
40012	Frequency	× 0.01, unit: Hz
Configuration parameter register (0x10 RW)		
40201	CT	Range:1-999
40202	Communication address	Range:1-247
40203	Baud rate	0:4800bps 1:9600bps others:2400bps
40207	Password	0x0000-0xFFFF
40251	Clear energy	Write 901 to clear energy

Notice:

- PILOT reserves the right to modify this manual without prior notice in view of continued improvement.
- Email: pilot166@pmac.com.cn

***Pilot* Zhuhai Pilot Technology Co., Ltd.**

Add: No. 15, Keji 6 Road, Chuangxin Hai'an, Tangjia High-tech Zone, Zhuhai,
Guangdong, 519085 China

Tel: +86 -756-3629687/ 3629688

Fax: +86-756-3629600/ 3629670

<http://www.pmac.com.cn>